

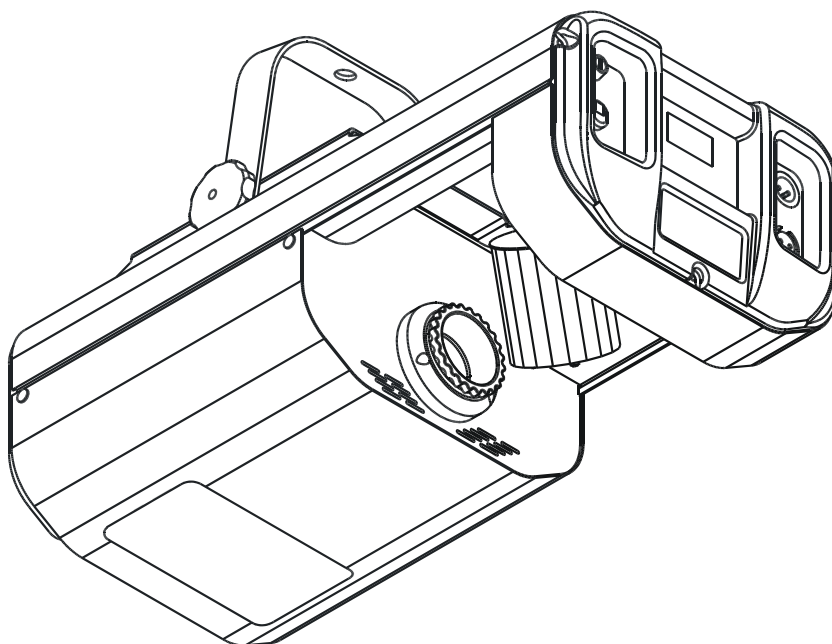

# ClubRoller 150<sup>GT</sup>



**ROBE.**

**USER MANUAL**

Version 1.3

# ClubRoller 150 CT

## Table of contents

<b>1. Safety instructions</b> .....	<b>3</b>
<b>2. Operating determinations</b> .....	<b>4</b>
<b>3. Description of the device</b> .....	<b>5</b>
<b>4. Installation</b> .....	<b>6</b>
4.1 Fitting/Exchanging the lamp .....	6
4.2 Rigging the fixture .....	7
4.3 Changing the power supply settings .....	9
4.4 Connection to the mains .....	10
4.5 DMX-512 connection/connection between fixtures .....	10
<b>5. ClubRoller 150 CT - DMX PROTOCOL, version 1.0</b> .....	<b>11</b>
<b>6. Controller mode</b> .....	<b>13</b>
6.1 DMX addressing.....	13
<b>7. Control menu map</b> .....	<b>14</b>
<b>8. Functions of the control panel</b> .....	<b>15</b>
8.1 Fixture Address .....	15
8.2 Microphone sensitivity .....	15
8.3 Demo-test sequences .....	15
8.4 Stand-alone setting .....	15
8.5 Fixture reset .....	16
8.6 Special functions .....	16
<b>9. Stand - alone mode</b> .....	<b>18</b>
<b>10. Error and information messages</b> .....	<b>19</b>
<b>11. Technical specifications</b> .....	<b>19</b>
<b>12. Maintenance and cleaning</b> .....	<b>21</b>

**CAUTION!**  
***Keep this device away from rain and moisture!***  
***Unplug mains lead before opening the housing!***

**FOR YOUR OWN SAFETY, PLEASE READ THIS USER MANUAL CAREFULLY  
BEFORE YOU INITIAL START - UP!**

## **1. Safety instructions**

Every person involved with installation and maintenance of this device have to:

- be qualified
- follow the instructions of this manual

**CAUTION!**  
***Be careful with your operations. With a high voltage you can suffer  
a dangerous electric shock when touching the wires!***

This device has left our premises in absolutely perfect condition. In order to maintain this condition and to ensure a safe operation, it is absolutely necessary for the user to follow the safety instructions and warning notes written in this manual.

### **Important:**

The manufacturer will not accept liability for any resulting damages caused by the non-observance of this manual or any unauthorized modification to the device.

Please consider that damages caused by manual modifications to the device are not subject to warranty.

Never let the power cord come into contact with other cables! Handle the power cord and all connections with the mains with particular caution!

Always plug in the power plug least. The power plug has to be accessible after installing the device.

Make sure that the power-cord is never crimped or damaged by sharp edges. Check the device and the power-cord from time to time.

Always disconnect from the mains, when the device is not in use or before cleaning it. Only handle the power cord by the plug. Never pull out the plug by tugging the power cord.

This device falls under protection class I. Therefore it is essential to connect the yellow/green conductor to earth.

The electric connection, repairs and servicing must be carried out by a qualified employee.  
Do not connect this device to a dimmer pack.

Do not switch the fixture on and off in short intervals as this would reduce the lamp's life.

During the initial start-up some smoke or smell may arise. This is a normal process and does not necessarily mean that the device is defective.

Do not touch the device's housing bare hands during its operation (housing becomes hot)!  
For replacement use lamps and fuses of same type and rating only.

**CAUTION ! EYEDAMAGES !**  
***Avoid looking directly into the light source  
(meant especially for epileptics)***

## 2. Operating determinations

This device was designed for indoor use only.

If the device has been exposed to drastic temperature fluctuation (e.g. after transportation), do not switch it on immediately. The arising condensation water might damage your device. Leave the device switched off until it has reached room temperature.

When taking the device into operation, please make sure that the housing is closed firmly with all the necessary screws tightened up.

Never run the device without lamp!

Do not shake the device. Avoid brute force when installing or operating the device.

When choosing the installation-spot, please make sure that the device is not exposed to extreme heat, moisture or dust. There should not be any cables lying around. You endanger your own and the safety of others!

The symbol  determines the minimum distance from lighted objects. The minimum distance between light-output and the illuminated surface must be more than 0.8 meter.

Make sure that the area below the installation place is blocked when rigging, derigging or servicing the fixture.

Always fix the fixture with an appropriate safety-rope. Fix the safety-rope at the correct holes only.

Only operate the fixture after having checked that the housing is firmly closed and all screws are tightly fastened.

The lamp must never be ignited if the objective-lens or any housing-cover is open, as discharge lamps may explode and emit a high ultraviolet radiation, which may cause burns.

The maximum ambient temperature 45° C must never be exceeded. Otherwise, the lamp is switched off and the fixture is out of operation for 5 minutes.

**CAUTION!**  
***The lens has to be replaced when it is obviously damaged,  
so that its function is impaired, e. g. due to cracks or deep scratches!***

Operate the device only after having familiarized with its functions. Do not permit operation by persons not qualified for operating the device. Most damages are the result of unprofessional operation!

**CAUTION!**  
***The lamp has to be replaced when it is damaged  
or deformed due to the heat!***

Wait at least 15 minutes before removing the lamp.

Please use the original packaging if the device is to be transported.

Please consider that unauthorized modifications on the device are forbidden due to safety reasons!

If this device will be operated in any way different to the one described in this manual, the product may suffer damages and the guarantee becomes void. Furthermore, any other operation may lead to dangers like short-circuit, burns, electric shock, burns due to ultraviolet radiation, lamp explosion, crash etc.

### 3. Description of the device

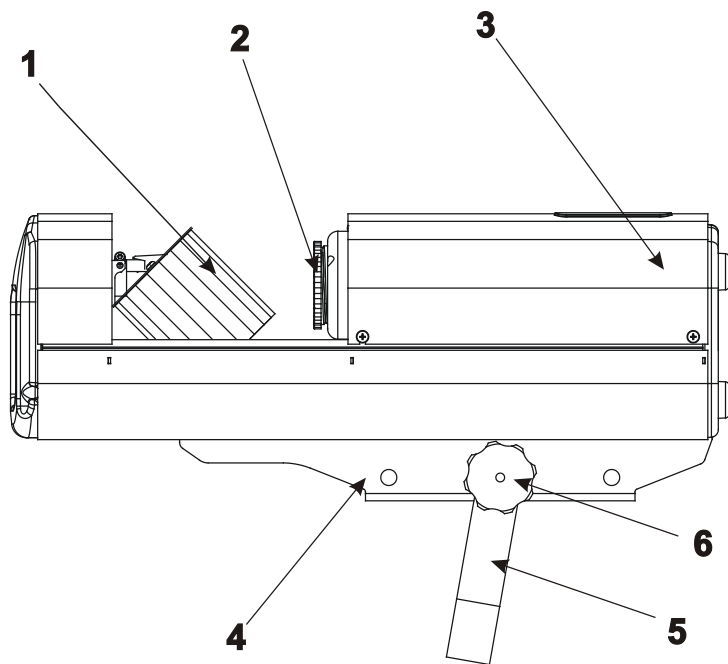

- 1 - Drum
- 2 - Objective
- 3 - Top cover
- 4 - Mounting base
- 5 - Mounting bracket
- 6 - Bracket screw

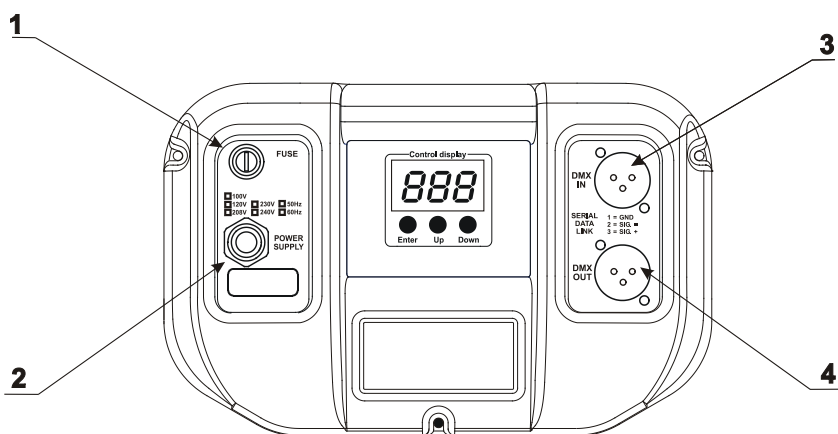

#### Front panel:

- 1 - Fuseholder
- 2 - Powercord
- 3 - DMX input
- 4 - DMX output

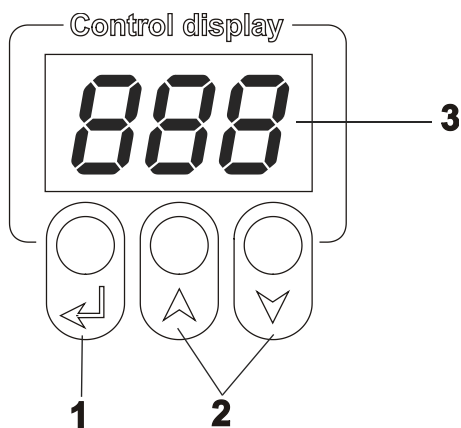

#### Control board:

- 1 - Enter-button
- 2 - Up,Down buttons
- 3 - Display

## 4. Installation

### 4.1 Fitting/Exchanging the lamp

**DANGER !**  
**Install the lamps with the device switched off only.**  
**Unplug from mains before !**

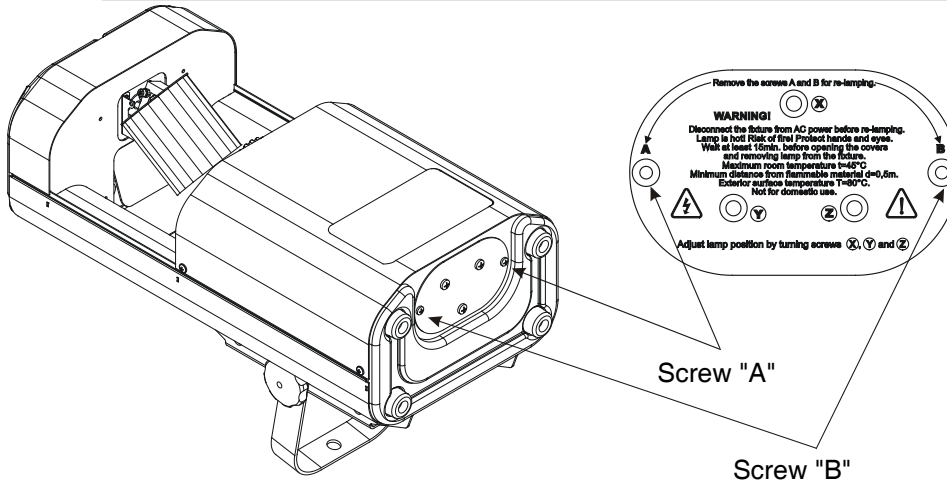

To insert the lamp open the small cover at the rear panel (see the drawing) by loosening the 2 screws marked "A" and "B" on the cover.

Gently pull out the lamp assembly.

If changing the lamp, remove the old lamp from the socket. Insert the lamp to the socket.

Do not install a lamp with a higher wattage! A lamp like this generates temperatures the device is not designed for.

Damages caused by non-observance are not subject to warranty. Please follow the lamp manufacturer's notes!

Do not touch the glass-bulb bare hands during the installation! Make sure that the lamp is installed tightly into the lampholder system.

Reinsert the lamp assembly and tighten the 2 screws again.

**Do not operate this fixture with opened housing-cover!**

### Lamp adjustment

The lampholder is aligned at the factory. Due to differences between lamps, fine adjustment may improve light performance.

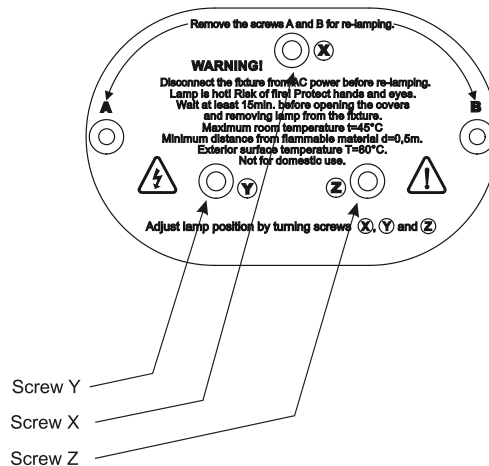

Strike the lamp and focus the light on a flat surface (wall). Center the hot-spot (the brightest part of the beam) using the 3 adjustment screws "X, Y, Z". Turn one screw at a time to drag the hot-spot diagonally across the projected image. If you cannot detect a hot-spot, adjust the lamp until the light is even.

To reduce a hot-spot, pull the lamp in by turning all three screws "X, Y, Z" clockwise ¼-turn at a time until the light is evenly distributed.

If the light is brighter around the edge than it is in the center, or if light output is low, the lamp is too far back in the reflector. „Push” the lamp out by turning the screws "X,Y,Z" counterclockwise ¼-turn at a time the light is bright and evenly distributed.

## 4.2 Rigging the fixture

The installation of the projector has to be built and constructed in a way that it can hold 10 times the weight for 1 hour without any harming deformation.

The installation must always be secured with a secondary safety attachment, e.g. an appropriate catch net. This secondary safety attachment must be constructed in a way that no part of the installation can fall down if the main attachment fails.

When rigging, derigging or servicing the fixture staying in the area below the installation place, on bridges, under high working places and other endangered areas is forbidden.

The operator has to make sure that safety-relating and machine-technical installations are approved by an expert before taking into operation for the first time and after changes before taking into operation another time.

The operator has to make sure that safety-relating and machine-technical installations are approved by an expert after every four year in the course of an acceptance test.

The operator has to make sure that safety-relating and machine-technical installations are approved by a skilled person once a year.

The projector should be installed outside areas where persons may walk by or be seated.

Important! Overhead rigging requires extensive experience, including calculating working load limits, installation material being used, and periodic safety inspection of all installation material and the projector. If you lack these qualifications, do not attempt the installation yourself, but instead use a professional structural rigger. Improper installation can result in bodily injury and/or damage to property.

The projector has to be installed out of the reach of people.

If the projector shall be lowered from the ceiling or high joists, professional trussing systems have to be used. The projector must never be fixed swinging freely in the room.

**Caution:** Projectors may cause severe injuries when crashing down! If you have doubts concerning the safety of a possible installation, do not install the projector!

Before rigging make sure that the installation area can hold a minimum point load of 10 times the projector's weight.

***Danger of fire !  
When installing the device, make sure there is no highly-inflammable  
material (decoration articles, etc.) within a distance of min. 0.5 m.***

### 1. Mounting via mounting holes.

Remove the ClubRoller's bracket by unscrewing the 2 bracket screws.

Mount the clamp (not included) to one of the two mounting holes in the mounting base. This mounting holes have a diameter of 12 mm. Fix the ClubRoller via the clamp on the truss and tighten the rigging clamp.

For overhead use always install a safety rope that can hold at least 10 times the weight of the fixture. You must only use safety rope with screw-on carabine. Pull the safety rope through the mounting base and over the trussing system etc. Insert the end in the carabine and tighten the fixation screw.

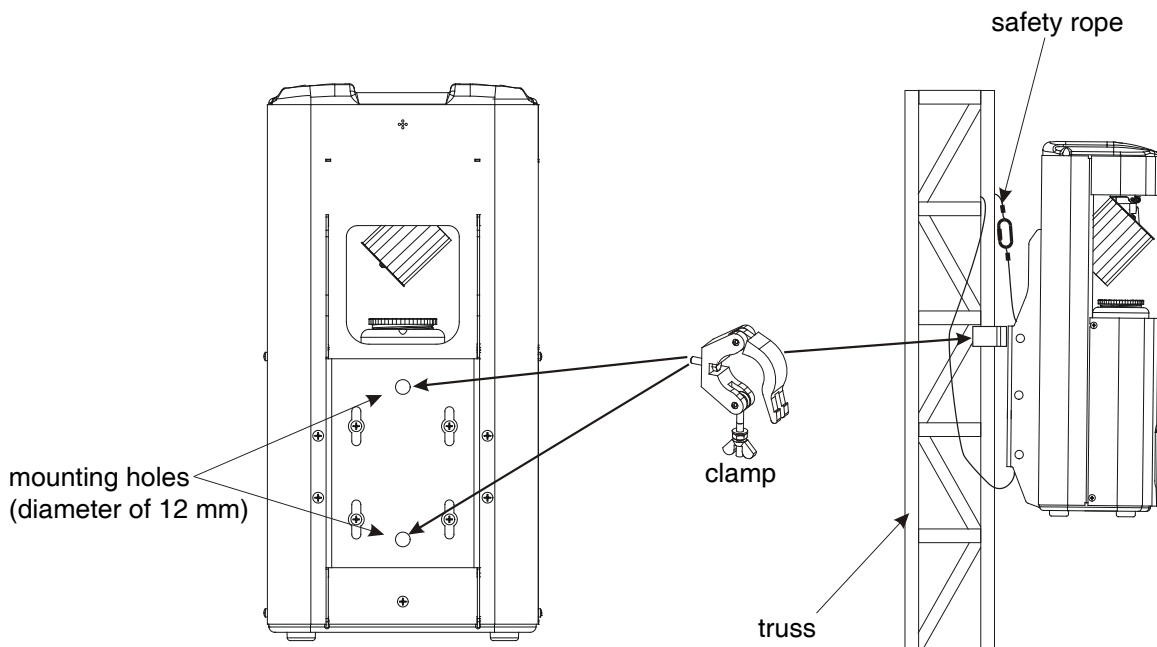

## 2. Mounting via a mounting plate.

Mount the mounting plate (it is not standard part of delivery) on the wall using appropriate screws. The 4 mounting holes in the mounting plate have a diameter of 8 mm. Put the ClubRoller on the mounting plate and secure it with the 2 bracket screws.

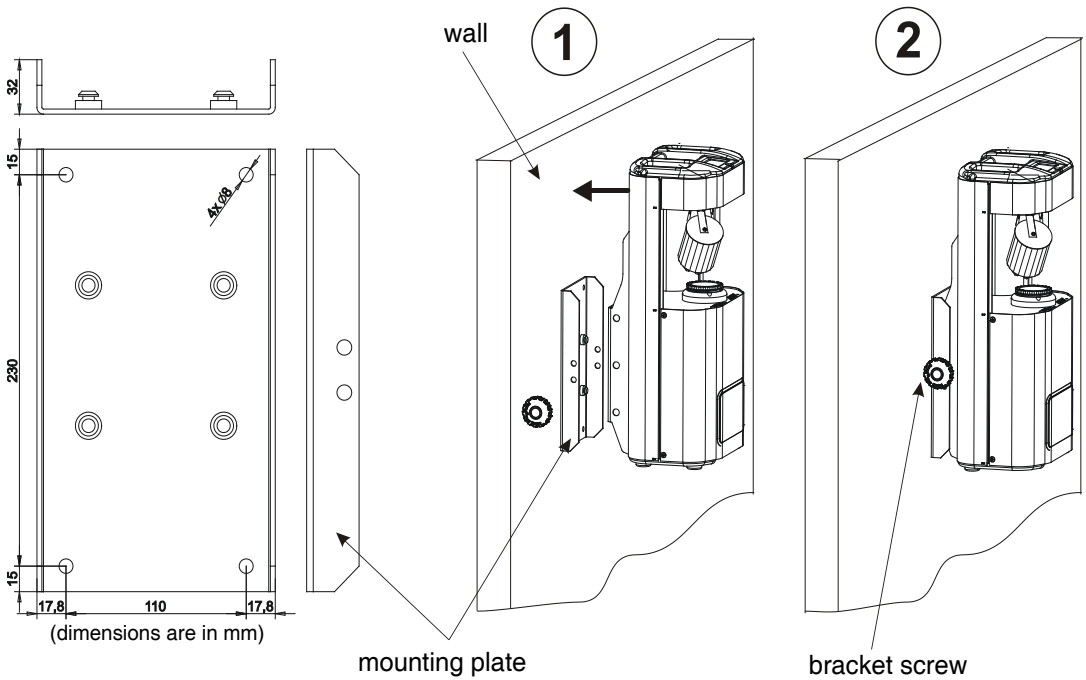

## 3. Mounting via a mounting bracket.

Fix the roller's bracket and tilt-fixation plate along the picture below.

Mount the clamp (not included) to the mounting bracket. The hole in the bracket has a diameter of 12 mm. Fix the roller via the clamp on a truss and adjust desired angle using tilt-lock screw. Retighten this screw.

For overhead use always install a safety rope that can hold at least 10 times the weight of the fixture. You must only use safety rope with screw-on carabine. Pull the safety rope through the mounting base and over the trussing system etc.

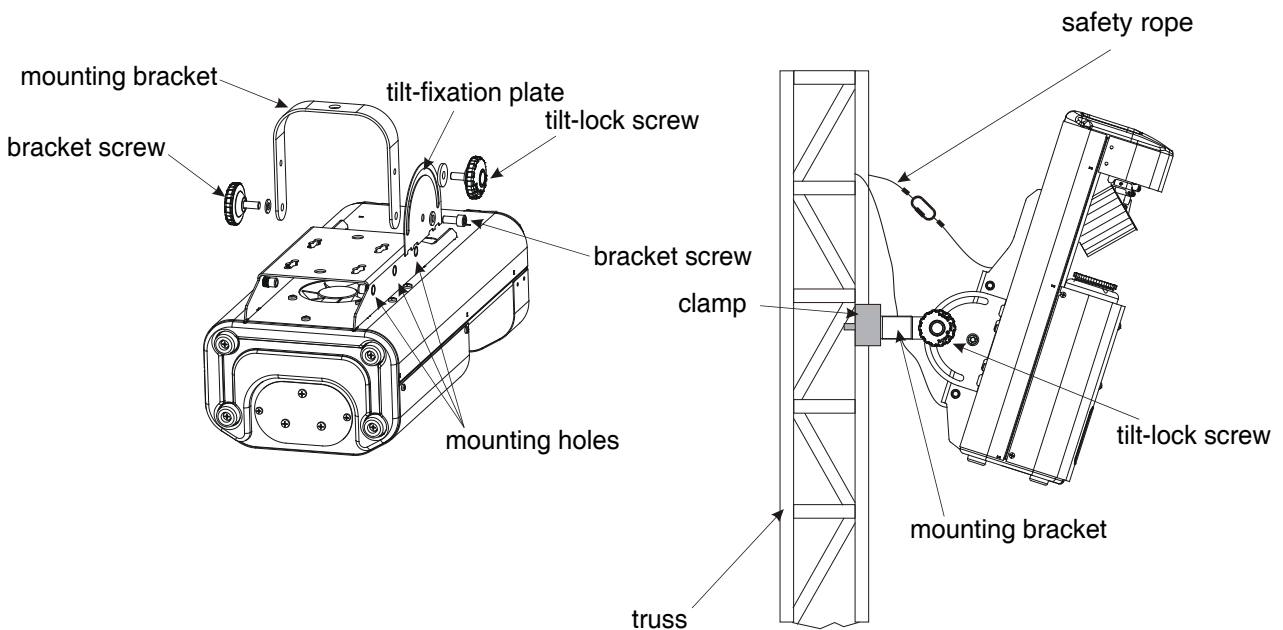



### 4.3 Changing the power supply settings

Both the transformer and the ballast must be connected correctly for the local AC voltage and frequency. The wrong settings can cause poor performance or damage of the fixture. The factory settings are printed next to the power cord on the front panel.

If you want to change the power supply settings, follow the instructions:

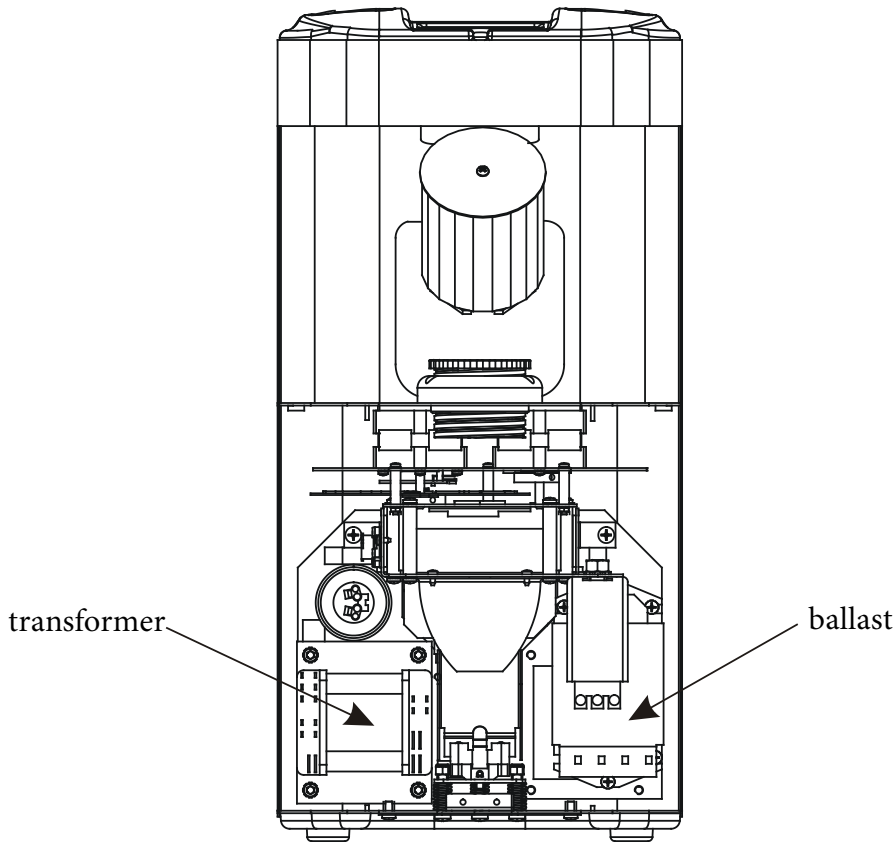

#### EU version:

1. Disconnect the fixture from AC power.
2. Remove the top cover of the fixture by loosening the 4 screws.
3. Move the wire **1** on the transformer connection block to the position according to the desired voltage.
4. Move the wire **2** on the ballast connection block to the position according to the desired frequency/voltage.

#### US version:

1. Disconnect the fixture from AC power.
2. Remove the front cover by loosening the 4 screws.
3. Move the wire **1** on the transformer connection block to the position according to the desired voltage.
4. Move the wire **2** on the ballast connection block to the position according to the desired frequency.

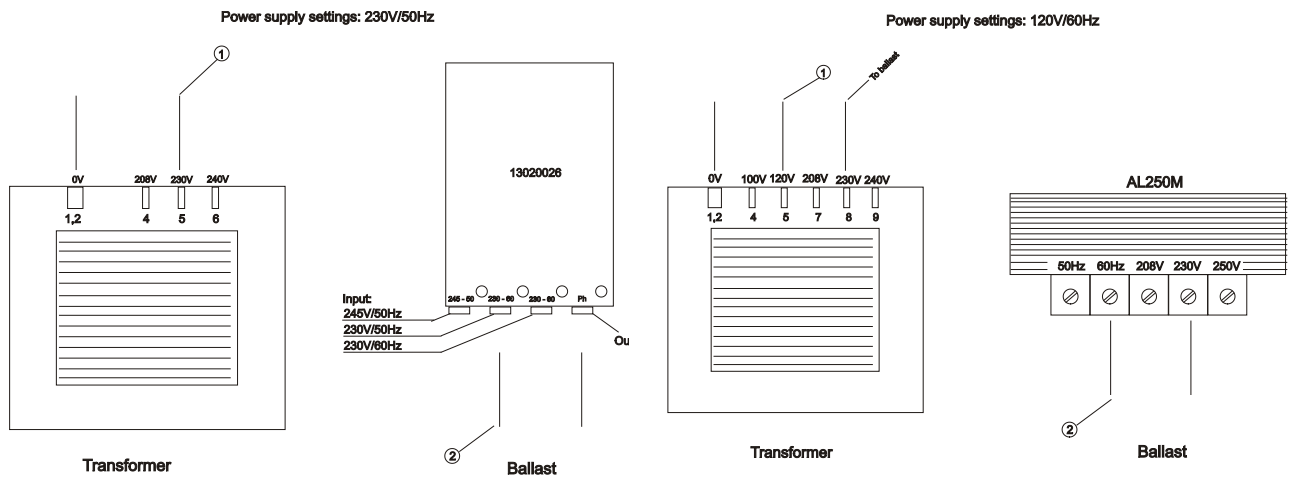

## 4.4 Connection to the mains

The earth has to be connected!  
Connect the fixture to the mains with the enclosed power plug.

The occupation of the connection-cables is as follows:

Cable (EU)	Cable (US)	Pin	International
Brown	Black	Live	L
Light blue	White	Neutral	N
Yellow/Green	Green	Earth	

## 4.5 DMX-512 connection/connection between fixtures

The fixture is equipped with 3-pin XLR sockets for DMX input and output. Only use a shielded twisted-pair cable designed for RS-485 and 3-pin XLR-plugs and connectors in order to connect the controller with the fixture or one fixture with another.

Occupation of the XLR-connection:

**DMX - output**  
XLR mounting-socket:



**DMX-input**  
XLR mounting-plug:

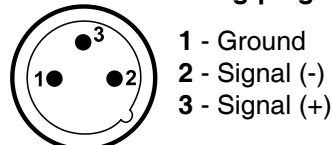

If you are using standard controllers, you can connect the DMX-output of the controller directly with the DMX-input of the first fixture in the DMX-chain. If you wish to connect DMX-controllers with other XLR-outputs, you need to use adapter-cables.

### Building a serial DMX-chain:

Connect the DMX-output of the first fixture in the DMX-chain with the DMX-input of the next fixture. Always connect one output with the input of the next fixture until all fixtures are connected.

**Caution:** At the last fixture, the DMX-cable has to be terminated with a terminator. Solder a 120 Ohm resistor between Signal (-) and Signal (+) into a 3-pin XLR-plug and plug it in the DMX-output of the last fixture.

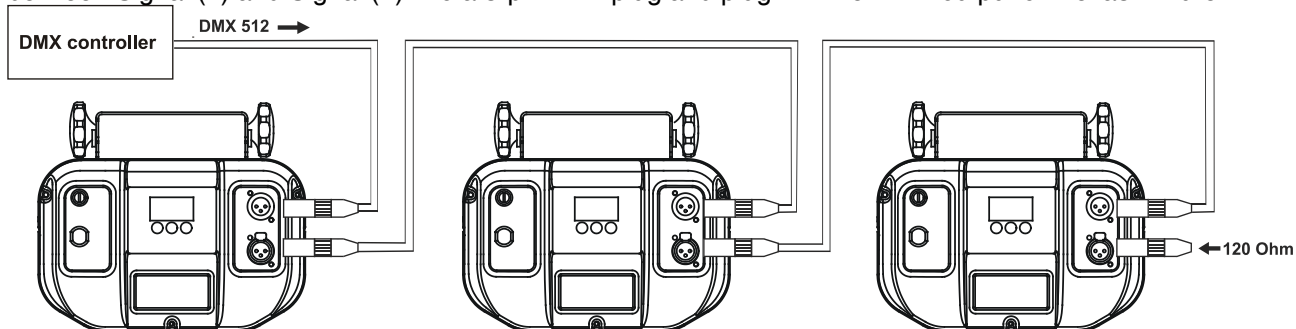

### Building a master/slave-chain:

Connect the DMX-output of the master fixture in the data-chain with the DMX-input of the first slave. Always connect output with the input of the next slave until all slaves are connected (up to 9 fixtures).

**Caution:** It's necessary to insert the XLR termination plug (with 120 Ohm) into the input of the master fixture and into the output of the last slave fixture in the link in order to ensure proper transmission on the data link.

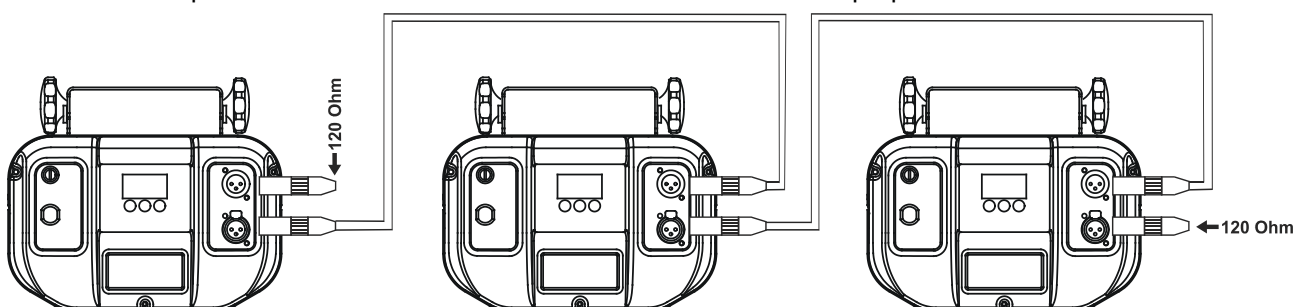



4	112-117	Gobo 8	proportional
	118-123	Gobo 9	proportional
	124-129	Gobo 10	proportional
	130-135	Gobo 11	proportional
	136-141	Gobo 12	proportional
	142-147	Gobo 13	proportional
	148-153	Open/hole <i>Pulse movement between two gobos ,from slow to fast</i>	proportional
	154-157	Hole --> blackout	proportional
	158-161	blackout --> Gobo 1	proportional
	162-165	Gobo 1 --> Gobo 2	proportional
	166-169	Gobo 2 --> Gobo 3	proportional
	170-173	Gobo 3 --> Gobo 4	proportional
	174-177	Gobo 4 --> Gobo 5	proportional
	178-181	Gobo 5 --> Gobo 6	proportional
	182-185	Gobo 6 --> Gobo 7	proportional
	186-189	Gobo 7 --> Gobo 8	proportional
	190-193	Gobo 8 --> Gobo 9	proportional
	194-197	Gobo 9 --> Gobo 10	proportional
	198-201	Gobo 10 --> Gobo 11	proportional
	202-205	Gobo 11 --> Gobo 12	proportional
	206-209	Gobo 12 --> Gobo 13	proportional
210-213	Gobo 13 --> blackout	proportional	
214-217	blackout --> hole	proportional	
218-229	Gobo wheel rotation from fast to slow (forward)	proportional	
230-231	No rotation	step	
232-243	Gobo wheel rotation from slow to fast (backward )	proportional	
244-249	Random gobo selection by audio control	step	
250-255	Auto random gobo selection from fast to slow	proportional	
5		<b>No function</b>	
6	0-5	<b>Shutter,stroke,program trigger</b> Closed	step
	6-95	Open	step
	96-127	Strobe-effect from slow to fast	proportional
	128-139	Reset	step
	140-191	Program time trigger (editable program runs by time control)	step
	192-223	Program audio trigger (editable program runs by audio control)	step
	224-255	Random Audio trigger (random effects run by audio control)	step

## 6. Controller mode

The fixtures are individually addressed on a data link and connected to the controller. The fixtures respond to the DMX signal from the controller.

### 6.1 DMX addressing

The control panel on the front panel of the fixture allows you to assign the DMX fixture address, which is defined as the first channel from which the ClubRoller 150 will respond to the controller.

If you set, for example, the address to channel 7, the ClubRoller 150 will use the channels 7 to 12 for control. Please, be sure that you don't have any overlapping channels in order to control each ClubRoller 150 correctly and independently from any other fixture on the DMX data link.

If two, three or more ClubRoller 150 are addressed similarly, they will work similarly.

For address setting, please refer to the instructions under "Fixture address" (menu "001").

**Note:** After switching on, the ClubRoller 150 will automatically detect whether DMX 512 data is received or not. If there is no data received at the DMX-input, the display will start to flash "001" with actually set address.

This situation can occur if:

- the 3 PIN XLR plug (cable with DMX signal from controller) is not connected with the input of the ClubRoller 150
- the controller is switched off or defective, the cable or connector is defective or the signal wires are swapped in the input connector.

**Note:** It's necessary to insert the XLR termination plug (with 120 Ohm) to the last fixture in the link in order to ensure proper transmission on the DMX data link.

## 7.Control menu map

Default settings=**Bold print**

**001** (001-507)

**MI.S.** (01..10..20)

**tSt**

**St.A.**

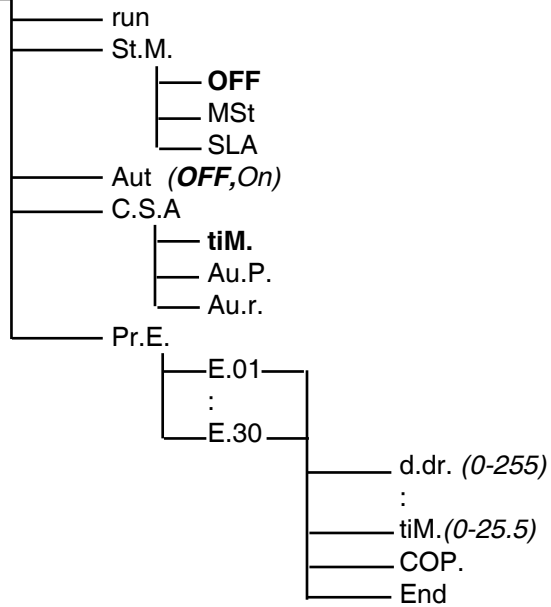

**SPE.**

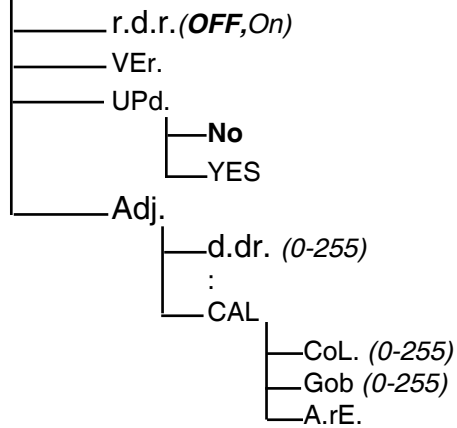

**rES.**

## 8. Functions of the control panel

The control panel situated on the front cover of the ClubRoller offers several features. You can simply set the DMX address or master (slave) mode, switch On and Off the lamp, run a test, make a reset and also use other functions for setting fixture behaviour.

### Control elements on the control board:

↵ [ENTER] button- enters menu, confirms adjusted values and leaves menu.

▲ , ▼ [UP] button and [DOWN] button- moves between menu items on the the same level, sets values.

In order to leave the menu without saving value, press [UP] and [DOWN ] at the same time.

After switching the fixture on, the display shows the initial DMX address:

Use [UP],[DOWN] to browse through the menu. To select a function or submenu, press [ENTER].

### 8.1 Fixture Address

Use this menu to set the DMX address of the fixture which is defined as the first channel from which the fixture will respond to the controller.

#### For address setting follow this procedure:

1. Switch On the fixture and wait until the fixture reset has finished ("rES" is flashing on the display).
2. Browse through the menu by pressing the [UP] and [DOWN] keys until the display shows current address "001". Confirm by pressing [ENTER] key and "001" will start to flash frequently.
3. Use the [UP] and [Down] keys to select the desired address.
4. Confirm by pressing [ENTER].

After having addressed fixtures, you may now start operating fixtures via your lighting controller.

### 8.2 Microphone sensitivity

Select this function to adjust the microphone sensitivity from 1 (maximum) to 20 (minimum).

### 8.3 Demo-test sequences

Use the item to run a built-in demo-test sequences without an external controller, which will show you some possibilities of using the fixture.

### 8.4 Stand-alone setting

Select this menu to set fixture behaviour in stand-alone mode.

**r.Pr.** --- **Running program.** Select this menu to run a program in a loop.

**St.M.** --- **Stand-alone mode.** This function allows you to set the fixture as master or as slave:

**OFF.** --- The option disables Master/slave operation.

**Mst** --- **Master.** This function sets the fixture as a master.

**SLA** --- **Slave.** This function sets the fixture as a slave.

**Aut.** --- **Automatically playback.** This function allows you to play the program automatically after switching the fixture on. The program will be played continuously in a loop.

**C.S.A.** --- **Control of the stand-alone operation.**

**tim.** --- **Time trigger.** Select this item to run program by time control.

**Au.P.** --- **Audio trigger program.**Select this item to run program by audio control

**Au.r.** --- **Audio/auto trigger random effect.**Select this item to run random generated effects by the audio control.If there are no audio impulses present,the fixture will generate random effects.

**Pr.E.** --- **Editing program.**Select this menu to edit the program.The fixture has one editable program.Each prog. step has a step time-the time,during which effects last in the current step.

Programming procedure:

1. Press [UP] or [DOWN] to select the desired program step ("E.01" - "E.30") and press [ENTER].
2. Press [UP] or [DOWN] to select the desired item and press [ENTER]-button.Now you can edit by [UP] or [DOWN] buttons the DMX value (0-255) for selected item:

**d.dr.** - declination of the drum,value 0-255

**ro.d.** - rotation of the drum,value 0-255

**Col.** - colour wheel,value 0-255

**Gob.** - gobo wheel, value 0-255

**COPY** - copying the current prog. step to the next prog. step.

**tim.** - step time,value 0-25.5 seconds

**End.** - this item stops the program.

Press [ENTER]-button to confirm adjusted value .

- 3.Select next prog. step and repeat this procedure (steps 1-3).

The number of steps in your program will be determined by the position in which you confirm the "End" for the end of the program.If you want to extend the program, select "COP." in the last step to copy current step to the next step.

## 8.5 Fixture reset



Select this item if you wish to make a fixture reset.

## 8.6 Special functions



Use this menu for special services like updating software or effect calibration.

**r.d.r.** --- **Reverse drum rotation** - This function allows you to invert the drum rotation. Use the [ Up ] and [Down ] keys to select "On" if you wish this feature or "Off" if you don't wish this feature and press [ Enter ] to confirm and return to the main menu.

**VEr.** --- **Software version.**Select this function to read the software version of the fixture processor.

**UPd.** --- **Software update** - Using this function you can update software in the fixture via PC and serial link.

The following are required in order to update software:

- PC running Windows 95/98/2000/XP or Linux
- DMX Software Uploader
- Flash cable RS232/DMX (No.13050624)

**Note1:**Software update should execute a qualified person.If you lack qualification, do not attempt the update yourself and ask for help your ROBE distributor.

**Note 2:**DMX address,program and all settings will be set to their default values.

### To update software in the fixture:

- 1.Installation of DMX Software Uploader:

1.DMX Software Uploader program is available from the ROBE web site at [WWW.robe.cz](http://WWW.robe.cz).

2.Make a new directory ( e.g. Robe\_Uploader) on your hard disk and download the software to it.

3.Unpack the program from the archive. Program file has name:DSU\_name of corresponding fixture\_SoftwareID.If the Robe fixture is produced in magnetic and electronic ballast version, the name of DMX Software Uploader is the same for both versions.

SoftwareID describes the versions of fixture software included in DMX Software Uploader. Higher number means later software versions.

- 2.Fixture software updating:



1. Determine which of your COM port is available on your PC and connect it with to the DMX input of the fixture using the Flash cable. Do not extend this cable! Disconnect the fixture from the other fixtures in DMX chain! Turn on the computer and the fixture.

2. Switch the fixture to the update mode by selecting the option Software update in menu Special Functions on the fixture control panel: SPE-->UPd-->yES. (From this option you cannot return back to the main menu. If you do not want to continue in software update, you have to switch off and on the fixture to leave this option!)

3. It is recommended that you exit all programs before running the Software Uploader.

4. Start the Software Uploader program. Select desired COM and then click Connect button.

If the connection is OK, click Start Uploading button to start uploading. It will take several minutes to perform software update. If the option "Incremental Update" isn't checked, all processors will be updated (including processors with the same software version).

If you wish to update only later versions of processors, enable the Incremental Update check box. Avoid interrupting the process. Update status is being displayed in the list window.

When the update is finished, the line with the text "The fixture is successfully updated" will appear in this window and the fixture will reset with the new software.

Note: In the case of interruption of the upload process (e.g. power cut), the fixture remains in the update mode and you have to repeat the software update again.

For example: The fixture was switched off before finishing software upload. After switching the fixture on again, the fixture is still in the update mode and the display is dark. Restart the Software Uploader program and repeat software update from your PC.

**CAL. --- Effect calibration.** By this function you can calibrate and adjust the effects to their standard/right positions. Disconnect the DMX controller from the fixture and select "**AdJ.**" menu. The display shows step by step effects by which you can adjust the fixture to the required position before the function calibration (DMX controller must be disconnected). When the positioning is finished, select "**CAL.**" and press [ENTER]:

#### 1. Calibration via the control board

Disconnect DMX controller from the fixture. Press [ENTER] to display the following items: "**Col.,Gob.**" for very smooth function calibration. Select one of them and press [ENTER] and use the [UP] and [DOWN] in order to adjust their right value from 0 to 255. Then press [ENTER] to confirm. After having calibrated all effect wheels use the "**A.rE.**" function in order to write the calibration value to the memory (EEPROM) and to make a reset.

#### 2. Calibration via the external controller

Connect the DMX controller to the fixture, press [ENTER] to display the following items: "**Col,Gob**". Select one of them and press [ENTER] and now you can calibrate this effect by your controller. The DMX calibration protocol is described below:

Effect	Channel
"Col."- Colour wheel	7
"Gob."- Gobo wheel	8

After having calibrated all effect wheels use the "**A.rE.**" function in order to write the calibration value to the memory (EEPROM) and to make a reset.

## 9. Stand - alone mode

The fixtures on a data link are not connected to the controller but can execute pre-set program which can be different for every fixture. "Stand-alone operation" can be applied to the single fixture (the fixture may be set to the master or slave mode ) or to multiple fixtures operating synchronously. Effect actions are triggered by sound, using built-in microphone, or automatically using an internal timer.

Synchronous operation of multiple fixtures requires that they must be connected on a data link and one of them is set as a master ("MSt") and the rest as the slaves ("SLA"). Up to 32 fixtures can be connected in master/slave chain. Only one fixture can be set as the master. The slaves mimic the behavior of the master.

**Important!:** Disconnect the fixtures from the DMX controller before master/slave operating , otherwise data collisions can occur and the fixtures will not work properly!

### Time control:

The master fixture starts simultaneous program start in the other slave fixtures. All fixtures have a definite, synchronized starting point when playing back their programs. Every fixture runs its program repeatedly , starting the program step No.1 when requested by the master .

For example:

If the slave fixture has a shorter program length, it will continuously repeat its program until the master fixture finishes its own program and restarts its program running (slave 1- prog.step 3 will not be finished).

If the slave fixture has a longer program length, it will restart at prog. step 1 before it completes all its prog.steps

(slave 2 - prog.step 5 will not be played)- see the picture bellow.

**Diagram 1**

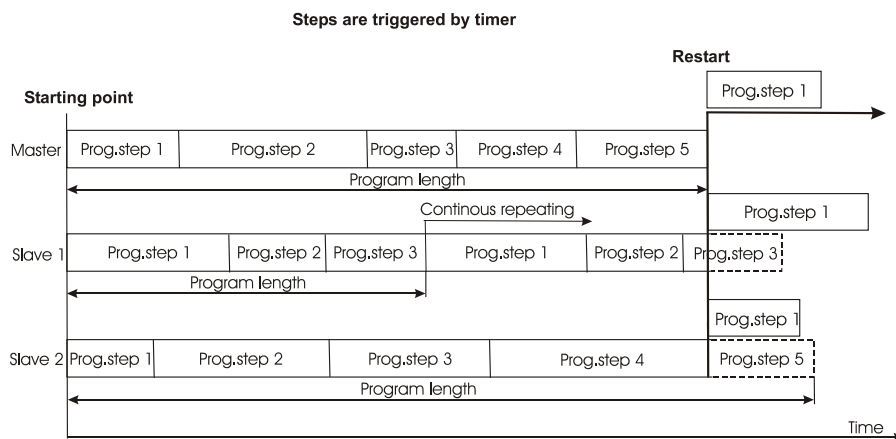

### Audio control:

The sound beat starts program steps simultaneous in the master fixture and in the slave fixtures. Every fixture runs its program repeatedly , starting the program step when requested by the master. (Master is controlled by sound and sends demand on the slaves to move them to the next prog.step).

**Diagram 2**

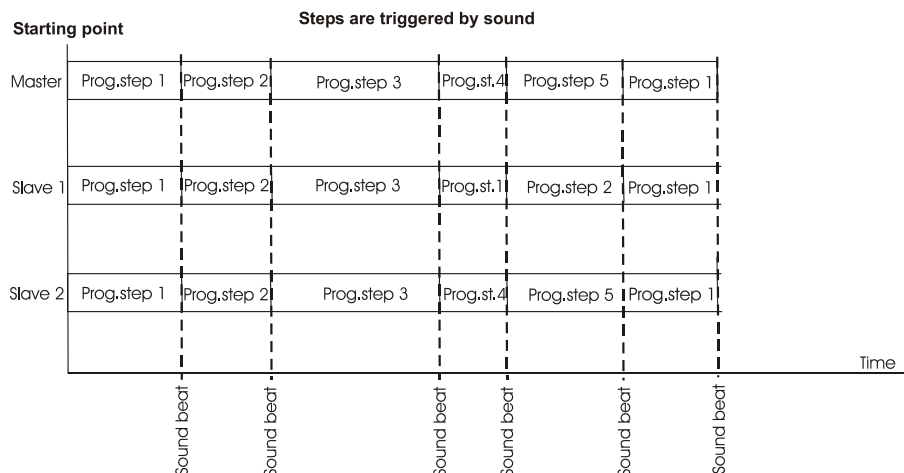

### Operating multiple fixtures in stand-alone mode.

1. Select one fixture and set it as a master (Menu path: "St.A."---->"St.M."---->MSt).
2. The rest of the fixtures set as slaves (Menu path: "St.A."---->"St.M."---->SLA).
3. Build the master/slave chain. (See chapter DMX-512 connection and Master/Slave connection).
4. Activate automatically program running after switching the fixtures on (Menu path: "St.A."---->"Aut."---->On).
5. Set the program running options (Menu path: "St.A."---->"C.S.A.") on the master and slaves:

For time control of the fixtures select item "tim" on the master and all slaves.  
 For audio control of the fixtures select item "Au.P." on the master and all slaves.  
 For audio random selection of effects ,select item "Au.r" on the master and all slaves

**Note: Master-slave operation is only possible among fixtures: ClubScan 150,ClubScan 250,Fusion, Funky,ClubRoller 150,ClubRoller 250.**

## 10. Error and information messages

### **C.Er.** (color-wheel error)

This message will appear after the reset of the fixture if the magnetic-indexing circuit malfunctions (sensor failed or magnet missing) or the stepping-motor is defective (or its driver circuit on the main PCB). The color-wheel is not located in the default position after the reset.

### **G.Er.** (static gobo-wheel error)

This message will appear after the reset of the fixture if the magnetic-indexing circuit malfunctions (sensor failed or magnet missing) or the stepping-motor is defective (or its driver circuit on the main PCB). The static gobo-wheel is not located in the default position after the reset.

### **M.Er.**(Master error)

The message informs you that the fixture was addressed as a master and DMX signal is connected to its input.Disconnect the DMX controller from fixture's input and make a reset.

## 11. Technical specifications

### **Power supply:**

EU version      -Voltage.....208,230,240 V AC, 50/60Hz ~  
                       -Fuse.....T 2,5 A@ 230V  
 US version      -Voltage.....100,120,208,230,240 V AC, 50/60Hz ~  
                       -Fuse.....T 5 A@ 120V  
                       -Power consumption.....220VA

### **Lamp:**

Osram HSD 150/70 ,G12

### **Optical System:**

- High reflecting aluminium-coated parabolic reflector
- Manual focus
- 19° beam angle

### **Beampath:**

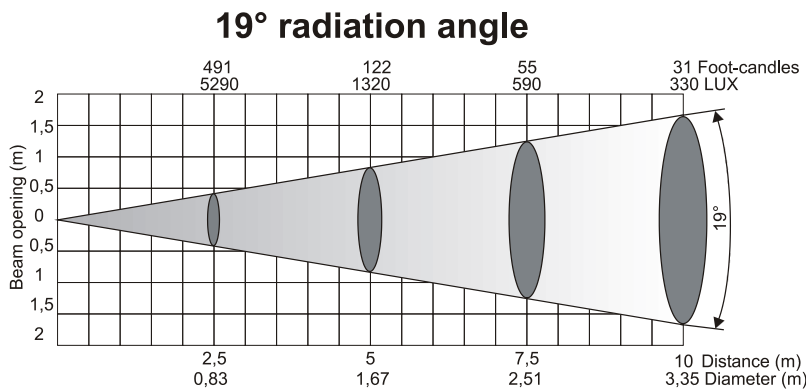

**Colours:**

- 11 dichroic-filters plus white
- UV-filter
- 3 dichroic semicolours filters
- Colour-wheel with variable rotation speed

**Static gobos:**

- 13 static gobos plus open

**Strobe:**

- Strobe effect with variable speed

**Motor:**

- 4 high quality stepping-motors controlled by microprocessors

**Electronics:**

- Intelligent control panel with 3-digit LED display allowing: addressing, drum reverse, effect calibration, reset of the unit and built-in demo sequences running
- Digital serial input DMX-512
- 6 control-channels:
  - Channel 1: Declination of the drum
  - Channel 2: Rotation of the drum round its rotation axis
  - Channel 3: Colour wheel
  - Channel 4: Gobo wheel
  - Channel 5: No function
  - Channel 6: Dimmer, strobe

**Temperatures:**

- Maximum ambient temperature : 45° C
- Maximum housing temperature : 80° C

**Minimum distances:**

- Min.distance from flammable surfaces: 0.5m
- Min.distance to lighted object: 0.8 m

**Dimensions:**

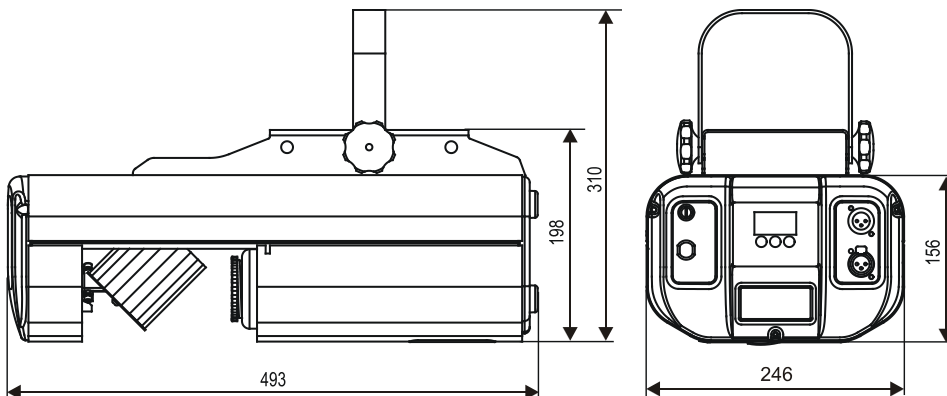

**Weight:**

11 kg (EU version), 14 kg (US version)

**Optional accessories:**

- Flash cable RS232/DMX .....No.13050624
- Mounting plate CT.....No.10980023

## 12. Maintenance and cleaning

***DANGER TO LIFE!***  
***Disconnect from mains before starting maintenance operation!***

It is absolutely essential that the fixture is kept clean and that dust, dirt and smoke-fluid residues must not build up on or within the fixture. Otherwise, the fixture's light-output will be significantly reduced. Regular cleaning will not only ensure the maximum light-output, but will also allow the fixture to function reliably throughout its life.

Please use a moist, lint-free cloth. Never use alcohol or solvents!

The mirror drum and the objective lens will require weekly cleaning as smoke-fluid tends to building up residues, reducing the light output very quickly. The cooling fan should be cleaned monthly.

The gobo wheel and colour wheel may be cleaned with a soft brush. The interior of the fixture should be cleaned at least annually using a vacuum-cleaner or an air-jet.

There are no serviceable parts inside the device except for the lamp and the fuse. Maintenance and service operations are only to be carried out by authorized distributors.

Please refer to the instructions under „Fitting/Exchanging the lamp“.

### **Replacing the fuse**

If the lamp burns out, the fine-wire fuse of the device might fuse too. Only replace the fuse by a fuse of the same type and rating .

**Before replacing the fuse, unplug mains lead.**

#### **Procedure:**

**Step 1:** Unscrew the fuse holder on the front panel with a fitting screwdriver from the housing (anti-clock-wise).

**Step 2:** Remove the old fuse from the fuseholder.

**Step 3:** Install the new fuse in the fuseholder.

**Step 4:** Replace the fuseholder in the housing and fix it.

Should you need any spare parts, please use genuine parts.

If the power supply cable of this device becomes damaged, it has to be replaced by authorized distributors only in order to avoid hazards.

Should you have further questions, please contact our distributor.