

ROBE

Color Wash 575 AT Zoom

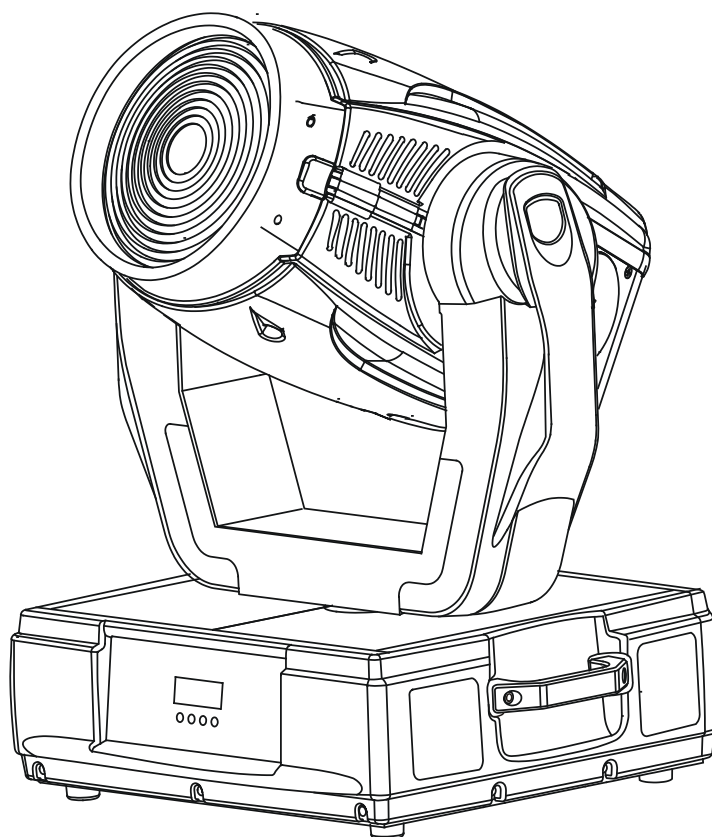

AT series

Version 1.4

USER MANUAL

ColorWash 575 AT Zoom

Table of contents

| | |
|--|-----------|
| 1. Safety instructions | 3 |
| 2. Operating determinations | 4 |
| 3. Description of the device | 5 |
| 4. Installation | 6 |
| 4.1 Fitting the lamp..... | 6 |
| 4.2 Lamp adjustment | 7 |
| 4.3 Inserting/Exchanging colours | 7 |
| 4.4 Connection to the mains | 8 |
| 4.5 Changing the power supply settings | 8 |
| 4.6 Changing the front lens | 9 |
| 4.7 Installing top hats | 9 |
| 4.8 Rigging the fixture | 10 |
| 4.9 DMX-512 connection/connection between fixtures | 12 |
| 5. ColorWash 575 AT Zoom-DMX Protocol-version 1.0 | 13 |
| 6. Controller mode | 16 |
| 6.1 DMX addressing..... | 16 |
| 6.2 Remotely controllable functions | 16 |
| 7. Stand - alone mode | 17 |
| 8. Control menu map | 18 |
| 9. Control menu | 21 |
| 9.1 Fixture Address | 21 |
| 9.2 Slave control | 21 |
| 9.3 Fixture informations..... | 21 |
| 9.4 Personality | 23 |
| 9.5 Lamp On/Off | 24 |
| 9.6 Manual mode | 24 |
| 9.7 Test sequences..... | 25 |
| 9.8 Stand-alone setting | 25 |
| 9.9 Reset function | 26 |
| 9.10 Special functions | 26 |
| 10. Low power mode | 27 |
| 11. Error and information messages | 27 |
| 12. Technical specifications | 29 |
| 13. Maintenance and cleaning | 31 |

CAUTION!
Keep this device away from rain and moisture!
Unplug mains lead before opening the housing!

**FOR YOUR OWN SAFETY, PLEASE READ THIS USER MANUAL CAREFULLY
BEFORE YOU INITIAL START - UP!**

1. Safety instructions

Every person involved with installation and maintenance of this device have to:

- be qualified
- follow the instructions of this manual

CAUTION!
Be careful with your operations.
With a high voltage you can suffer
a dangerous electric shock when touching the wires!

This device has left our premises in absolutely perfect condition. In order to maintain this condition and to ensure a safe operation, it is absolutely necessary for the user to follow the safety instructions and warning notes written in this manual.

Important:

The manufacturer will not accept liability for any resulting damages caused by the non-observance of this manual or any unauthorized modification to the device.

Please consider that damages caused by manual modifications to the device are not subject to warranty.

Never let the power-cord come into contact with other cables! Handle the power cord and all connections with the mains with particular caution!

Make sure that the available voltage is not higher than stated on the rear panel.

Always plug in the power plug least. Make sure that the power-switch is set to OFF-position before you connect the device to the mains. The power plug has to be accessible after installing the device.

Make sure that the power-cord is never crimped or damaged by sharp edges. Check the device and the power-cord from time to time.

Always disconnect from the mains, when the device is not in use or before cleaning it. Only handle the power-cord by the plug. Never pull out the plug by tugging the power cord.

This device falls under protection class I. Therefore it is essential to connect the yellow/green conductor to earth.

The electric connection, repairs and servicing must be carried out by a qualified employee. Do not connect this device to a dimmer pack.

Do not switch the fixture on and off in short intervals as this would reduce the lamp's life.

During the initial start-up some smoke or smell may arise. This is a normal process and does not necessarily mean that the device is defective.

Do not touch the device's housing bare hands during its operation (housing becomes hot)! For replacement use lamps and fuses of same type and rating only.

CAUTION ! EYEDAMAGES !
Avoid looking directly into the light source
(meant especially for epileptics) !

2. Operating determinations

This device is a moving-head for creating decorative effects and was designed for indoor use only.

If the device has been exposed to drastic temperature fluctuation (e.g. after transportation), do not switch it on immediately. The arising condensation water might damage your device. Leave the device switched off until it has reached room temperature.

Never run the device without lamp!

Do not shake the device. Avoid brute force when installing or operating the device.

Never lift the fixture by holding it at the projector-head, as the mechanics may be damaged. Always hold the fixture at the transport handles.

When choosing the installation-spot, please make sure that the device is not exposed to extreme heat, moisture or dust. There should not be any cables lying around. You endanger your own and the safety of others!

The minimum distance between light output and the illuminated surface must be more than 2 meters.

Make sure that the area below the installation place is blocked when rigging, derigging or servicing the fixture.

Always fix the fixture with an appropriate safety rope. Fix the safety rope at the correct holes only.

Only operate the fixture after having checked that the housing is firmly closed and all screws are tightly fastened.

The lamp must never be ignited if the objective-lens or any housing-cover is open, as discharge lamps may explode and emit a high ultraviolet radiation, which may cause burns.

The maximum ambient temperature 40°C must never be exceeded. Otherwise, the lamp is switched off and the fixture is out of operation for 5 minutes.

CAUTION!

The lens has to be replaced when it is obviously damaged, so that its function is impaired, e. g. due to cracks or deep scratches!

Operate the device only after having familiarized with its functions. Do not permit operation by persons not qualified for operating the device. Most damages are the result of unprofessional operation!

CAUTION!

The lamp has to be replaced when it is damaged or deformed due to the heat!

Please use the original packaging if the device is to be transported.

Please consider that unauthorized modifications on the device are forbidden due to safety reasons!

If this device will be operated in any way different to the one described in this manual, the product may suffer damages and the guarantee becomes void. Furthermore, any other operation may lead to dangers like short-circuit, burns, electric shock, burns due to ultraviolet radiation, lamp explosion, crash etc.

3. Description of the device

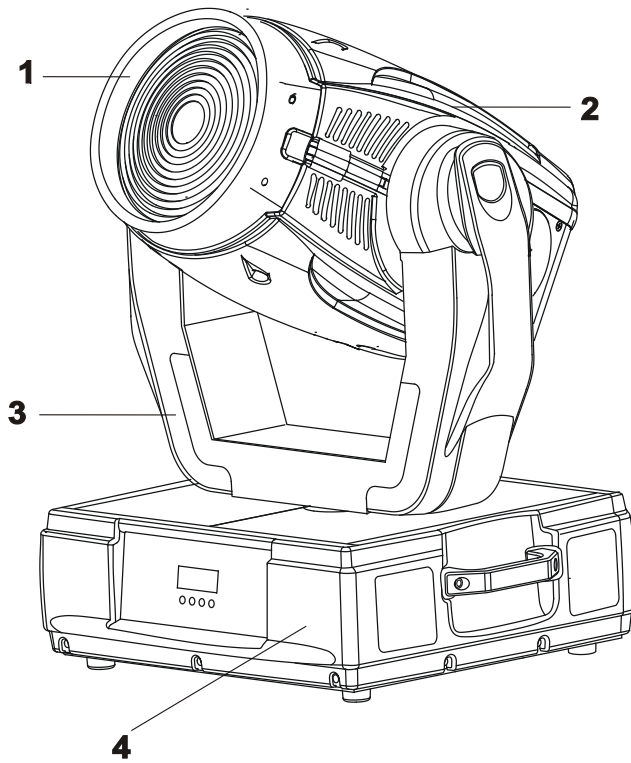

- 1 - Front lens
- 2 - Moving head
- 3 - Yoke
- 4 - Base

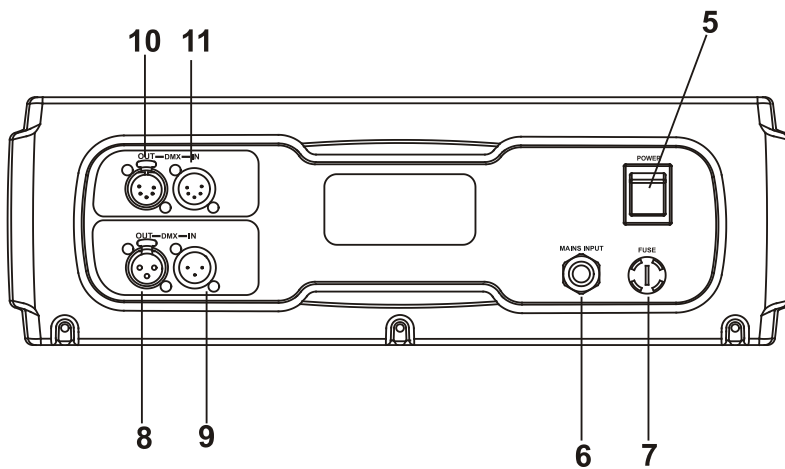

- Rear panel:**
- 5 - Power switch
 - 6 - Power cord
 - 7 - Fuse holder
 - 8 - 3-pin DMX output
 - 9 - 3-pin DMX input
 - 10 - 5-pin DMX output
 - 11 - 5-pin DMX input

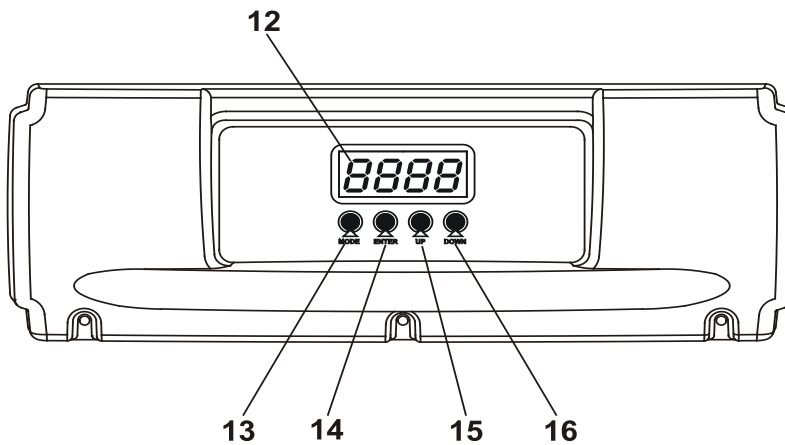

- Front panel:**
- 12 - Mode-button
 - 13 - Enter-button
 - 14 - Up-button
 - 15 - Down-button
 - 16 - Display

4. Installation

4.1 Fitting the lamp

DANGER !
Install the lamps with the device switched off only.
Unplug from mains before !

To insert the lamp loosen the lamp cover at the rear of head (see the drawings) by removing the 3 fastening screws which are marked "X,Y,Z". Carefully pull out the cover with the lamp socket assembly. If changing the lamp, remove the old lamp from the socket. Insert the lamp to the socket.

Do not install a lamp with a higher wattage! A lamp like this generates temperatures the device is not designed for. Damages caused by non-observance are not subject to warranty. Please follow the lamp manufacturer's notes! Do not touch the glass-bulb with bare hands during the installation! Make sure that the lamp is installed tightly into the lampholder system.

Reclose the lamp cover and tighten the 3 screws.

Before striking the lamp, reset the "LAti" and "LAST" counters in menu "InFO", by pressing the "Up" and "Down" buttons in one time and then confirming with the **Enter**-button.

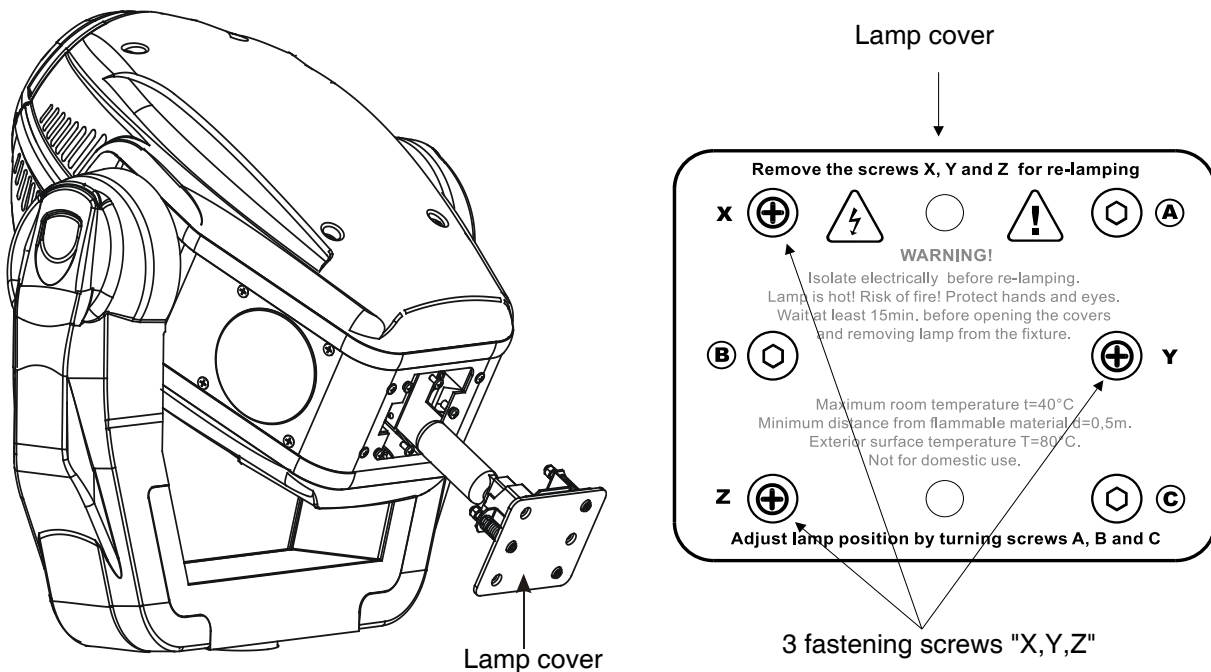

Do not operate this fixture with opened housing-cover!

4.2 Lamp adjustment

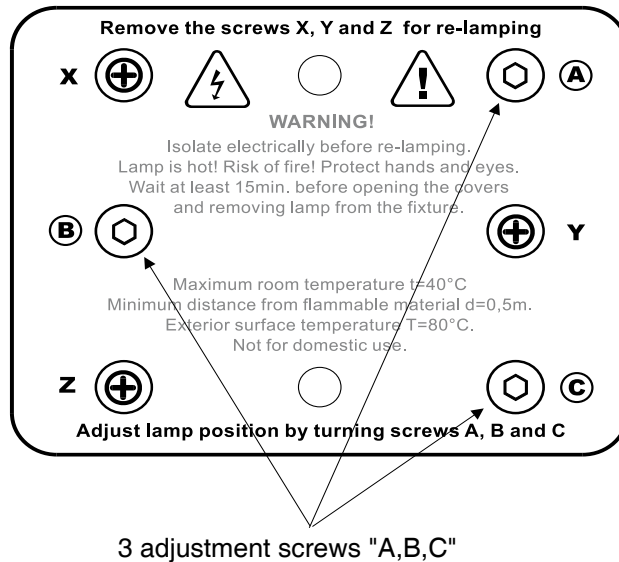

The ColorWash 575 AT Zoom lamp holder is aligned at the factory. Due to differences between lamps, fine adjustment may improve light performance.

Strike the lamp, open the shutter and set the dimmer intensity onto 100% and aim the light on a flat surface (wall). Center a hot-spot (the brightest part of the image) by using the 3 adjustment screws "A,B,C". Turn one screw after another a quarter-turn clockwise (counter-clockwise) to set the hot-spot in the center of the image. If you cannot detect the hot-spot, adjust the lamp until the light is evenly distributed.

4.3 Inserting/Exchanging colours

DANGER!
Install the colours with the device switched off only.
Unplug from mains before!

If you wish to change colours, open the top cover of the head by loosening 4 quarter-turn fasteners on the top cover.

Gently bend out the colour module to release it from the 3 distance slots and eject it from the pressing snap. Put the new colour module back under the pressing snap and push it to the distance slots.

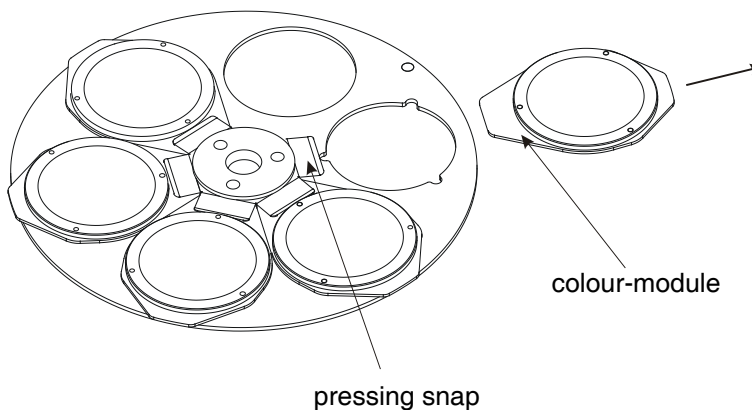

4.4 Connection to the mains

Verify the power supply settings before applying power!

If you wish to change the power supply settings, see the chapter below.

Connect the fixture to the mains with the power cord.

If the plug on the flexible cord is not the right type for your socket outlets, do not use an adaptor, but remove the plug from the cord and discard. Carefully prepare the end of the supply cord and fit a suitable plug.

The earth has to be connected!

Do not connect the fixture to a dimmer system!

The occupation of the connection-cables is as follows:

| Cable (EU) | Cable (US) | Pin | International |
|--------------|------------|---------|---|
| Brown | Black | Live | L |
| Light blue | White | Neutral | N |
| Yellow/Green | Green | Earth |  |

4.5 Changing the power supply settings

Both the transformer and the ballast must be connected correctly for the local AC voltage and frequency.

The wrong settings can cause poor performance or damage of the moving head. The factory settings are printed next to the power switch.

If you want to change the power supply settings, follow the instructions:

1. Disconnect the fixture from AC power.
2. Remove the top base covers by loosening the 12 fastening screws.
3. Move the wire ① on the transformer connection block to the position according to the desired voltage.
4. Move the wires ② and ③ on the ballast connection block to the position according to the desired frequency (voltage).
5. Close the base before applying AC power.

Examples:

EU-version:

Power supply settings: 230V/50Hz

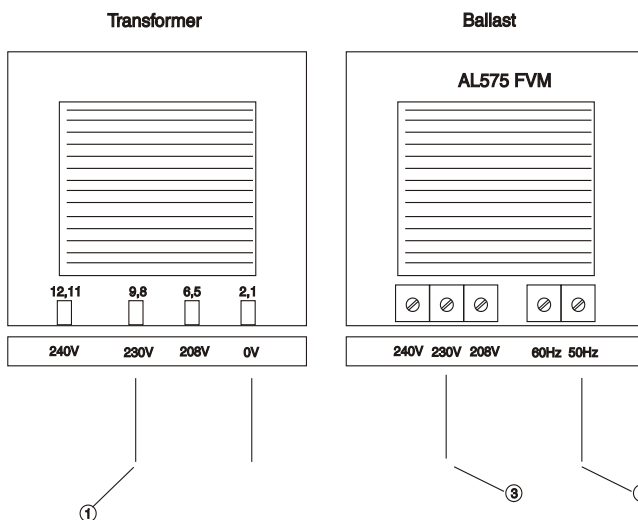

US-version:

Power supply settings: 120V/60Hz

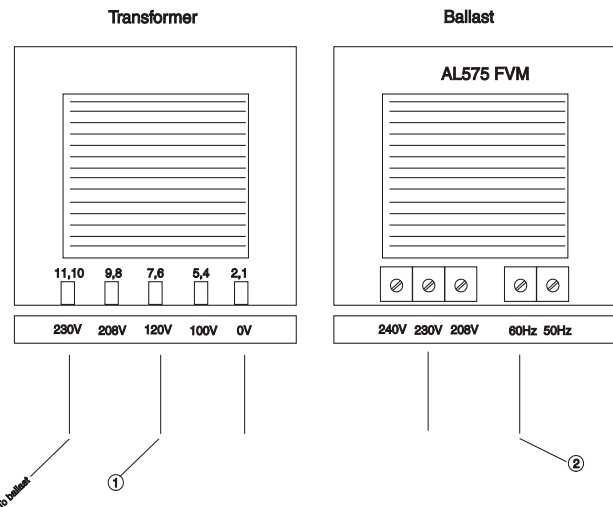

4.6 Changing the front lens

The ColorWash 575 AT Zoom is supplied with Fresnel lens as a standard front lens. If you wish to extend the zoom range, you may need optional front wide-angle lens D200.

| | |
|-----------------------|-------------|
| Front lens: | Beam angle: |
| Standard Fresnel lens | 8°-50° |
| Front wide-angle lens | 87° |

Switch the device off before changing the lens. Be careful. Front lens is heavy!

Changing the front Fresnel lens:

1. Remove the front lens module using a flathead screwdriver to unlock the four quarter-turn screws.
2. Unscrew the safety cable from the lens holder
3. Screw up the safety cable to the module of front wide-angle lens D200.
4. Place the module and fasten it by locking the four quarter-turn screws.

Quarter-turn screws

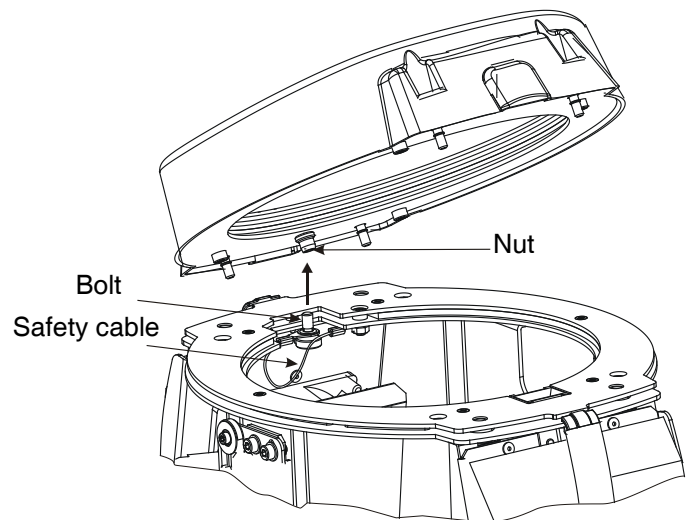
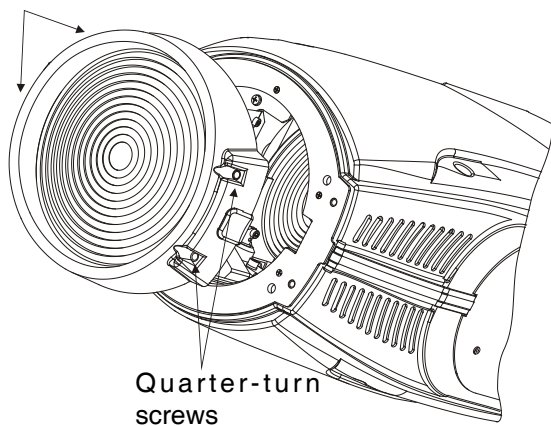

4.7 Installing top hats

The ColorWash 575E AT Zoom can be fitted with various types of the top hats-see chapter "Technical specifications". If you wish to install a top hat (optional), follow the instructions:

Switch the device off before installing the top hat!

Installing the top hat on the front lens-holder of the fixture:

1. Put desired top hat onto a front lens-holder and fasten it by two fastening screws.
2. Secure the top hat by means of two securing springs (hook first tip of the spring to the plastic projection in the front lens-holder and the second one snap to the slot in the top hat).

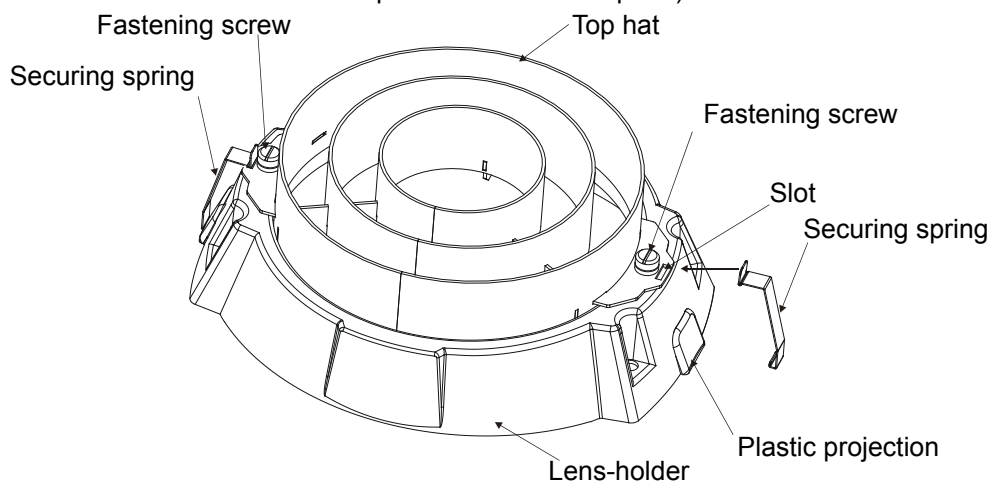

4.8 Rigging the fixture

DANGER TO LIFE!
Please consider the respective national norms during the installation!
The installation must only be carried out by an authorized dealer!

The installation of the projector has to be built and constructed in a way that it can hold 10 times the weight for 1 hour without any harming deformation.

The installation must always be secured with a secondary safety attachment, e.g. an appropriate catch net. This secondary safety attachment must be constructed in a way that no part of the installation can fall down if the main attachment fails.

When rigging, derigging or servicing the fixture staying in the area below the installation place, on bridges, under high working places and other endangered areas is forbidden.

The operator has to make sure that safety-relating and machine-technical installations are approved by an expert before taking into operation for the first time and after changes before taking into operation another time.

The operator has to make sure that safety-relating and machine-technical installations are approved by an expert after every four year in the course of an acceptance test.

The operator has to make sure that safety-relating and machine-technical installations are approved by a skilled person once a year.

The projector should be installed outside areas where persons may walk by or be seated.

IMPORTANT! OVERHEAD RIGGING REQUIRES EXTENSIVE EXPERIENCE, including (but not limited to) calculating working load limits, installation material being used, and periodic safety inspection of all installation material and the projector. If you lack these qualifications, do not attempt the installation yourself, but instead use a professional structural rigger. Improper installation can result in bodily injury and/or damage to property.

The projector has to be installed out of the reach of people.

If the projector shall be lowered from the ceiling or high joists, professional trussing systems have to be used. The projector must never be fixed swinging freely in the room.

Caution: Projectors may cause severe injuries when crashing down! If you have doubts concerning the safety of a possible installation, do NOT install the projector!

Before rigging make sure that the installation area can hold a minimum point load of 10 times the projector's weight.

Danger of fire !
When installing the device, make sure there is no highly inflammable material (decoration articles, etc.) in a distance of min. 0,7 m.

CAUTION!
Use 2 appropriate clamps to rig the fixture on the truss.
Follow the instructions mentioned at the bottom of the base.
Make sure that the device is fixed properly! Ensure that the structure (truss) to which you are attaching the fixtures is secure.

The projector can be placed directly on the stage floor or rigged in any orientation on a truss without altering its operation characteristics .

For overhead use, always install a safety-rope that can hold at least 10 times the weight of the fixture. You must only use safety-ropes with screw-on carabines. Pull the safety-rope through the two apertures on the bottom of the base and over the trussing system etc. Insert the end in the carabine and tighten the fixation screw.

Fixation via the omega holders

1. Bolt each clamp (1) to the omega holder (4) with M12 bolt and lock nut through the hole in the holder.
2. Fasten the omega holders on the bottom of the base by inserting both quick-lock fasteners (3) into the holes of the base and tighten fully clockwise.
3. Fasten the safety-rope (2) through the two apertures on the bottom of the base and over the trussing system.

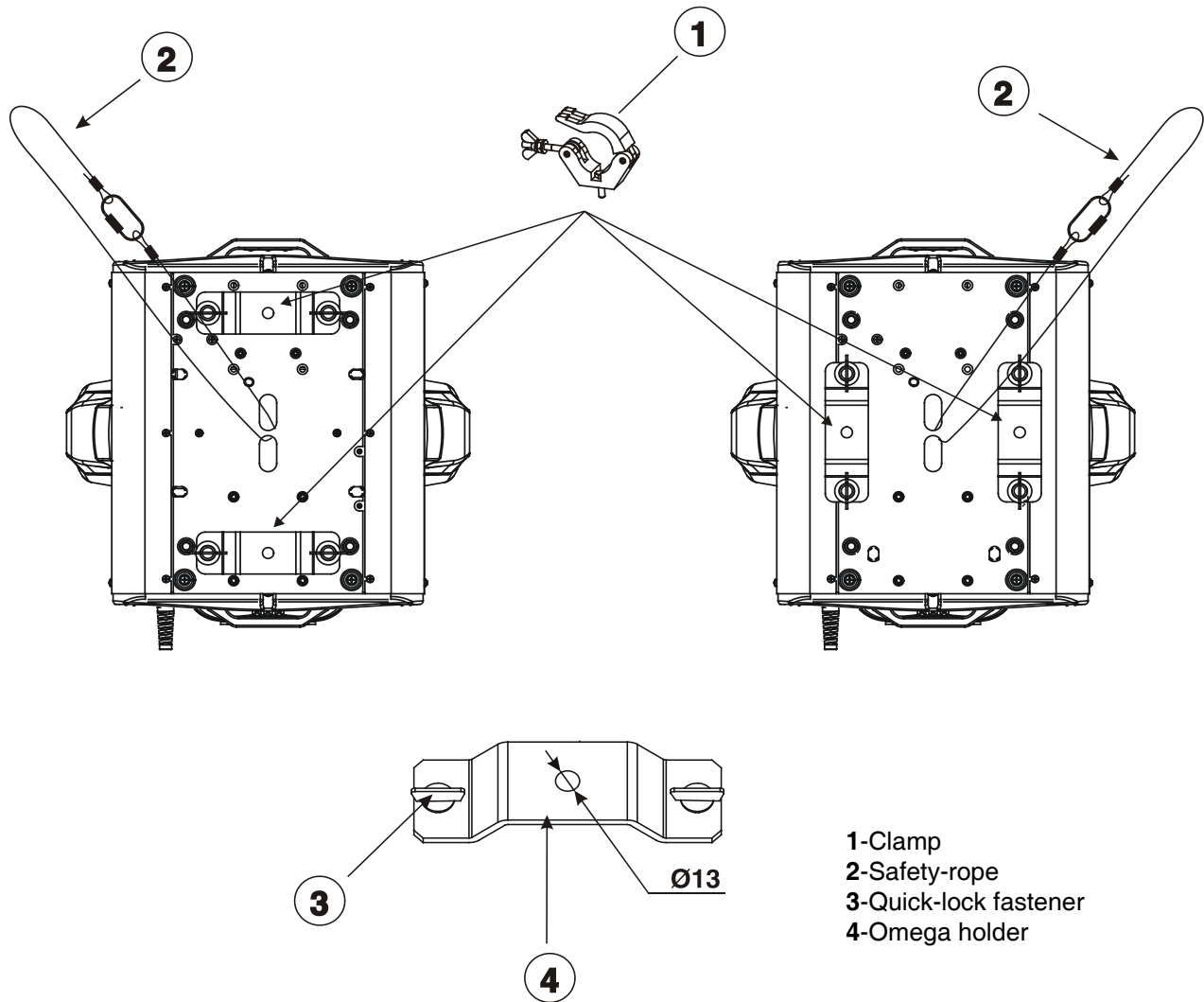

**When installing fixtures side-by-side,
avoid illuminating one fixture with another!**

DANGER TO LIFE!
Before taking into operation for the first time, the installation has to be approved by an expert!

4.9 DMX-512 connection/connection between fixtures

The fixture is equipped with both 3-pin and 5-pin XLR sockets for DMX input and output. The sockets are wired in parallel.

Only use a shielded twisted-pair cable designed for RS-485 and 3-pin or 5-pin XLR-plugs and connectors in order to connect the controller with the fixture or one fixture with another.

DMX - output

XLR mounting-sockets (rear view):

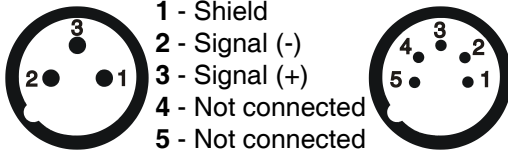

DMX-input

XLR mounting-plugs (rear view):

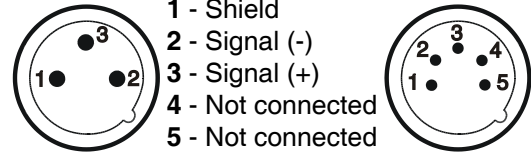

If you are using the standard DMX controllers, you can connect the DMX output of the controller directly with the DMX input of the first fixture in the DMX-chain. If you wish to connect DMX-controllers with other XLR-out-puts, you need to use adapter-cables.

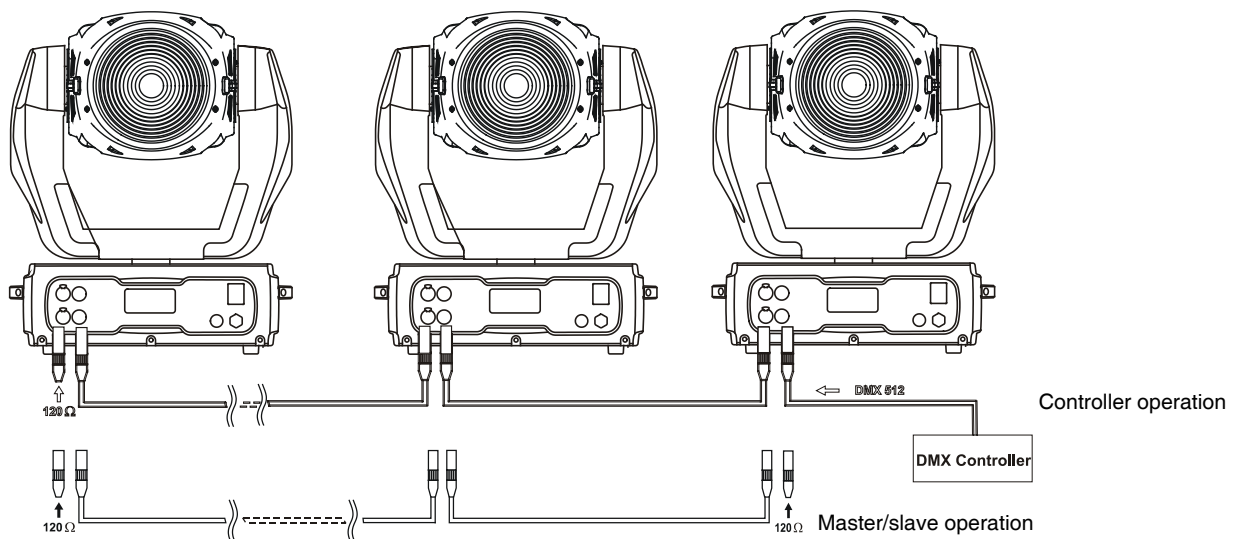

Building a serial DMX-chain:

Connect the DMX-output of the first fixture in the DMX-chain with the DMX-input of the next fixture. Always connect one output with the input of the next fixture until all fixtures are connected.

Caution: At the last fixture, the DMX-cable has to be terminated with a terminator. Solder a 120 Ω resistor between Signal (-) and Signal (+) into a 3-pin XLR-plug and plug it in the DMX-output of the last fixture.

Building a master/slave-chain:

Connect the DMX-output of the master fixture in the data-chain with the DMX-input of the first slave. Always connect output with the input of the next slave until all slaves are connected (up to 9 fixtures).

Caution: It's necessary to insert the XLR termination plug (with 120 Ohm) into the input of the master fixture and into the output of the last slave fixture in the link in order to ensure proper transmission on the data link.

5. ColorWash 575 AT Zoom-DMX Protocol-version 1.0

| Mode/Channel | | | | Value | Function | Type of control |
|--------------|----------|------|---|-----------|--|-----------------|
| 1 | 2 | 3 | 4 | | | |
| 1 | 1 | 1 | 1 | 0 - 255 | Pan Pan movement by 530° | proportional |
| 2 | 2 | 2 | 2 | 0 - 255 | Pan Fine Fine control of pan movement | proportional |
| 3 | 3 | 3 | 3 | 0 - 255 | Tilt Tilt movement by 280° | proportional |
| 4 | 4 | 4 | 4 | 0 - 255 | Tilt fine Fine control of tilt movement | proportional |
| 5 | 5 | 5 | 5 | 0 | Pan/Tilt speed , Pan/Tilt time Max. speed (tracking mode) | step |
| | | | | 1 - 255 | <i>P./T. speed-set Speed Mode in menu: Pan/Tilt Mode</i> Speed from max. to min. (vector mode) | proportional |
| | | | | 1 - 255 | <i>P./T. time - set Time Mode in menu: Pan/Tilt Mode</i> Time from 0,1 s to 25,5 s. * | proportional |
| 6 | 6 | 6 | 6 | 0 - 49 | Power/Special functions Reserved <i>To activate following functions, stop in DMX value for at least 3 s and shutter must be closed at least 3 s. („Shutter, Strobe” channel 17 (15,19,17) must be at range: 0-31 DMX). **</i> | step |
| | | | | 50 - 59 | Pan/Tilt speed mode | step |
| | | | | 60 - 69 | Pan/Tilt time mode | step |
| | | | | 70 - 79 | Blackout while pan/tilt moving | step |
| | | | | 80 - 89 | Disabled blackout while pan/tilt moving | step |
| | | | | 90 - 99 | Blackout while colour wheel moving | step |
| | | | | 100 - 109 | Disabled blackout while colour wheel moving | step |
| | | | | 110 - 129 | Reserved <i>To activate following functions, stop in DMX value for at least 3 s.</i> | step |
| | | | | 130 - 139 | Lamp On,reset(total reset except pan/tilt reset) | step |
| | | | | 140 - 149 | Pan/Tilt reset | step |
| | | | | 150 - 159 | Colour system reset | step |
| | | | | 160 - 169 | Reserved | step |
| | | | | 170 - 179 | Dimmer/Strobe reset | step |
| | | | | 180 - 189 | Zoom module reset | step |
| | | | | 190 - 199 | Reserved | step |
| | | | | 200 - 209 | Total reset | step |
| 210 - 229 | Reserved | step | | | | |
| 230 - 239 | Lamp Off | step | | | | |
| 240 - 255 | Reserved | step | | | | |
| | | 7 | 7 | 0 - 9 | Pan/Tilt macro selection Disabled pan/tilt macro | step |
| | | | | 10 - 31 | Reserved | step |
| | | | | 32 - 63 | Figure of circle (from small to large) | proportional |
| | | | | 64 - 95 | Figure of horizontal eight (from small to large) | proportional |
| | | | | 96 - 127 | Figure of vertical eight (from small to large) | proportional |
| | | | | 128 - 159 | Figure of rectangle (from small to large) | proportional |
| | | | | 160 - 191 | Figure of triangle (from small to large) | proportional |
| | | | | 192 - 223 | Figure of star (from small to large) | proportional |
| | | | | 224 - 255 | Figure of cross (from small to large) | proportional |
| | | 8 | 8 | 0 | Pan/Tilt macro speed <i>(Set pan/tilt speed (channel 5) to 0)</i> No macro generation | step |
| | | | | 1 - 127 | Macro generation from fast to slow-forwards | proportional |
| | | | | 128 - 129 | No macro generation | step |
| | | | | 130 - 131 | Macro generation from slow to fast-backwards | proportional |
| | | | | 132 - 255 | Macro generation from slow to fast-backwards | proportional |

| Mode/Channel | | | | Value | Function | Type of control |
|--------------|--|--------------|----|---------|---|-----------------|
| 1 | 2 | 3 | 4 | | | |
| 7 | 7 | 9 | 9 | 0 | Colour wheel <i>Continual positioning</i> Open/white | proportional |
| | | | | 21 | Deep red | proportional |
| | | | | 43 | Deep blue | proportional |
| | | | | 64 | Green | proportional |
| | | | | 85 | 6000K correction filter | proportional |
| | | | | 107 | UV filter | proportional |
| | | | | 128-129 | White | proportional |
| | | | | 130-141 | <i>Positioning</i> Deep red | step |
| | | | | 142-153 | Deep blue | step |
| | | | | 154-165 | Green | step |
| | | | | 166-177 | 6000K correction filter | step |
| 178-189 | UV filter | step | | | | |
| 190 - 215 | Forwards rainbow effect from fast to slow | proportional | | | | |
| 216 - 217 | No rotation | step | | | | |
| 218 - 243 | Backwards rainbow effect from slow to fast | proportional | | | | |
| 244 - 249 | Random colour selection by audio control (Set microphone sensitivity in menu „Personality”) | step | | | | |
| 250 - 255 | Auto random colour selection from fast to slow | proportional | | | | |
| 8 | | 10 | | 0 - 255 | Colour wheel - fine positioning Fine positioning | proportional |
| 9 | 8 | 11 | 10 | 0 - 255 | Cyan Cyan (0-white, 255-full cyan) | proportional |
| 10 | 9 | 12 | 11 | 0 - 255 | Magenta Magenta (0-white, 255-full magenta) | proportional |
| 11 | 10 | 13 | 12 | 0 - 255 | Yellow Yellow (0-white, 255-full yellow) | proportional |
| 12 | 11 | 14 | 13 | 0 - 255 | Conversion temperature filter 3200K (0-7200K, 255-3200K) | proportional |
| 13 | 12 | 15 | 14 | 0 - 255 | Speed of CMY and conv.temp. filter Speed from max. (0) to min.(255) | proportional |
| 14 | 13 | 16 | 15 | 0 - 7 | CMY colour macros No function | step |
| | | | | 8 - 15 | Macro 1 | step |
| | | | | 16 -23 | Macro 2 | step |
| | | | | 24-31 | Macro 3 | step |
| | | | | 32-39 | Macro 4 | step |
| | | | | 40-47 | Macro 5 | step |
| | | | | 48-55 | Macro 6 | step |
| | | | | 56-63 | Macro 7 | step |
| | | | | 64-71 | Macro 8 | step |
| | | | | 72-79 | Macro 9 | step |
| | | | | 80-87 | Macro 10 | step |
| | | | | 88-95 | Macro 11 | step |
| | | | | 96-103 | Macro 12 | step |
| | | | | 104-111 | Macro 13 | step |
| | | | | 112-119 | Macro 14 | step |
| | | | | 120-127 | Macro 15 | step |
| | | | | 128-135 | Macro 16 | step |
| | | | | 136-143 | Macro 17 | step |
| | | | | 144-151 | Macro 18 | step |
| | | | | 152-159 | Macro 19 | step |
| | | | | 160-167 | Macro 20 | step |
| | | | | 168-175 | Macro 21 | step |
| 176-183 | Macro 22 | step | | | | |

| Mode/Channel | | | | Value | Function | Type of control |
|--------------|--------------|------|----|-----------|--|-----------------|
| 1 | 2 | 3 | 4 | | | |
| 14 | 13 | 16 | 15 | 184-191 | Macro 23 | step |
| | | | | 192-199 | Macro 24 | step |
| | | | | 200 - 207 | Macro 25 | step |
| | | | | 208 - 215 | Macro 26 | step |
| | | | | 216 - 223 | Macro 27 | step |
| | | | | 224 - 231 | Macro 28 | step |
| | | | | 232 - 239 | Macro 29 | step |
| | | | | 240 - 243 | Macro 30 - Random rainbow effect from fast to slow | proportional |
| | | | | 244 - 249 | Random macro selection by audio control (Set microphone sensitivity in menu "PErS") | step |
| | | | | 250 - 255 | Auto random macro selection from fast to slow | proportional |
| 15 | 14 | 17 | 16 | 0 - 255 | Zoom Coarse zoom from min. to max.beam angle | proportional |
| 16 | | 18 | | 0 - 255 | Zoom fine Fine zoom movement | proportional |
| 17 | 15 | 19 | 17 | 0 - 31 | Shutter, strobe Shutter closed, | step |
| | | | | 32 - 63 | Shutter open, | step |
| | | | | 64 - 95 | Strobe-effect from slow to fast (max.15 flashes/s) | proportional |
| | | | | 96 - 127 | Shutter open, | step |
| | | | | 128 - 143 | Opening pulse in sequences from slow to fast | proportional |
| | | | | 144 - 159 | Closing pulse in sequences from fast to slow | proportional |
| | | | | 160 - 191 | Shutter open | step |
| | | | | 192 - 223 | Random strobe-effect from slow to fast | proportional |
| 224 - 255 | Shutter open | step | | | | |
| 18 | 16 | 20 | 18 | 0 - 255 | Dimmer intensity Dimmer intensity from 0% to 100% | proportional |
| 19 | | 21 | | 0 - 255 | Fine dimmer intensity Dimmer intensity fine | proportional |

Notes:

* Short times are not used for long tracks (e.g. 0.5s for track 0-255 DMX). Times are restricted by the mechanical parameters of the fixture.

** The switch-functions have priority to the equivalent functions in menu "Personality"but the setting by DMX is not saved to the memory(after switching the fixture on,the setting from menu "Personality" is loaded and after that can be changed with DMX value on the channel 6).

| <u>DMX protocol</u> | <u>menu "PerS"</u> |
|---|-----------------------|
| 50-59 Pan/Tilt speed mode | P.t.Mo.--->SP.Mo. |
| 60-69 Pan/Tilt time mode | P.t.Mo.--->ti.Mo. |
| 70-79 Blackout while pan/tilt moving | A.blc.-->P.t.M.-->On |
| 80-89 Disabled blackout while pan/tilt moving | A.blc.-->P.t.M.-->Off |
| 90-99 Blackout while colour wheel moving | A.blc.-->Col.M.-->On |
| 100-109 Disabled blackout while colour wheel moving | A.blc.-->Col.M.-->Off |

6. Controller mode

The fixtures are individually addressed on a data link and connected to the controller. The fixtures respond to the DMX signal from the controller.

6.1 DMX addressing

The control panel on the front panel of the fixture allows you to assign the DMX fixture address, which is defined as the first channel from which the ColorWash 575 AT Zoom will respond to the controller.

If you set, for example, the address to channel 20, the ColorWash 575 AT Zoom will use the channel 20 to 37 for control (if mode 1 is selected).

Please, be sure that you don't have any overlapping channels in order to control each ColorWash 575 AT Zoom correctly and independently from any other fixture on the DMX data link.

If two, three or more ColorWash 575 AT Zoom are addressed similarly, they will work similarly.

For address setting, please refer to the instructions under "Addressing"(menu "A001").

Controlling:

After having addressed all ColorWash 575 AT Zoom, you may now start operating these via your lighting controller.

Note:After switching on, the ColorWash 575 AT Zoom will automatically detect whether DMX 512 data is received or not. If there is no data received at the DMX-input, the display will start to flash "A001" with actually set address.

This situation can occur if:

- the 3 PIN (5pin) XLR plug (cable with DMX signal from controller) is not connected with the input of the ColorWash 575 AT Zoom
- the controller is switched off or defective, the cable or connector is defective or the signal wires are swap in the input connector.

Note:It's necessary to insert the XLR termination plug (with 120 Ohm) to the last fixture in the link in order to ensure proper transmission on the DMX data link.

6.2 Remotely controllable functions

Lamp

The ColorWash 575 AT Zoom is to be operated with a Philips MSR 575/2 lamp.

A relay inside of the ColorWash 575 AT Zoom allows you to switch on and off the lamp via the control panel or via your DMX-controller without affecting the rest of the lighting.

To switch On/Off the lamp, please refer to "Switching On/Off the lamp" (menu **LAMP**).

Note:It is also important to note, that the discharge lamp is cold restrike types, that means, that they have to be cold before re-striking. For this reason, you have to wait 5 minutes (max. speed of fan must be adjusted) after having switched Off the lamp before you can switch it back On again. If you try to switch On the lamp within 5 minutes after having switched it Off, the ColorWash 575 AT Zoom will store this information and automatically ignite the lamp when the 5 minutes period has expired. The message "HEAt" will appear on the control panel display of the ColorWash 575 AT Zoom. If the ignition of the lamp is seven times unsuccessful, on the display will appear "LA.Er", meaning that the lamp could be damaged or even missed, or there could be a failure on the ignitor or ballast.

Colour wheel

This wheel contains 5 replaceable 'SLOT&LOCK' dichroic filters + open. The colour-wheel can be positioned between two adjacent colours in any position. It is also possible to rotate the colour wheel continuously at different speeds ("Rainbow effect" in both directions).

Zoom

Motorized zoom unit enables zoom between 8° and 50° beam angle.

Dimmer/Shutter/Strobe

Smooth 0 - 100 % dimming is provided by the combined mechanical dimmer/shutter unit. This unit may also be used for strobe effect.

7. Stand - alone mode

The fixtures on a data link are not connected to the controller but can execute pre-set programs which can be different for every fixture. To set the program to be played, see the "Stand-alone setting" (menu "St.AL.").

"Stand-alone operation" can be applied to the single fixture (the fixture may be set to the master /slave mode or controller mode) or to multiple fixtures operating synchronously.

Synchronous operation of multiple fixtures requires that they must be connected on a data link and one of them is set as a master (master mode) and the rest as the slaves (slave mode). The slaves are assigned to SLA1-SLA9 and on the certain slave address can be connected only one fixture. To set the fixture as the master or slave , see the "Addressing" (menu "A001").

If the master fixture runs a reset, switches On/Off the lamp or plays test(program) ,all slaves will execute these acts too (e.g. if the master fixture has switched the lamp off, no slaves can switch the lamp on)!

The master fixture starts simultaneous program start in the other slave fixtures. All fixtures have a definite, synchronized starting point when playing back their programs. The number of running program is the same in all slaves and depends on the master's choice (menu "St.AL."). Every fixture runs its program repeatedly , starting the program step No.1 when requested by the master .

For example:

If the slave fixture has a shorter program length, it will continuously repeat its program until the master fixture finishes its own program and restarts its program running (slave 1- prog.step 3 will not be finished).

If the slave fixture has a longer program length, it will restart at prog. step 1 before it completes all its prog.steps

(slave 2 - prog.step 5 will not be played)- see the picture bellow.

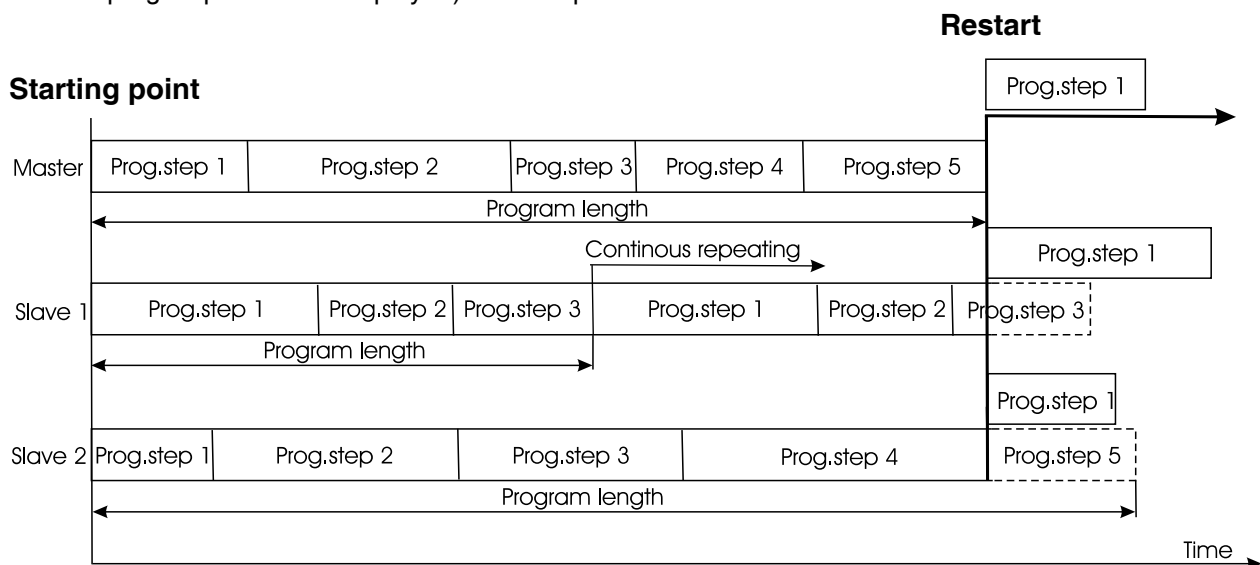

Note: Disconnect the fixtures from the DMX controller before master/slave operating , otherwise data collisions can occur and the fixtures will not work properly!

8.Control menu map

Default settings=**Bold print**

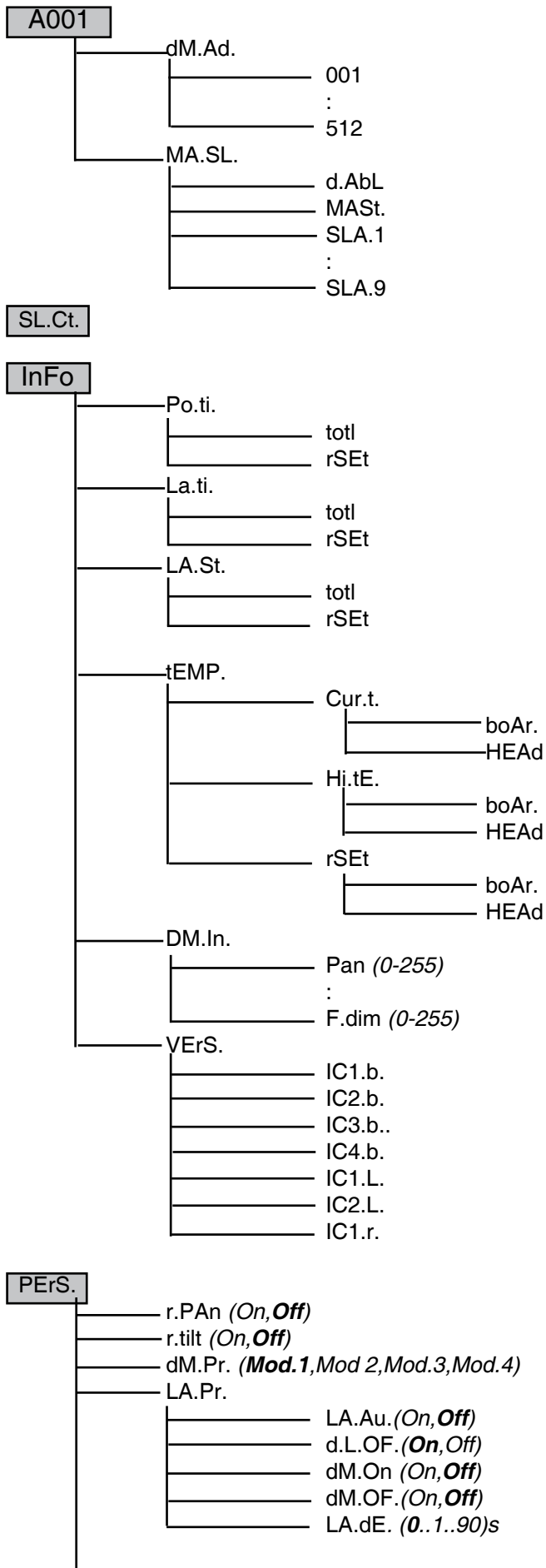

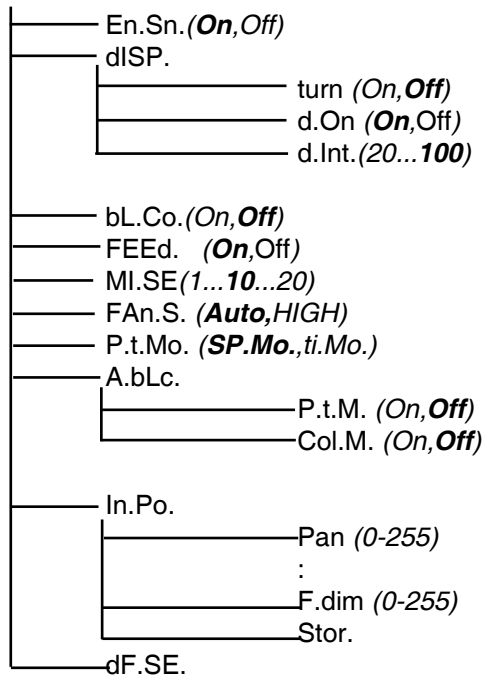

LAMP (**On, Off**)

MAn.M.

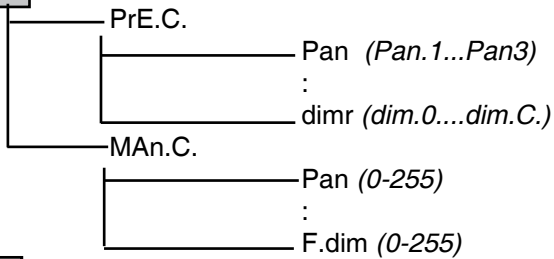

tEst

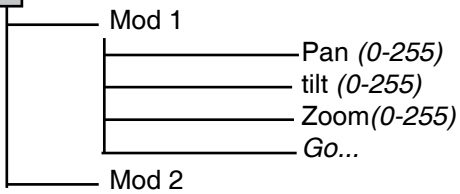

St.AL.

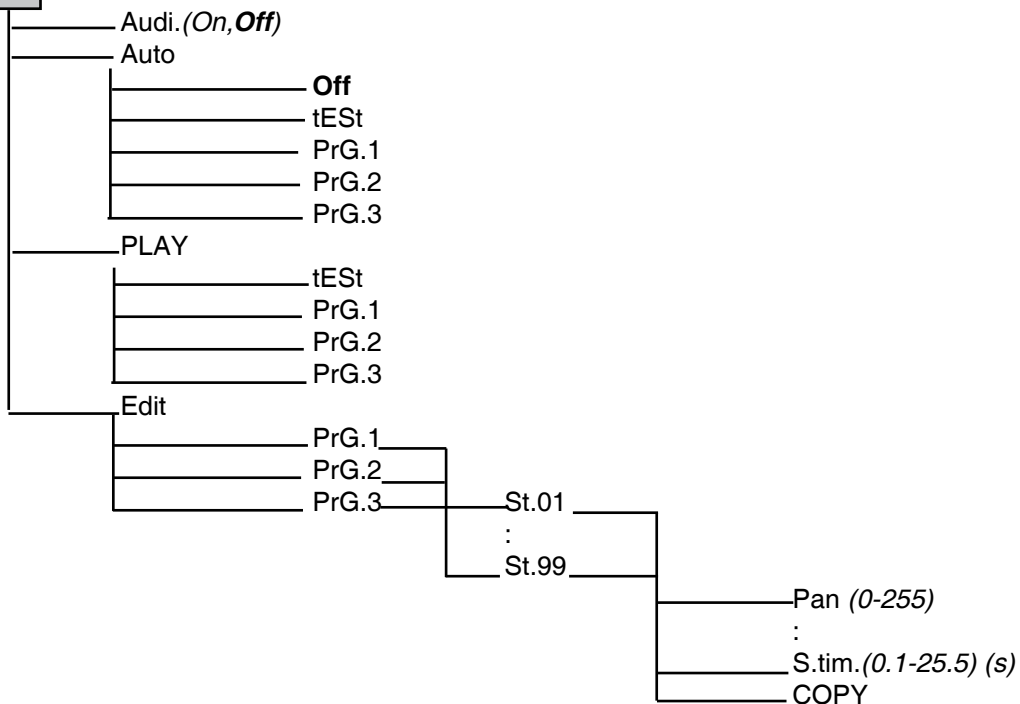

rESE.

SPEC.

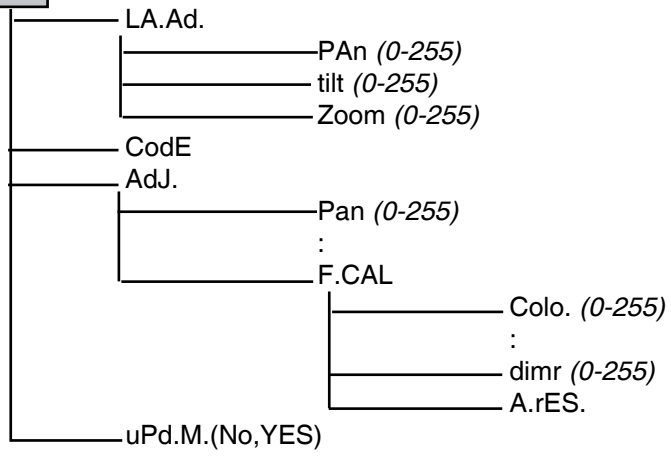

9. Control menu

The control panel situated on the front panel of the base offers several features. You can simply set the DMX address, read the number of the lamp or unit hours, switch On and Off the lamp, run test, make a reset and also use many functions for setting fixture behaviour.

Control elements on the control board:

[MODE] button-leaves menu without saving changes.

[ENTER] button- enters menu, confirms adjusted values and leaves menu.

[UP] button and [DOWN] button- moves between menu items on the the same level, sets values.

After switching the fixture on, the display shows the initial screen:



Use [UP],[DOWN] to browse through the menu. To select a function or submenu, press [ENTER].

9.1 Fixture Address



Use this menu to set the DMX address of the fixture or set the fixture as a Master (Slave).

dM.Ad. --- **DMX addressing.** Select this submenu to set DMX start address.

MA.SL. --- **Master/slave addressing.** Select this submenu to set the fixture as a Master or Slave (Slave 1- Slave 9). Option "d.AbL" deactivates master/slave setting.

9.2 Slave control



This function allows you to control the slaves from the master's control panel in a master/slave operation. Select this function from the main menu and press [ENTER]. Browse the list of all connected slaves ("SL.C.1" - "SL.C.9") by pressing [UP] or [DOWN]. Select the desired slave and press [ENTER]-button. The matching slave control panel is available from the master control panel.

Note: This function is available from the master fixture only.

9.3 Fixture informations



Use this menu to read an useful information about the fixture.

Po.ti. --- **Power on time.** Select this submenu to read the number of operation hours.

totL --- The function shows the total number of the operation hours since the ColorWash 575 AT Zoom has been fabricated.

rSEt --- The function shows the number of the operation hours that the ColorWash 575 AT Zoom has been powered on since the counter was last reset. In order to reset this counter to 0 you have to hold [UP] and [DOWN] and press the [ENTER].

La.ti. --- **Lamp on time.** Select this submenu to read the number of the operation hours with the lamp on.

totL --- The function shows the total number of the operation hours with the lamp on since the ColorWash 575 AT Zoom has been fabricated.

rSEt --- The function shows the number of the operation hours with the lamp on that the

ColorWash 575 AT Zoom has been powered on since the counter was last reset. In order to reset this counter to 0 you have to hold [UP] and [DOWN] and press the [ENTER].

LA.St. --- Lamp strikes. Select this submenu to read the total number of the lamp strikes.

totL --- The function shows the total number of the lamp strikes since the ColorWash 575 AT Zoom has been fabricated.

rSEt --- The function shows the number of the lamp strikes since the counter was last reset. In order to reset this counter to 0 you have to hold [UP] and [DOWN] and press [ENTER].

tEMP --- Fixture temperatures. Select this submenu to read the fixture temperatures (°C). Please note that the outside temperature should not exceed 40° C.

Cur.t. --- Current fixture temperatures.

boAr. - Current temperature on the main board in the base of the fixture. Temperatures above 66°C lead to the lamp being switched off and the fixture goes to "low power mode". Before switching the lamp on again (after 5 minutes), run a total fixture reset.

HEAd - Current temperature of the head inside. Temperatures below 66°C are not critical. 66° C and more lead to the lamp being switched off and the fixture goes to "low power mode". Before switching the lamp on again (after 5 minutes), run a total fixture reset.

Hi.tE. --- Maximum fixture temperatures.

boAr. - The function shows the max. temperature on the main board since the ColorWash 575 AT Zoom has been fabricated.

HEAd - The function shows the max. temperature of the head inside since the ColorWash 575 AT Zoom has been fabricated.

rSEt --- Maximum resetable temperatures.

boAr. - The function shows the maximum temperature on the main board since the counter was last reset. In order to reset the counter to 0 you have to hold [UP] and [DOWN] and press the [ENTER].

HEAd - The function shows the maximum temperature of the head inside since the counter was last reset. In order to reset the counter to 0 you have to hold [UP] and [DOWN] and press the [ENTER].

DM.In. --- Readout of DMX values. Select this function to read DMX values (0-255) of each channel received by the fixture.

PAn a coarse pan movement
F.PAn a fine pan movement
tilt a coarse tilt movement
F.tilt a fine tilt movement
SpEd a pan/tilt speed
P.t.SE. a pan/tilt macro selection
P.t.SP. a pan/tilt macro speed
Func. a special function
Colo. a colour wheel
F.Col. a fine colour wheel
CYAN a cyan lamella
MAGE. a magenta lamella

MAGE. a magenta lamella
YELL. a yellow lamella
CtC.F. a CTC filter
C.SPd. a CMY/CTC/dimmer speed
Macr. a CMY macros
Zoom a zoom
F.Zom a fine zoom
Stro. a shutter, strobe
dimr a dimmer
F.dim. a fine dimmer

VErS. --- Software version. Select this function to read the software version of processors:

IC1.b. --- Main processor on the main board in the fixture base

IC2.b. --- Pan processor on the main board in the fixture base

IC3.b. --- Tilt processor on the main board in the fixture base

IC4.b. --- EEPROM on the main board in the fixture base

IC1.L. --- Processor 1 in the left arm of the fixture

IC2.L. --- Processor 2 in the left arm of the fixture

IC1.r. --- Processor 1 in the right arm of the fixture

9.4 Personality



Use this menu to modify ColorWash 575 AT Zoom operating behavior.

r.PAn --- **Pan reverse**. Select this function to invert the pan movement.

r.tilt --- **Tilt reverse**. Select this function to invert the tilt movement.

DM.Pr. --- **DMX presetting**. Select this function to set desired effects assigning to the channels. Please refer to the chapter "DMX protocol" for detail description.

LA.Pr. --- **Lamp presetting**. Select this menu to change the lamp "behaviour".

LA.Au. --- Select this function to turn the lamp on automatically after switching the fixture on.

d.L.OF. --- Select this function to switch off the lamp via DMX.

dm.On --- This function allows you to strike the lamp automatically after 26 seconds if DMX signal is present on the data link. If the ignition is unsuccessful (e.g. lamp is too hot), the fixture will try to ignite the lamp after next 26 s. This process will repeat until the lamp lights.

dm.OF. --- This function allows you to switch Off the lamp automatically after 2 minutes if DMX signal is missing on the data link.

LA.dE. --- Lamp ignition delay. This function allows you to set the time delay (0-90s) before the lamp will be ignited. This setting will not affect starting the lamp direct from the control panel (menu "Lamp On/Off").

En.Sn. --- **Switching on/of the lamp light sensor**. Select this function to switch the lamp light sensor on or off. The option "On" is for the standard operation.

Important: The option "Off" is for "emergency operation" only if the lamp light sensor is defective and you will wait for a service intervention! If the lamp light sensor is switched off and at switching the lamp on the electronics will still try to ignite the lamp until it shines (even when the lamp is damaged or absent), on this account some electronics parts could be damaged!

DiSP. --- **Display adjusting**. This function allows you to change the display settings.

turn --- Select this function to turn the display by 180°.

d.On --- This function allows you to keep the display on or to turn off automatically 2 minutes after last pressing any button on the control panel.

d.Int. --- Select this function to adjust the display intensity (20-min., 100-max.).

bL.Co. --- **Blackout during movement correction**. Select this function to enable the blackout during the head movement correction (if the moving head lost its right pan/tilt position for a short moment).

FEEd --- **Pan/Tilt feedback**. This function allows to return the moving head to the required pan/tilt position after changing the position by external force (e.g. by stroke).

Be careful, the Pan/Tilt Feedback OFF is not the standard operation and the head of the fixture can be damaged!

Note: If the feedback was switched off, the pan/tilt-position is changed by an external force and the feedback is switched on again, the moving head might not to be synchronized with the DMX signal. You have to make a reset in order to synchronize the moving head with the DMX signal.

Mi.SE. --- **Microphone sensitivity**. Select this function to adjust the microphone sensitivity from 1 (maximum) to 20 (minimum). If the sensitivity is correctly adjusted, the upper segment of the first digit blinks in the bass beat.

Examples:



underexited



right level



overexited

(upper segment blinks via the bass rhythm)

Fan.S. --- Fan speed operating modes.By using this function you can choose 2 types of the fan speed operating modes.

Auto --- The fans automatically raise their speed in order to control inside temperature of the head, if the temperature inside increases about certain level (the low fan speed reduces the cooling of the lighting). This cycle can repeat several times until the temperature inside is on a suitable level.

HIGH --- The cooling fans work on max. speed (max. cooling).This mode we recommend for high ambient temperature (30 °C and more).

P.t.Mo. --- Pan/tilt movement mode.Use this menu to set the character of the pan/tilt movement.

ti.Mo. --- Time mode.Pan and tilt will move with different speeds and they will come at the same time to end point (pan and tilt sets its optimal speed).

SP.Mo. --- Speed mode.Pan and tilt will move with the same speed as adjusted by the channel 5 (Pan/Tilt speed).E.g. pan will come to the end point and wait for tilt,which has longer track.

A.blc. --- Automatic blackout.Use this function if you wish to close the light output during effect changes.

P.t.M. --- This function closes the light output during pan/tilt changes.

Col.M. --- This function closes the light output during colour wheel changes.

In.Po. --- Init effect positions.Select this function to adjust all effects to the desired initial positions.After switching the fixture on (if DMX is not connected),all effects will move to initial positions. Use the [UP] and [DOWN] buttons to select desired channel and press [ENTER].Set the effect to the desired position using [UP] and [DOWN] buttons and confirm by pressing [ENTER].After having adjusted required effects,select "Stor." to save all initial values to the memory.

dF.SE. --- Default Settings .Select this option to reset all fixture personalities to the default values.

9.5 Lamp On/Off



Use this option in order to switch on/off the lamp.It is also important to note, that the lamp is cold restrike type, that means, that it has to be cold before striking.

9.6 Manual mode



Select this menu to call up presetted positions of channel effects or direct control channel effects.

PrE.C. --- Presetted effect control.Select this menu to call up presetted positions of the channel effects.

Man.C. --- Manual effect control.Select this menu to control effects by control buttons on the control board.

PAn a coarse pan movement
F.PAn a fine pan movement
tilt a coarse tilt movement
F.tilt a fine tilt movement
SpEd a pan/tilt speed
P.t.SE. a pan/tilt macro selection
P.t.SP. a pan/tilt macro speed
Func. a special function
Colo. a colour wheel
F.Col. a fine colour wheel
CYAN a cyan lamella
MAGE. a magenta lemella

MAGE. a magenta lemella
YELL. an yellow lamela
CtC.F. a CTC filter
C.SPd. a CMY/CTC/dimmer speed
Macr. a CMY macros
Zoom a zoom
F.Zom a fine zoom
Stro. a shutter,stroke
dimr a dimmer
F.dim. a fine dimmer

9.7 Test sequences



Use this menu to to run a special demo-test sequences without an external controller, which will show you some possibilities of using ColorWash 575 AT Zoom.

Mod. 1 --- Mode 1. This mode is suitable for projections on the wall, ceiling or ground without any head movement.

Mod. 2 --- Mode 2. This mode uses all ColorWash 575 AT Zoom functions including pan/tilt movement and therefore is good for a complete introduction of the fixture.

9.8 Stand-alone setting



Use this menu to set options for stand-alone mode as a selection of the playing program, programming and modifying current programs.

Audi --- Music trigger. Select this function to enable the sound control of the running programs via the built-in microphone.

Auto --- Presetting playback. This function allows you to select the program which will be played in the stand-alone mode after switching the fixture on. Selected program will be played continuously in a loop.

d.Abl --- The option disables "Auto" function.

tEST --- The option will start built-in test program.

PrG. 1 --- The option will start created program No. 1

PrG. 2 --- The option will start created program No. 2

PrG. 3 --- The option will start created program No. 3

Note: If the fixture operates in the controller mode (DMX controller is connected) and any program from this menu is selected ,in this case the fixture will not respond to the DMX controller after switching on and will play selected program.

PLAY --- Playing program. Select this menu to run a built-in program or the 3 freely-programmable programs in a loop.

tEST --- The option starts built-in test program.

PrG.1 --- The option starts created program No. 1

PrG.2 --- The option starts created program No. 2

PrG. 2 --- The option starts created program No. 3

Select the program you wish and press [ENTER]. The selected program starts running. By Pressing [ENTER] again is possible to pause the program running.

Edit --- Editing program. Select this menu to edit or create the program. The ColorWash 575 AT Zoom has one built-in program and the 3 free programs, each up to 99 steps. Each program step has a step time. Step time-the time, during which effects last in the current step.

If the fixture is set as a master, then you may edit any program in the slaves. You can't edit programs on the slave fixtures from their control panels if the master fixture is switched on and connected to the slaves (editing is possible by the master control panel only).

Procedure:

1. Press [UP] or [DOWN] to select the program you want to edit ("PrG.1" - "PrG.3") and press [ENTER].
2. Press [UP] or [DOWN] to select the desired fixture ("MASt." - "SLA.9") and press [ENTER]-button.
3. Press [UP] or [DOWN] to select the desired program step ("St.01" - "St.99") and press [ENTER]-button.
4. Press [UP] or [DOWN] to select the desired item and press [ENTER]-button. Now you can edit by [UP] or [DOWN] buttons the DMX value (0-255) for selected item:

P.End. - a total number of the program steps (value 1-99). **This value you must set before start programming** (e.g. if you want to create program with the 10 steps, set P.End=10).

PAn a coarse pan movement

F.PAn a fine pan movement

tilt a coarse tilt movement

SpEd a pan/tilt speed

P.t.SE. a pan/tilt macro selection

MAGE. a magenta lemella

YELL. a yellow lamella

CtC.F. a CTC filter

C.SPd. a CMY/CTC/dimmer speed

Macr. a CMY macros

P.t.SP. a pan/tilt macro speed

Func. a special function

Colo. a colour wheel

CYAN a cyan lamella

S.tim. a step time,value 0,1-25,5 seconds

COPY. - copying the current prog. step to the next prog. step .If the last prog.step is copied to the next prog. step ,parameter "**P.End**" is increased about one by itself (except step 99).

Zoom a zoom

Stro. a shutter,stroke

dimr a dimmer

5. Press [ENTER]-button to confirm adjusted value .

6. Press [MODE]-button,select next prog. step and repeat this procedure (steps 4 - 6).

9.9 Reset function



This option enables the ColorWash 757 AT to index all effects (functions) and return to their standard positions.

9.10 Special functions



Use this menu for special services like adjusting lamp or adjusting effects.

LA.Ad. --- Lamp adjustment. This function can be used when you make the fine adjustment of the lamp.If you select this function,all effects will be canceled,shutter will be opened and the dimmer intensity will be set onto 100%.By using the options "**PAn, tilt,Zoom.**" you can focus the light on a flat surface (wall) and perform the fine lamp adjustment.

Code --- Code. This function contains identification hexadecimal code (0000-FFFF) for the fixture, which is used for the master/slave operation.

AdJ. --- Effect adjustment. By this function you can calibrate and adjust the effects to their standard/right positions.Disconnect the DMX controller from the fixture and select "**AdJ.**" menu.The display shows step by step effects by which you can adjust the fixture to the required position before the function calibration(DMX controller must be disconnected) . When the positioning is finished ,select "**F.CAL.**" and press [ENTER]:

1. Calibration via the control board

Disconnect DMX controller from the fixture.Press [ENTER] and use [UP] and [DOWN] in order to display the following items: "**Colo,Zoom,dimr**" for very smooth function calibration. Select one of them, press [ENTER] and use the [UP] and [DOWN] in order to adjust their right value from 0 to 255. Then press [ENTER] to confirm or [MODE] to cancel and return to the menu. This can be repeated for each calibration parameter if it is required. When the calibration is finished, it is necessary to use the "**A.rES**" function in order to write the calibration values to the memory (EPROM) and to make a reset in order to check the newly adjusted positions of the effects. When the reset of the fixture is finished, the display will show the "**F.CAL**" message. Press [ENTER] to repeat the calibration or [MODE] to return to the "**AdJ.**" menu.

2. Calibration via the external controller

Connect the DMX controller to the fixture, press [ENTER] and the [UP] and [DOWN] buttons in order to display the following items: "**Colo,Zoom,dimr**" . Select one of them and press [ENTER].

Now you can calibrate this effect by your controller. The DMX calibration protocol are described below.

DMX calibration protocol:

| Effect | Mode 1 | Mode 2 | Mode 3 | Mode 4 |
|-----------------------|------------|------------|------------|------------|
| "Colo."- Colour wheel | channel 20 | channel 17 | channel 22 | channel 19 |
| "Zoom" - Zoom | channel 21 | channel 18 | channel 23 | channel 20 |
| "dimr"- Dimmer | channel 22 | channel 19 | channel 24 | channel 21 |

After having calibrated required effects, press [ENTER] to confirm (or [MODE] to cancel and return to the menu without reset by the "**A.rES.**" function) and use the "**A.rES.**" function in order to write the calibration values to the memory (EEPROM) and to make a reset in order to check the new adjusted positions of the effects.

uPd.M. ---Updating mode. Using this function you can update software in the fixture via PC and serial link. The following are required in order to update software:

- PC running Windows 95/98/2000/XP or Linux
- DMX Software Uploader
- Flash Cable RS232/DMX (No.13050624)

Note1: Software update should be executed by a qualified person. If you lack qualification, do not attempt the update yourself and ask for help from your ROBE distributor.

Note 2: DMX address, programs 1-3 and all functions in menu "PErS" will be set to their default values.

To update software in the fixture:

1. Installation of DMX Software Uploader.

1. DMX Software Uploader program is available from the ROBE web site at WWW.robe.cz.
2. Make a new directory (e.g. Robe_Uploader) on your hard disk and download the software to it.
3. Unpack the program from the archive. Program file has name: DSU_name of corresponding fixture_SoftwareID. If the Robe fixture is produced in magnetic and electronic ballast version, the name of DMX Software Uploader is the same for both versions. SoftwareID describes the versions of fixture software included in DMX Software Uploader. Higher number means later software versions.

2. Fixture software updating.

1. Determine which of your COM ports is available on your PC and connect it with to the DMX input of the fixture using the Flash Cable RS232/DMX. Do not extend this cable! Disconnect the fixture from the other fixtures in DMX chain! Turn on the computer and the fixture. Make sure that the lamp is switched off.
2. Switch the fixture to the update mode by selecting the option Updating mode in menu Special Functions on the fixture control panel: SPEC-->UPd-->yES. (From this option you cannot return back to the main menu. If you do not want to continue in software update, you have to switch off and on the fixture to leave this option!)
3. It is recommended that you exit all programs before running the Software Uploader.
4. Start the Software Uploader program. Select desired COM and then click Connect button. If the connection is OK, click Start Uploading button to start uploading. It will take several minutes to perform software update. If the option "Incremental Update" isn't checked, all processors will be updated (including processors with the same software version). If you wish to update only later versions of processors, enable the Incremental Update check box. Avoid interrupting the process. Update status is being displayed in the list window. When the update is finished, the line with the text "The fixture is successfully updated" will appear in this window and the fixture will reset with the new software.

Note: In the case of interruption of the upload process (e.g. power cut), the fixture remains in the update mode and you have to repeat the software update again.

For example: The fixture was switched off before finishing software upload. After switching the fixture on again, the fixture is still in the update mode. Restart the Software Uploader program and repeat software update from your PC.

10. Low power mode

This mode omits fixture reset after switching the fixture on and lowers motor powers of the fixture. "Power down mode" is useful in special cases, e.g. if the fixture is in a flight case and you want to set its DMX address without taking it out from the case. To enter "Power down mode", press and hold [UP] and [DOWN] and at the same time switch on the Power switch. The following message appears on the display: "**P.d.Mo.**"

Press [ENTER] to activate "Low power mode" without fixture reset. Now you can set features and behaviour of the fixture by using "A001" menu and "Pers." menu. If you want to go to the "normal operation mode", execute fixture reset.

Note: All motors (except pan and tilt motors) in "Low power mode" are deactivated and switching on the lamp from the control panel is blocked.

11. Error and information messages

HEAt

This message appears if you try to switch on the lamp within 5 minutes after having switched it off (the lamp is too hot). The message will appear on the display if the lamp doesn't ignite within 28 seconds. The ColorWash 575 AT Zoom will store this information and automatically ignite the lamp when the 5 minutes period has expired.

Caution: The message is disabled if the lamp light sensor (function "En.Sn.") is switched Off (only if the lamp was turned Off and On within 5 minutes, the message "HEAT" will appear).

LA.Er.

The ignition of the lamp is seven times unsuccessful (the "HEAT" message appeared six times before), and the display shows "LA.Er", meaning that the lamp could be damaged or even missed, the fixture is overheating (this can occur if the ambient temperature is 40° C or more) or there could be a failure on the ignitor or ballast. Please place or replace the lamp, check the ambient temperature or contact your dealer if the situation was not caused by the lamp.

Caution: The message is disabled if the lamp light sensor (function "En.Sn.") is switched Off.

Mb.Er.

This message informs you that the main PCB does not communicate correctly with the Control Board.

Co.Er. (color-wheel error)

This message will appear after the reset of the fixture if the magnetic-indexing circuit malfunctions (sensor failed or magnet missing) or the stepping-motor is defective (or its driver circuit on the main PCB). The color-wheel is not located in the default position after the reset.

Ft.Er.

This error message informs you that the fixture was overheating (occured if the ambient temperature is 40° C or more) and that the relay switched off the lamp.

Fr.Er.

This message will appear if the frequency of the main is not standard 50 or 60 Hz. This message can appear as a result of the interference during the lamp starting (if the lamp or igniter is old) or as a result of the interference by neighbouring devices. **In these cases the message does not affect the fixture operating!**

Sn.Er.

This message appears if the lamp lighting sensor is failed.

PoEr

This message will appear if the fixture was shortly disconnect from the main.

Zo.Er. (zoom error)

This message will appear after the reset of the fixture if the magnetic-indexing circuit malfunctions (sensor failed or magnet missing) or the stepping-motor is defective (or its driver circuit on the main PCB). The zoom unit is not located in the default position after the reset.

PA.Er. (Pan-yoke movement error)

This message will appear after the reset of the fixture if the yoke's magnetic-indexing circuits malfunction (sensors failed or magnet missing) or the stepping motor is defective. (Or its driving IC on the main PCB). The yoke is not located in the default position after the reset.

ti.Er. (TILT-head movement error)

This message will appear after the reset of the fixture if the head's magnetic-indexing circuit malfunctions (sensor failed or magnet missing) or the stepping motor is defective. (Or its driving IC on the main PCB). The head is not located in the default position after the reset.

MA.Er.(Master error)

The message informs you that the fixture was addressed as a master and DMX signal is connected to its input. Disconnect the DMX controller from fixture's input and address the fixture as the master again.

t.M.Er.(Temperature measuring error)

The message informs you that the communication between the head and the main board in the fixture base was cut off (or the head temperature sensor is defective) and the lamp was automatically switched off.

12. Technical specifications

Power supply:

EU-model: Voltage:.....208/230/240V AC, 50/60Hz ~
Fuse:.....T 6.3A@230V
US-model: Voltage:.....100/120/208/230V AC, 50/60Hz ~
Fuse:.....T 10A@120V
Power consumption:.....720 VA

Lamp:

Philips MSR 575/2, 95V/575W GX-9,5

Optical System:

- High luminous-efficiency glass reflector
- Front Fresnel lenses of diameter 200 mm
- Internal diffusion lens of diameter 136 mm

Colour wheel:

- 5 replaceable 'SLOT&LOCK' dichroic filters (including 6000 K and UV filter) + open

Strobe:

- Strobe effect with variable speed (max.15 flashes per second)

Dimmer:

- Smooth dimmer from 0 - 100 %

Zoom

- Motorized zoom, angle range depends on the front lens :
Standard front Fresnel lens: 8°-50°
Front wide-angle lens (optional): 87°

CMY-colours mixing module

- Smooth CMY colour mixing system
- Colour temperature correction filter lowers the colour temperature from 7200K to 3200 K
- 30 colour macros

Motors:

- 13 high quality stepping-motors controlled by microprocessors

Electronics:

- Addressing, special functions setting, effects calibration via control panel with 4-digit LED display
- Readout fixture and lamp usage, receiving DMX values, temperature, etc
- Built-in analyzer for easy fault finding, error messages
- Remotely switching on/off the lamp
- Built-in demo sequences
- Black-out while head moving or color changing
- Silent fans cooling,
- Self-resetable thermo-fuse
- Master/slave operation
- Digital serial input DMX-512
- 4 control-channels presettings (16,18,19,21 control channels)

Pan/Tilt

- Pan movement range 530°
- Tilt movement range 280°
- 16 bit movement resolution
- Automatic Pan / Tilt position correction
- Remotely controllable speed of pan/tilt movement for easy programming
- Movement control:tracking and vector

Rigging

- Stands directly on the floor
- Mounts horizontally or vertically with 2 Omega brackets

- 2 truss orientation
- Safety chain/cord attachment point

Temperatures

- Maximum ambient temperature : 40° C
- Maximum housing temperature : 85° C

Minimum distances

- Min.distance from flammable surfaces: 0.7m
- Min.distance to lighted object: 2.0m

Dimensions(mm)

- Dimensions of the fixture:

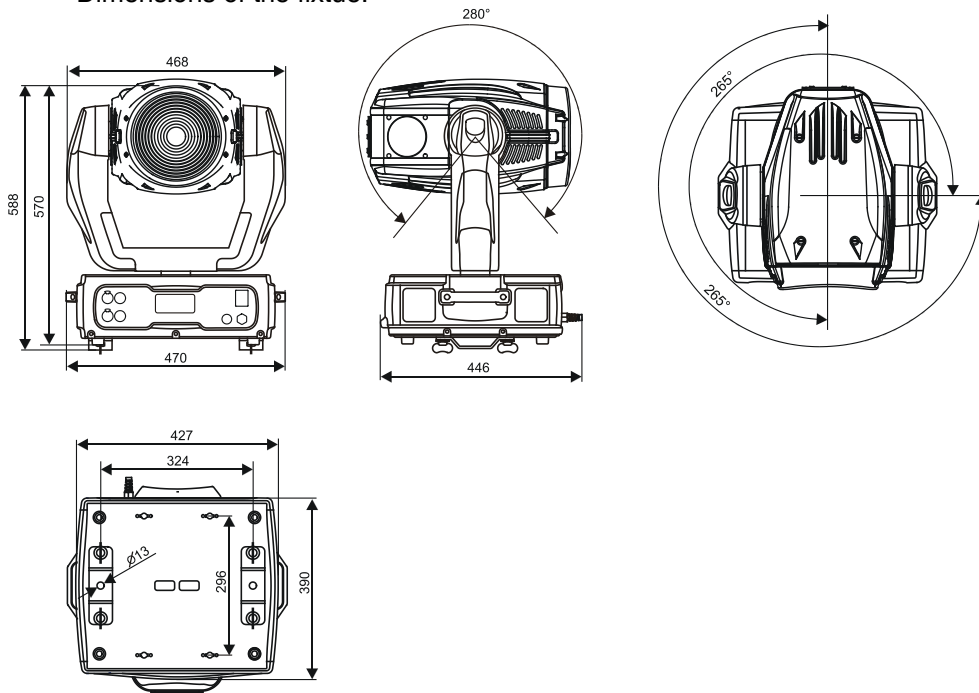

- Dimensions of the optional top hats

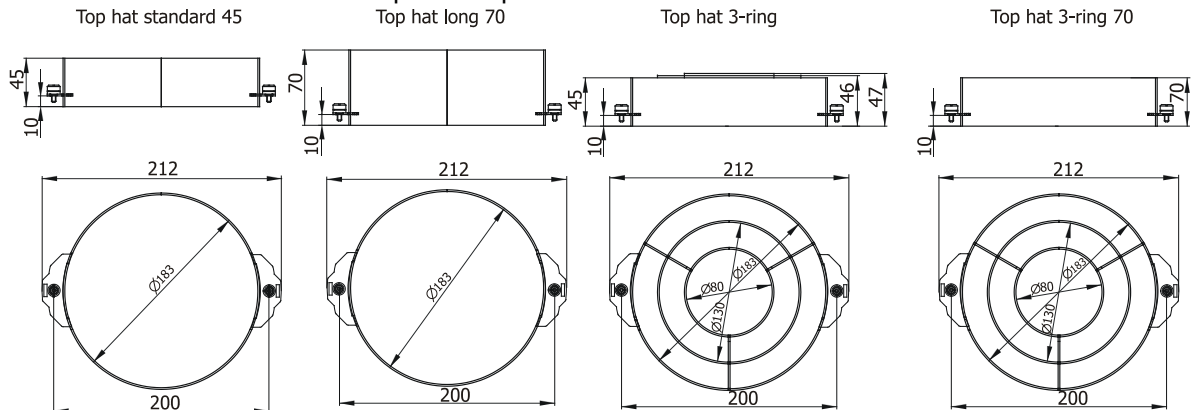

Weight (net):

- EU version:30.5 kg
- US version:34.5 kg

Accessories

- Omega holder (2 pieces).....No.99010420

Optional Accessories

- Flash cable RS232/DMX.....No.13050624
- Module of Front wide-angle lens D200.....No.99011101
- Top hat standard 45No.10980044
- Top hat long 70No.10980045
- Top hat 3-ring 45No.10980046
- Top hat 3-ring 70No.10980050

Beampath (standard Fresnel lens)

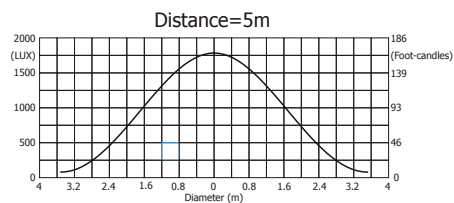
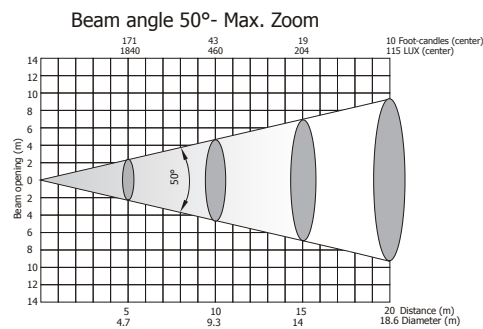
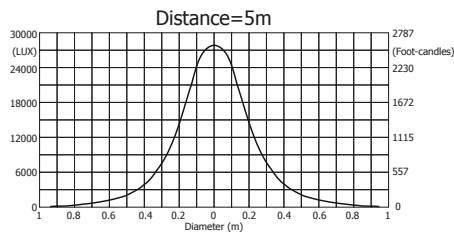
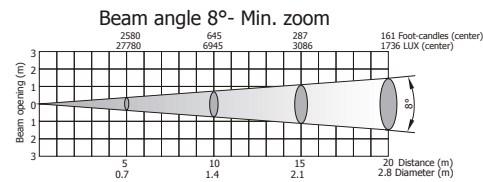

13. Maintenance and cleaning

It is absolutely essential that the fixture is kept clean and that dust, dirt and smoke-fluid residues must not build up on or within the fixture. Otherwise, the fixture's light-output will be significantly reduced. Regular cleaning will not only ensure the maximum light-output, but will also allow the fixture to function reliably throughout its life. A soft lint-free cloth moistened with any good glass cleaning fluid is recommended, under no circumstances should alcohol or solvents be used!

DANGER !
Disconnect from the mains before starting any maintenance work

The front objective lens will require weekly cleaning as smoke-fluid tends to building up residues, reducing the light output very quickly. The cooling fans should be cleaned monthly.

The interior of the fixture should be cleaned at least annually using a vacuum-cleaner or an air-jet.

The dichroic colour filters should be cleaned monthly.

There are no serviceable parts inside the device except for the lamp and the fuse.

Please refer to the instructions under "Fitting/Exchanging the lamp".

Maintenance and service operations are only to be carried out by authorized distributors.

Replacing the fuse

If the lamp burns out, the fine-wire fuse of the device might fuse, too. Only replace the fuse by a fuse of same type and rating.

Before replacing the fuse, unplug mains lead.

Procedure:

- 1) Unscrew the fuseholder on the rear panel of the base with a fitting screwdriver from the housing (anti - clockwise).
- 2) Remove the old fuse from the fuseholder.
- 3) Install the new fuse in the fuseholder.
- 4) Replace the fuseholder in the housing and fix it.

