

*Moving Mirror Luminaire*  
**Scan 250<sup>XT</sup>**

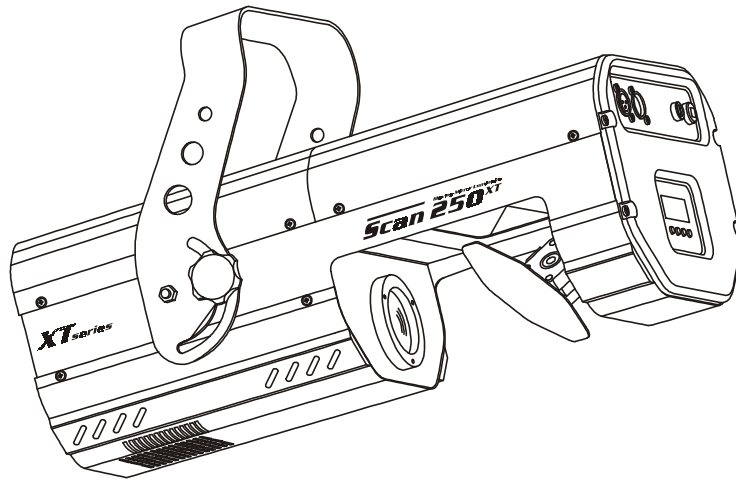

**USER MANUAL**

**XT** series



[www.robe.cz](http://www.robe.cz)





# SCAN 250 XT

## Table of contents

<b>1. Safety instructions</b> .....	<b>4</b>
<b>2. Operating determinations</b> .....	<b>5</b>
<b>3. Description of the device</b> .....	<b>6</b>
<b>4. Installation</b> .....	<b>7</b>
4.1 Fitting the lamp .....	7
4.2 Installation of an optional lens .....	8
4.3 Inserting/Exchanging rotating gobos .....	9
4.4 Rigging the fixture .....	9
4.5 Connection to the mains .....	10
4.6 DMX-512 connection/connection between fixtures .....	10
<b>5. DMX PROTOCOL</b> .....	<b>11</b>
<b>6. Controller mode</b> .....	<b>13</b>
6.1 DMX addressing .....	13
6.2 Remotely controllable functions .....	13
<b>7. Stand - alone mode</b> .....	<b>14</b>
<b>8. Functions of the control panel</b> .....	<b>15</b>
8.1 Addressing .....	15
8.2 Slave control .....	16
8.3 Fixture informations .....	16
8.4 Personality options .....	18
8.5 Switching On/Off the lamp .....	22
8.6 Test sequences .....	22
8.7 Stand-alone setting .....	23
8.8 Reset function .....	24
8.9 Special functions .....	25
<b>9. Error and information messages</b> .....	<b>27</b>
<b>10. Technical specifications</b> .....	<b>28</b>
<b>11. Maintenance and cleaning</b> .....	<b>30</b>
<b>12. Appendix</b> .....	<b>31</b>
12.1 Changing the power supply settings .....	31

**CAUTION!**  
***Keep this device away from rain and moisture!***  
***Unplug mains lead before opening the housing!***

**FOR YOUR OWN SAFETY, PLEASE READ THIS USER MANUAL CAREFULLY  
BEFORE YOU INITIAL START - UP!**

## **1. Safety instructions**

Every person involved with installation and maintenance of this device have to:

- be qualified
- follow the instructions of this manual

**CAUTION!**  
***Be careful with your operations. With a high voltage you can suffer  
a dangerous electric shock when touching the wires!***

This device has left our premises in absolutely perfect condition. In order to maintain this condition and to ensure a safe operation, it is absolutely necessary for the user to follow the safety instructions and warning notes written in this manual.

### **Important:**

The manufacturer will not accept liability for any resulting damages caused by the non-observance of this manual or any unauthorized modification to the device.

Please consider that damages caused by manual modifications to the device are not subject to warranty.

Never let the power-cord come into contact with other cables! Handle the power-cord and all connections with the mains with particular caution!

Always plug in the power plug least. The power-plug has to be accessible after installing the device.

Make sure that the power-cord is never crimped or damaged by sharp edges. Check the device and the power-cord from time to time.

Always disconnect from the mains, when the device is not in use or before cleaning it. Only handle the power-cord by the plug. Never pull out the plug by tugging the power-cord.

This device falls under protection class I. Therefore it is essential to connect the yellow/green conductor to earth.

The electric connection, repairs and servicing must be carried out by a qualified employee.  
Do not connect this device to a dimmer pack.

Do not switch the fixture on and off in short intervals as this would reduce the lamp's life.

During the initial start-up some smoke or smell may arise. This is a normal process and does not necessarily mean that the device is defective.

Do not touch the device's housing bare hands during its operation (housing becomes hot)!  
For replacement use lamps and fuses of same type and rating only.

**CAUTION! EYEDAMAGES!**  
***Avoid looking directly into the light source  
(meant especially for epileptics)!***

## 2. Operating determinations

This device was designed for indoor use only.

If the device has been exposed to drastic temperature fluctuation (e.g. after transportation), do not switch it on immediately. The arising condensation water might damage your device. Leave the device switched off until it has reached room temperature.

When taking the device into operation, please make sure that the housing is closed firmly with all the necessary screws tightened up.

Never run the device without lamp!

Do not shake the device. Avoid brute force when installing or operating the device.

When choosing the installation-spot, please make sure that the device is not exposed to extreme heat, moisture or dust. There should not be any cables lying around. You endanger your own and the safety of others!

The minimum distance between light-output and the illuminated surface must be more than 0,8 m.

Make sure that the area below the installation place is blocked when rigging, derigging or servicing the fixture.

Always fix the fixture with an appropriate safety-rope. Fix the safety-rope at the correct holes only.

Only operate the fixture after having checked that the housing is firmly closed and all screws are tightly fastened.

The lamp must never be ignited if the objective-lens or any housing-cover is open, as discharge lamps may explode and emit a high ultraviolet radiation, which may cause burns.

The maximum ambient temperature  $t_a = 45^\circ \text{C}$  must never be exceeded. Otherwise, the lamp is switched off and the fixture is out of operation for 5 minutes.

**CAUTION!**

***The lens has to be replaced when it is obviously damaged, so that its function is impaired, e. g. due to cracks or deep scratches!***

Operate the device only after having familiarized with its functions. Do not permit operation by persons not qualified for operating the device. Most damages are the result of unprofessional operation!

**CAUTION!**

***The lamp has to be replaced when it is damaged or deformed due to the heat!***

Wait at least 15 minutes before removing the lamp.

Please use the original packaging if the device is to be transported.

Please consider that unauthorized modifications on the device are forbidden due to safety reasons!

If this device will be operated in any way different to the one described in this manual, the product may suffer damages and the guarantee becomes void. Furthermore, any other operation may lead to dangers like short-circuit, burns, electric shock, burns due to ultraviolet radiation, lamp explosion, crash etc.

### 3. Description of the device

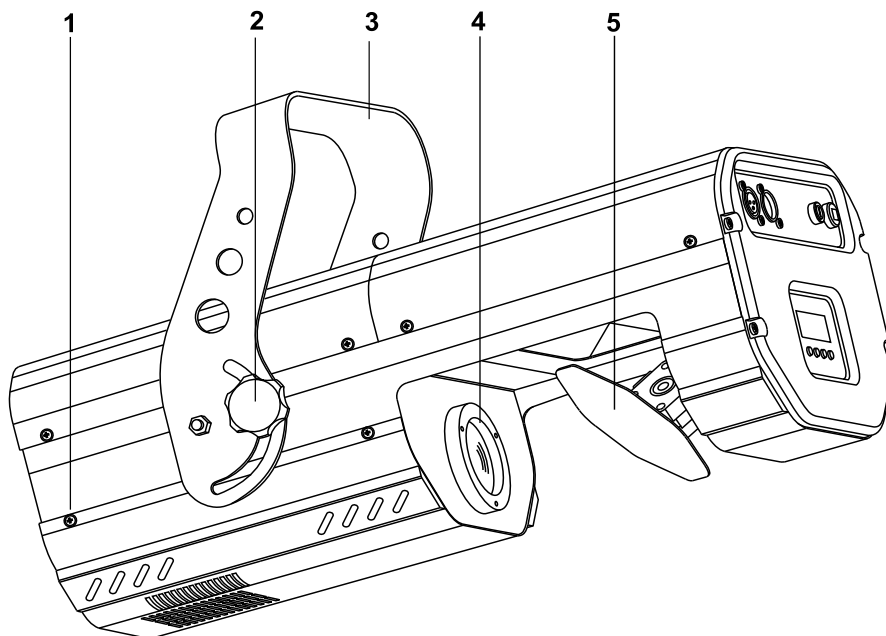

- 1 - Fastening screws
- 2 - Fixation screw for bracket
- 3 - Bracket
- 4 - Objective
- 5 - Mirror

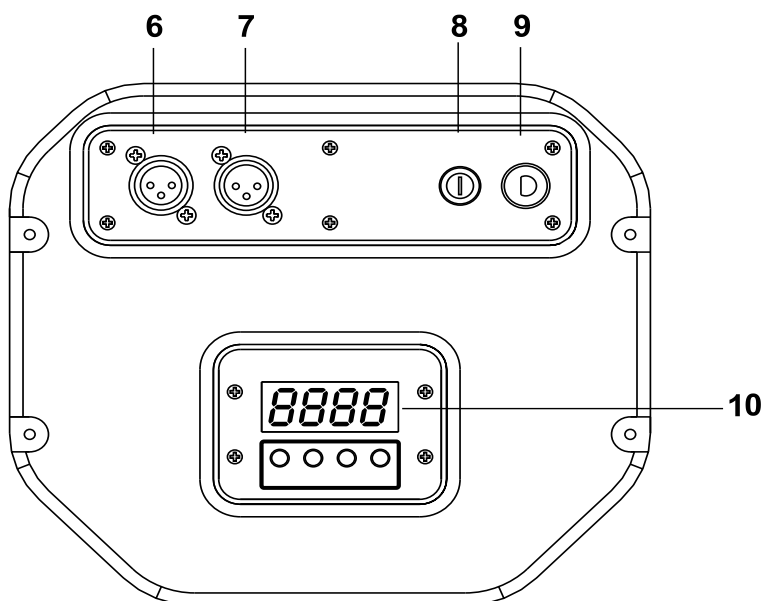

- Front panel:**
- 6 - DMX Output
  - 7 - DMX Input
  - 8 - Fuseholder
  - 9 - Powercord
  - 10 - Control board

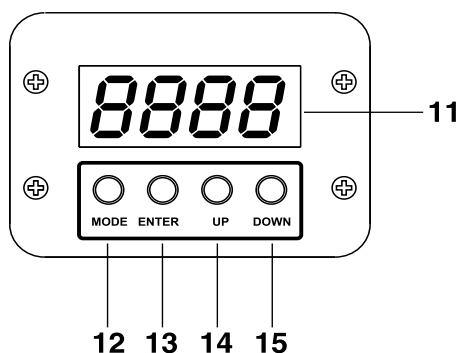

- Control board:**
- 11 - Display
  - 12 - Mode-button
  - 13 - Enter-button
  - 14 - Up-button
  - 15 - Down-button

## 4. Installation

### 4.1 Fitting the lamp

**DANGER!**  
**Install the lamps with the device switched off only.**  
**Unplug from mains before !**

To insert the lamp (MSD 250 or MSD250/2) open the cover by loosening the fastening screws at the sides of the cover.

Do not install a lamp with a higher wattage! A lamp like this generates temperatures the device is not designed for. Damages caused by non-observance are not subject to warranty.

Insert the lamp now. Do not touch the glass bulb with bare hands during the installation! Please follow the lamp manufacturer's notes!

Before you close the cover again, make sure that the lamp is installed tightly into the lampholder system.

Adjust the optimal distance 1-1.5 mm from the lens by turning the screw "A" (see the drawings "Lamp adjustment" below) on the rear panel of the fixture.

Reclose the housing and tighten the fastening screws.

Before striking the lamp, reset the "LAti" counter in the main menu of the control board, by pressing the "Up" and "Down" buttons at the same time and then confirming with the "Enter"-button.

**Do not operate this fixture with opened housing-cover!**

#### Lamp adjustment:

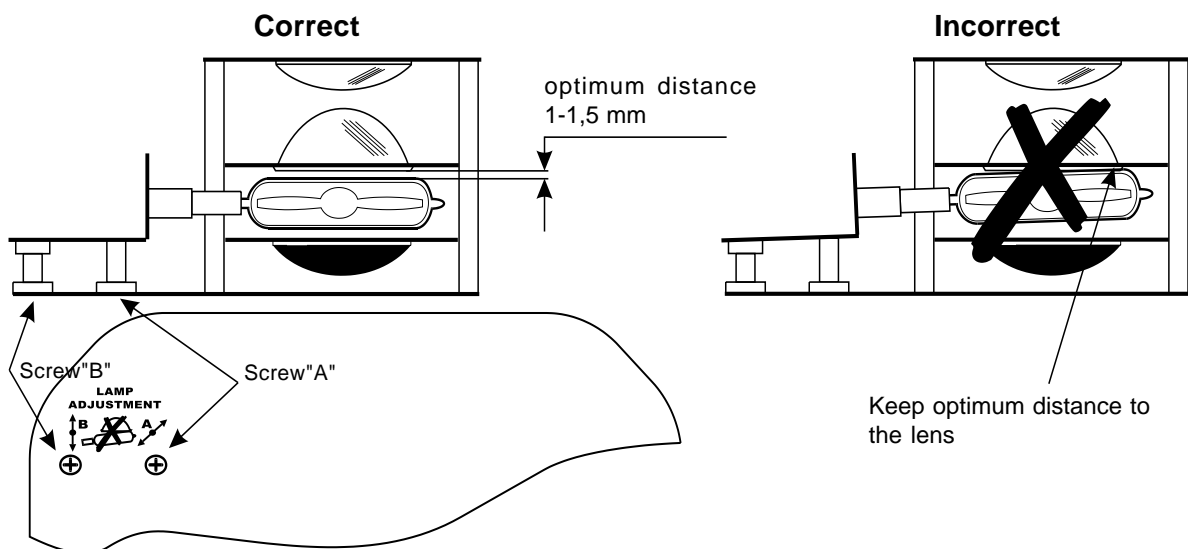

The lampholder is aligned at the factory. Due to differences between lamps, fine adjustment may improve light performance.

Strike the lamp, cancel all effects, open the shutter and set the dimmer intensity onto 100 % and focus the light on a flat surface (wall). As the optimum distance of the lamp from lens was adjusted during the installing or changing the lamp (by turning the screw "A"), it is necessary to adjust only the second position by turning the screw "B", in order to center the hot-spot (the brightest part of the beam).

If the hot spot seems to be too bright, you can lower its intensity by moving the lamp closer to the reflector. Do so by turning the screw "A" until the light is evenly distributed.

If the light on the edge seems to be brighter as in the center, the lamp is too close at the reflector. In this case, you need to move the lamp away from the reflector until the light is evenly distributed and the beam appears bright enough.

## 4.2 Installation of an optional lens

The device is delivered with a 15°-standard lens. If you wish to insert an optional 12° or 18°-lens (it is not standard part of delivery, only for request), please follow the instructions below:

### Optional 12°-lens:

Remove the the 15°-objective by loosening the 3 fastening screws with an appropriate screwdriver. Fix the tube with the 3 screws and then screw the flange with 12°-lens .

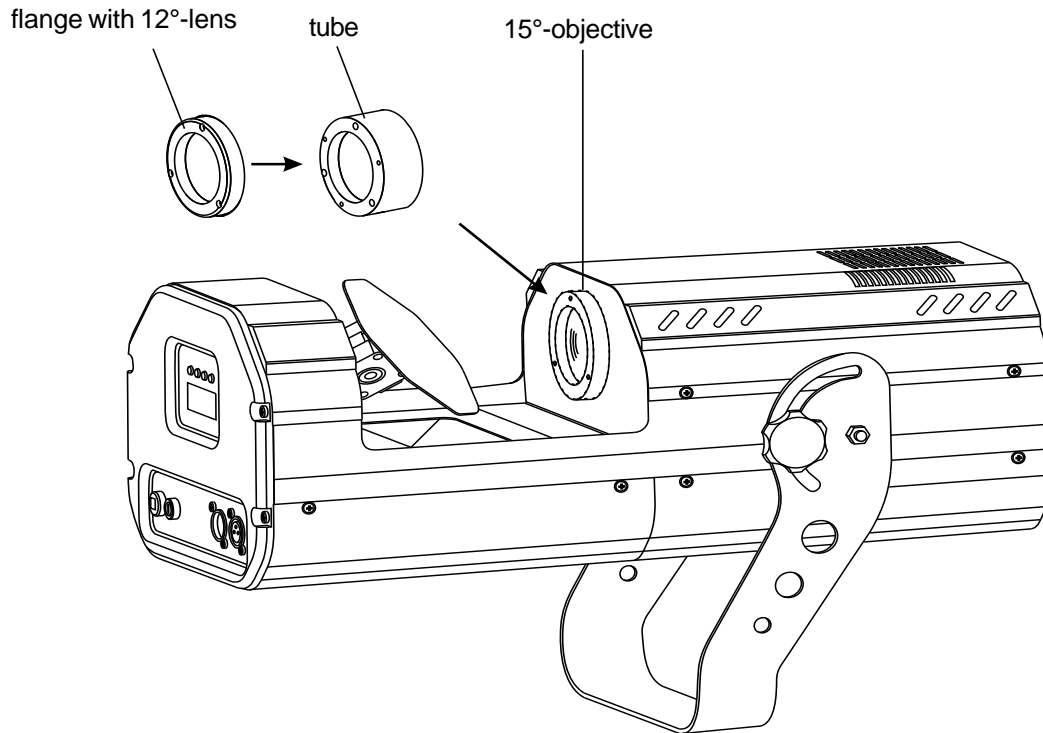

### Optional 18°-lens:

1. Open the cover by loosening the fastening screws at the sides of the cover. Unscrew the knurled-head screw on the plate of the light-output. Install the optional 18°-lens module.
2. Fix the 18°-lens module with the knurled-head screw. Close the cover and tighten the fastening screws at the sides of the cover.

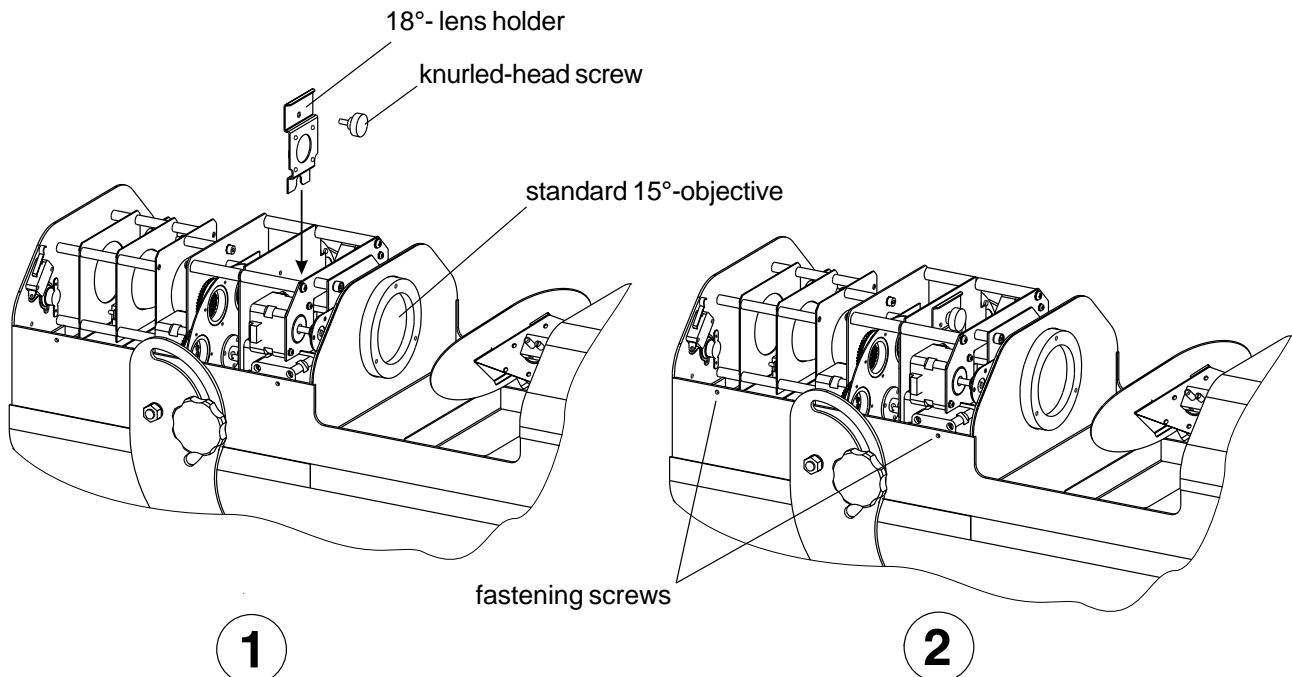



### 4.3 Inserting/Exchanging rotating gobos

**DANGER!**  
*Install the gobos with the device switched off only.  
Unplug from mains before!*

Open the cover by loosening the fastening screws at the sides of the cover.  
If you wish to use other forms and patterns as the standard-gobos, or if the gobos are to be exchanged, remove the fixation-ring with an appropriate tool. Remove the gobo and insert the new gobo. Press the fixation-ring together and insert it in the front of the gobo.

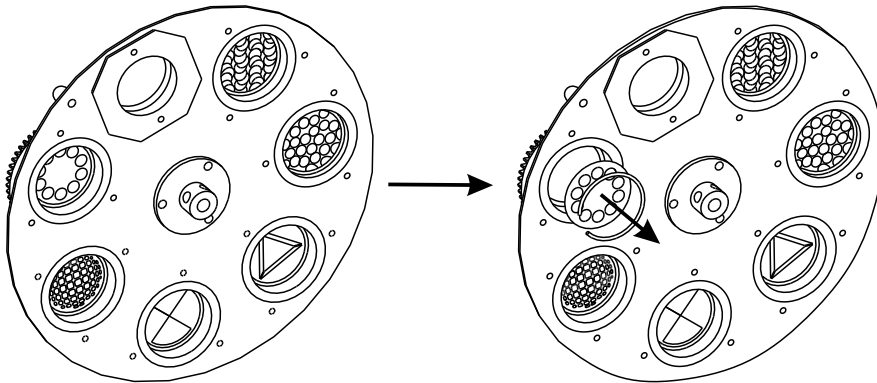

**CAUTION!**  
*Never unscrew the screws of the rotating gobo  
as the ball bearing will otherwise be opened!*

### 4.4 Rigging the fixture

**Danger of fire !**  
*When installing the device, make sure there is no highly inflammable  
material (decoration articles, etc.) in between a distance of min. 0,5 m.*

The SCAN 250 XT can be installed in any position without altering its operation characteristics  
Install a safety wire that can hold at least 10 times the weight of the fixture. Never use the carrying handles for secondary attachment.

**Make sure that the device is fixed properly! Ensure that the structure  
to which you are attaching the projectors is secure.**

For fixing the projectors use the hole provided in the bracket. The hole in the adjustable mounting bracket has a diameter of 10 mm.

For overhead use, fit a safety chain or cord.

## 4.5 Connection to the mains

**Verify the power supply settings before applying power!**

If you wish to change the power supply settings, see the chapter Appendix. Connect the fixture to the mains with the enclosed power cord and plug. The earth has to be connected!

The occupation of the connection-cables is as follows:

Cable (EU)	Cable (US)	Pin	International
Brown	Black	Live	L
Light blue	White	Neutral	N
Yellow/Green	Green	Earth	

## 4.6 DMX-512 connection/connection between fixtures

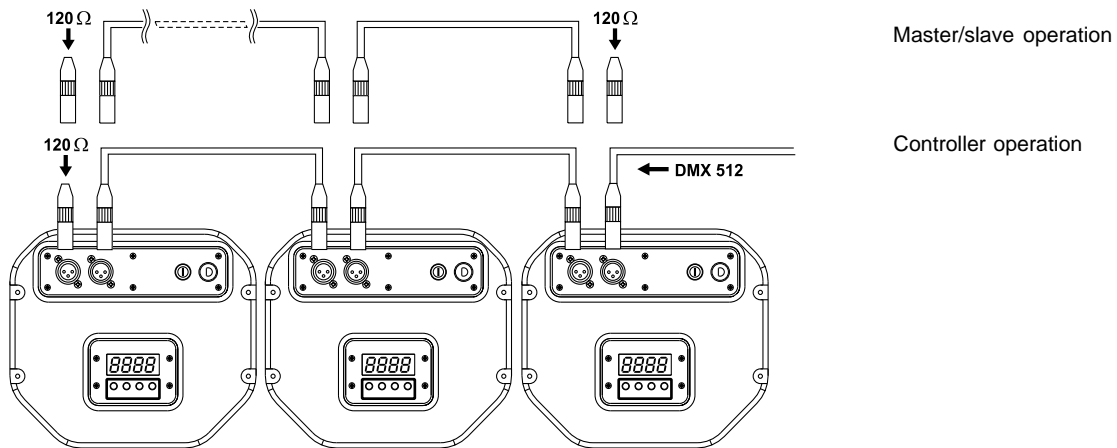

Only use a stereo shielded cable and 3-pin XLR-plugs and connectors in order to connect the controller with the fixture or one fixture with another.

Occupation of the XLR-connection:

**DMX - output**  
XLR mounting-socket:

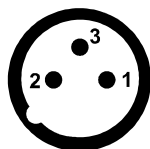

1 - Ground  
2 - Signal (-)  
3 - Signal (+)

**DMX-input**  
XLR mounting-plug:

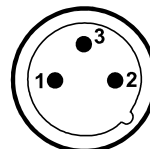

1 - Ground  
2 - Signal (-)  
3 - Signal (+)

If you are using the standard DMX-controllers, you can connect the DMX-output of the controller directly with the DMX-input of the first fixture in the DMX-chain. If you wish to connect DMX-controllers with other XLR-outputs, you need to use adapter-cables.

**Building a serial DMX-chain:**

Connect the DMX-output of the first fixture in the DMX-chain with the DMX-input of the next fixture. Always connect one output with the input of the next fixture until all fixtures are connected.

**Caution:** At the last fixture, the DMX-cable has to be terminated with a terminator. Solder a 120 W resistor between Signal (-) and Signal (+) into a 3-pin XLR-plug and plug it in the DMX-output of the last fixture.

## 5. DMX PROTOCOL

Mode 1 channel	Mode 2 channel	8bit channel	Value	Function	Type of control
1	1	1	0-255	<b>Pan</b> Coarse control of the pan movement	proportional
2	3	2	0-255	<b>Tilt</b> Coarse control of the tilt movement	proportional
3	2		0-255	<b>Pan fine</b> Fine control of the pan movement	proportional
4	4		0-255	<b>Tilt fine</b> Fine control of the tilt movement	proportional
5	5	3	0 249 250-255	<b>Speed of PAN/TILT movement</b> Max. speed Min. speed Max. speed, black-out while PAN, TILT moving	step proportional step
6	6	4	0-127 128-139 140-229 230-239 240-255	<b>Lamp on/off, reset, fan speed control</b> From max. speed of fan to min. speed of fan Lamp on, reset No function Lamp off after 3 sec No function	proportional step step step step
7	7	5	0 10 21 32 42 53 64 74 85 96 106 117 128-190 191-192 193-255	<b>Colours</b> Open/white Turquoise Red Cyan Green Magenta Light blue Yellow Green Pink Blue Orange Forwards rainbow effect from fast to slow No rotation Backwards rainbow effect from slow to fast	proportional proportional proportional proportional proportional proportional proportional proportional proportional proportional proportional proportional proportional step proportional
8	8	6		<b>No function</b>	
9	9	7	0-95 96-103 104-135 136-143 144-151 152-159 160-255 160-167 168-175 176-183 184-191 192-199	<b>Frost, cor. filters, 3-facet prism</b> Open position (hole) Frost filter 3-facet prism 3200 K correction filter 5600 K correction filter UV filter <b>Prism/gobo macros</b> Macro 1 Macro 2 Macro 3 Macro 4 Macro 5	step step step step step step step step step step step

Mode 1 channel	Mode 2 channel	8 bit channel	Value	Function	Type of control
9	9	7	200-207 208-215 216-223 224-231 232-239 240-247 248-255	Macro 6 Macro 7 Macro 8 Macro 9 Macro 10 Macro 11 Macro 12	step step step step step step step
10	10	8	0 1-126 127-128 129-255	<b>3-facet prism rotation control</b> No rotation Forwards rotation from fast to slow No rotation Backwards rotation from slow to fast	step proportional step proportional
11	11	9	0-31 32-63 64-95 96-127 128-159 160-191 192-223 224-255	<b>Rotating gobos,cont.rotation</b> Open Rot. gobo 1 (dichroic) Rot. gobo 2 (glass) Rot. gobo 3 (metal) Rot. gobo 4 (metal) Rot.gobo 5 (metal) Rot.gobo 6 (metal) Rot. gobo wheel cont. rotation from slow to fast	step step step step step step step proportional
12	12	10	0-127 128-191 192 193-255	<b>Rotating gobo index,rotating gobo rotation</b> Gobo indexing Forwards gobo rotation from fast to slow No rotation Backwards gobo rotation from slow to fast	proportional proportional step proportional
13	13	11		<b>No function</b>	
14	14	12	0-255	<b>Focus</b> Proportional focus control	proportional
15	15	13	0-31 32-63 64-95 96-127 128-159 160-191 192-223 224-255	<b>Shutter,stroke</b> Shutter closed No function (shutter open) Strobe-effect from slow to fast (max.10 flashes/s) No function (shutter open) Pulse-effect in sequences No function (shutter open) Random strobe-effect from slow to fast No function (shutter open)	step step proportional step proportional step proportional step
16	16	14	0-255	<b>Dimmer intensity</b> Gradual adjustment of the dimmer intensity from 0 to 100%	proportional

## 6. Controller mode

The fixtures are individually addressed (001-497) on a data link and connected to the controller. The fixtures respond to the DMX signal from the controller.

### 6.1 DMX addressing

The control panel allows you to assign the DMX fixture address, which is defined as the first channel from which the SCAN 250 XT will respond to the controller.

If you set, for example, the address to channel 5, the SCAN 250 XT will use the channel 5 to 20 for control.

Please, be sure that you don't have any overlapping channels in order to control each SCAN 250 XT correctly and independently from any other fixture on the DMX data link.

If two, three or more SCAN 250 XT are addressed similarly, they will work similarly.

For address setting, please refer to the instructions under "Addressing" (menu "A001").

#### Controlling:

After having addressed all SCAN 250 XT, you may now start operating these via your lighting controller.

**Note:** After switching on, the SCAN 250 XT will automatically detect whether DMX 512 data is received or not. If there is no data received at the DMX-input, the display will start to flash "A001" with actually set address.

This situation can occur if:

- the 3 PIN XLR plug (cable with DMX signal from controller) is not connected with the input of the SCAN 250 XT
- the controller is switched off or defective, the cable or connector is defective or the signal wires are swapped in the input connector.

**Note:** It's necessary to insert the XLR termination plug (with 120 Ohm) to the last fixture in the link in order to ensure proper transmission on the DMX data link.

### 6.2 Remotely controllable functions

#### Lamp

The SCAN 250 XT is to be operated with a MSD/HSD 250 or MSD 250/2 GY-9,5 lamp.

A relay inside of the SCAN 250 XT allows you to switch on and off the lamp via the control panel on the top side of the base or via your controller without affecting the rest of the lighting.

To switch On/Off the lamp, please refer to "Switching On/Off the lamp" (menu "LAMP").

**Note:** It is also important to note, that the discharge lamp is cold restrike types, that means, that they have to be cold before re-striking. For this reason, you have to wait 5 minutes (max. speed of fan must be adjusted) after having switched Off the lamp before you can switch it back On again. If you try to switch On the lamp within 5 minutes after having switched it Off, the SCAN 250 XT will store this information and automatically ignite the lamp when the 5 minutes period has expired. The message "HEAT" will appear on the control panel display of the SCAN 250 XT. If the ignition of the lamp is seven times unsuccessful, on the display will appear "LA.Er.", meaning that the lamp could be damaged or even missed, or there could be a failure on the ignitor or ballast.

#### Colour wheel

The SCAN 250 XT has one colour wheel with 12 color positions - 11 of these with dichroic colors and the last one open. The wheel can be positioned between two adjacent colors in any position. It is also possible to rotate the color wheel continuously at different speed „Rainbow effect“.

#### Rotating gobo wheel

1 metal gobo, 4 glass gobos and 1 dichroic gobo rotating in both directions, indexable, rotating gobo wheel cont. rotations from slow to fast. The rotating gobos are interchangeable.

#### Effect wheel

This wheel has both hot and cold colour temperature filters (3200 K and 5600 K). Total numbers of colour combinations are 36. Also wash light and UV effect are provided by the special effect wheel.

#### 3-facet rotating prism

3-facet prism rotating in both directions at different speed is situated at the special effect wheel.

## Focus

Motorized focus enables the beam to be focused anywhere on stage.

## Dimmer / Shutter / Strobe

Smooth 0 - 100 % dimming is provided by the combined mechanical dimmer / shutter unit. This unit may also be used for strobe effect (1 - 10 flashes per second)

## Fan

The SCAN 250 XT is cooled by axial fan situated at the rear side of the lighting. The speed of the fan (of course the noise) can be continuously reduced if very quiet performance is required.

By the control board using the "**FAn.S.**" function you can choose 5 types of fan speed operating modes.

## 7.Stand - alone mode

The fixtures on a data link are not connected to the controller but can execute pre-set programs which can be different for every fixture. To set the program to be played, see the "Stand-alone setting" ( menu "**St.AL.**").

"Stand-alone operation" can be applied to the single fixture (the fixture may be set to the master /slave mode or controller mode ) or to multiple fixtures operating synchronously.

Synchronous operation of multiple fixtures requires that they must be connected on a data link and one of them is set as a master (master mode) and the rest as the slaves (slave mode). The slaves are assigned to SLA.1- SLA.9 and on the certain slave address can be connected only one fixture. To set the fixture as the master or slave , see the "Addressing" (menu "**A001**").

The master fixture starts simultaneous program start in the other slave fixtures. All fixtures have a definite, synchronized starting point when playing back their programs. The number of running program is the same in all slaves and depends on the master's choice (menu "**St.AL.**"). Every fixture runs its program repeatedly ,starting the program step No.1 when requested by the master .

For example:

If the slave fixture has a shorter program length, it will continuously repeat its program until the master fixture finishes its own program and restarts its program running (slave 1- prog.step 3 will not be finished).

If the slave fixture has a longer program length, it will restart at prog. step 1 before it completes all its prog.steps (slave 2 - prog.step 5 will not be played)- see the picture below.

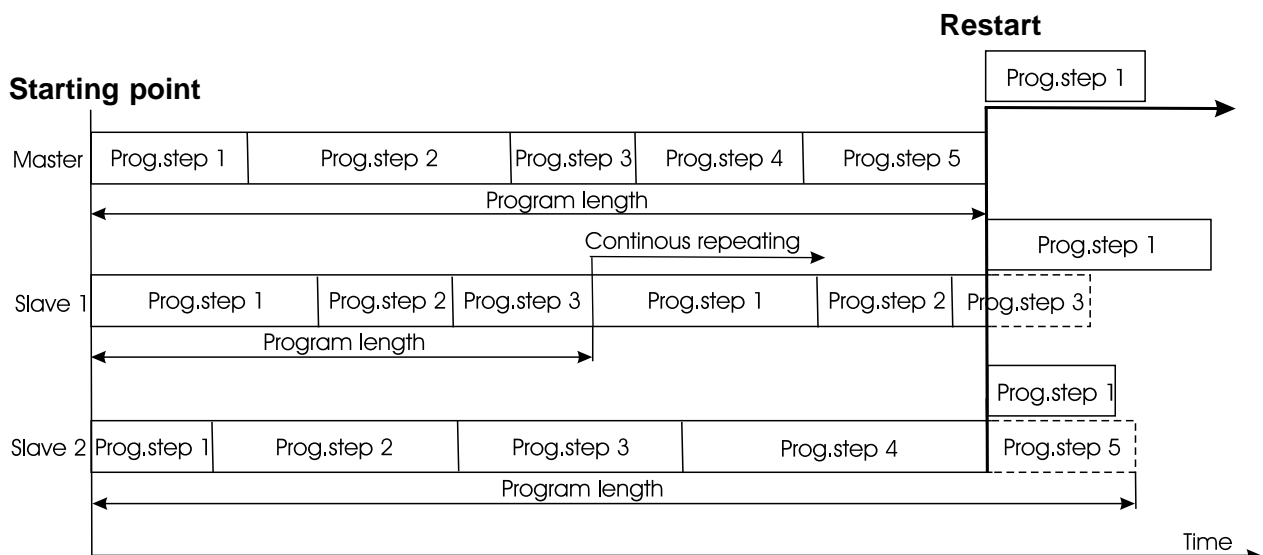

**If the master fixture runs a reset, switches On/Off the lamp or plays test(program) ,all slaves will execute these acts too (e.g. if the master fixture has switched the lamp off, no slaves can switch the lamp on)! You can't play or edit any programs on the slaves by their control panels if the master is switched on and connected to the master/slave chain.**

**Note:** Disconnect the fixtures from the DMX controller before master/slave operating ,otherwise data collisions can occur and the fixtures will not work properly!

It's necessary to insert the XLR termination plug (with 120 Ohm) into the input of the master fixture and into the output of the last slave fixture in the link in order to ensure proper transmission on the data link.

From the master's control panel is possible to control any slave in a master/slave chain.

## 8. Functions of the control panel

The control panel situated on the front side of the fixture offers several features. You can simply set the DMX address, master/slave mode, read the number of lamp or unit hours, switch On and Off the lamp, run test, make a reset and also use many functions for setting and service purposes.

The main menu of the control panel is accessed by pressing the **[Mode]** button - press this one so many times until the display shows message "A001" (with actually stored address). Browse through the menu by the pressing **[Up]** or **[Down]** buttons - the display shows step by step these messages: **A001, SLct, InFO, PErS, LAMP, tESt, StAL, rESE, SPEC.** Press **[Enter]** if you wish to select one of them. The functions are described in the following sections and the function hierarchy is shown below.

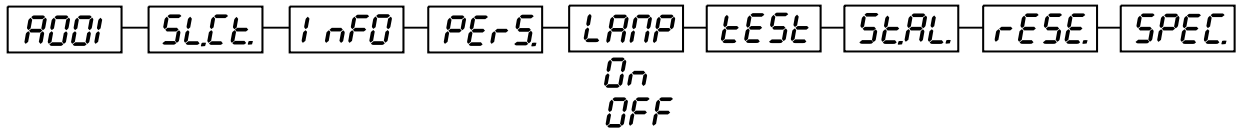

### 8.1 Addressing



By this menu you can set the DMX address or address the fixture as a master/slave.

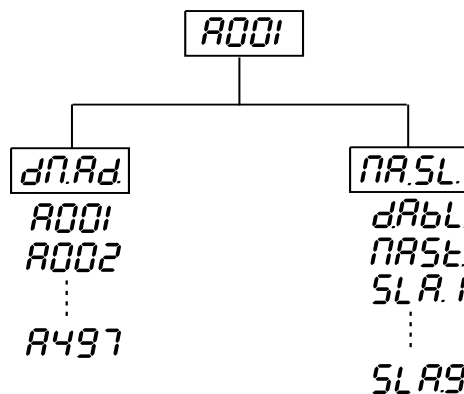

1. Press the **[Mode]**- button so many times until the display shows message "A001" (with actually stored address).
  2. Press **[Enter]**-button and use the **[Up]** and **[down]** buttons to select "dM.Ad."-menu.
  3. Press **[Enter]**-button (the letter "A" flashes) and by **[Up]** and **[down]** buttons select required address (001 - 497), press **[Enter]**-button to confirm.
  4. Select "M.ASL."-menu, press **[Enter]**-button and use **[Up]** and **[down]** buttons to select "d.AbL." (no master or slave), press **[Enter]** to confirm.
  5. Press the **[Mode]**- button. Chosen address is shown on the display.
- If message "A001" (with actually stored address) flashes - no DMX data received at the DMX-input.



1. Press the **[Mode]** button so many times until the display shows message "A001" (with actually stored address).
  2. Press **[Enter]**-button and use the **[Up]** and **[down]** buttons to select "MA.SL."-menu.
  3. Press **[Enter]**-button (display flashes) and select "MASt" (to set the fixture as the master in a chain of multiple fixtures) or "SLA.1" - "SLA.9" (to set the fixture to be the slave in a chain of multiple fixtures) and press **[Enter]** to confirm. If you want address no master or slave, select "d.AbL.".
  4. Press the **[Mode]**- button. Chosen address is shown on the display.
- If message "MASt." fast flashes - DMX signal is received at the DMX-input - disconnect DMX controller!

**Only one fixture may be the master.** Up to the 9 slaves may be connected to the master and on the certain address can be connected only one slave fixture (SLA1-SLA9).

**Note:** Disconnect the fixtures from the DMX controller before master/slave operating ,otherwise data collisions can occur and the fixtures will not work properly!

If the fixture is set as the master and DMX signal is connected to its input,the error message "MAEr" will appear on its display and the fixture's address will be set to its DMX address in order to respond to DMX signal from the controller.

For example:

The master fixture has these address setting:"dM.Ad."-menu.....**A017**

"MA.SL."-menu.....**MASt** (is displayed)

## 8.2 Slave control



This function allows you to control the slaves from the master's control panel in a master/slave operation.

Select this function from the main menu and press **[Enter]**-button.Browse the list of all connected slaves ("SL.C.1" - "SL.C.9") by pressing **[Up]** or **[Down]** button.Select the desired slave and press **[Enter]**-button.The slave's control panel is available from the master's control panel.

If no slave is connected to the master,messages "SL.C.1", "SL.C.2", "SL.C3"... "SL.C.9" still round repeat.

**Note:**This function is available from the master fixture only.

## 8.3 Fixture informations



The menu allows you to read an useful information about the fixture as the lamp life,head temperature,software version, etc.

Press **[Up]** and **[Down]** buttons to select the desired option and press **[Enter]** to see the value or next submenu.

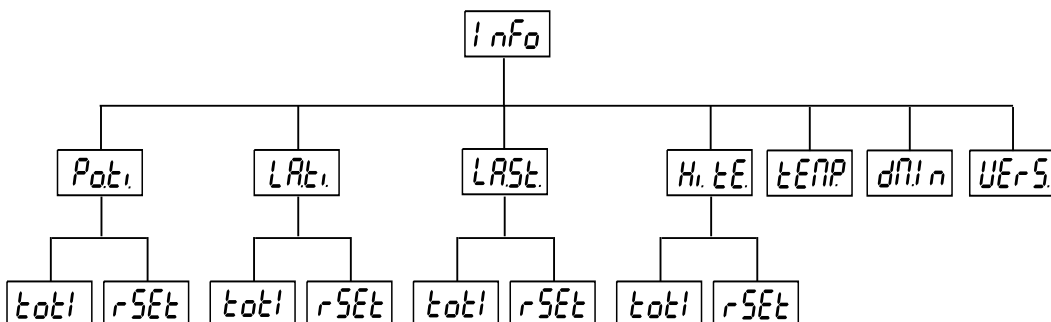

**Power On time**



-By this option you can read the total number of the operation hours since the

SCAN 250 XT has been fabricated. Press **[Enter]** or **[Mode]** to return to the menu.



**rSEt** - The number of the hours that the SCAN 250 XT has been powered On since the counter was last reset. Press **[Enter]** or **[Mode]** to return to the menu. In order to reset this counter to 0, you have to hold the **[Up]** and **[Down]**-button and press the **[Enter]**-button.

**LAt.** **Lamp On time**

**totl** - This option enables you to read the total number of the operation hours with the lamp on since the SCAN 250 XT has been fabricated. Press **[Enter]** or **[Mode]** to return to the menu.

**rSEt** - The number of hours that the lamp has been powered On since the counter was last reset. Press **[Enter]** or **[Mode]** to return to the menu. In order to reset this counter to 0, you have to hold the **[Up]** and **[Down]**-button and press the **[Enter]**-button.

**LASt.** **Lamp strikes**

**totl** - By this option you can read the total number of the lamp strikes since the SCAN 250 XT has been fabricated. Press **[Enter]** or **[Mode]** to return to the menu.

**rSEt** - The number of the lamp strikes since the counter was last reset. Press **[Enter]** or **[Mode]** to return to the menu. In order to reset the counter to 0, you have to hold the **[Up]** and **[Down]**-button and press the **[Enter]**-button.

**Hi. tE.** **Max. fixture head temperature**

**totl** - By this option you can read the max. temperature of the head inside since the SCAN 250 XT has been fabricated. Press **[Enter]** or **[Mode]** to return to the menu.

**rSEt** - Max. temperature of the head inside since the counter was last reset. Press **[Enter]** or **[Mode]** to return to the menu. In order to reset the counter to 0, you have to hold the **[Up]** and **[Down]**-button and press the **[Enter]**-button.

**tEMP.** **Current fixture head temperature**

Temperature readouts of the head inside in Celsius. Inside temperatures below 60°C are not critical. 60° C and more lead to the lamp being switched off. Please note that the outside temperature should not exceed 45° C.

**dMIn.** **DMX values**

Readout DMX values of each channel received by the fixture. Use the **[Up]** and **[Down]** buttons to select desired channel and press **[Enter]** to read its value coming to the fixture or **[Mode]** to cancel and return to the menu.

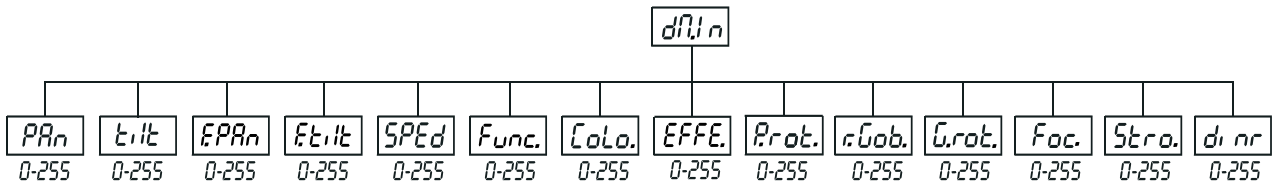

**Ue-r-5.** Software version

By this function you can read the software version of the display module. Press **[Enter]** to read its value or **[Mode]** to return to the menu.

## 8.4 Personality options

**PE-r-5.**

These options allow you to modify SCAN 250 XT operating behavior. Press **[Up]** and **[Down]** buttons to select the desired option and press **[Enter]** to set the value or to see next submenu.

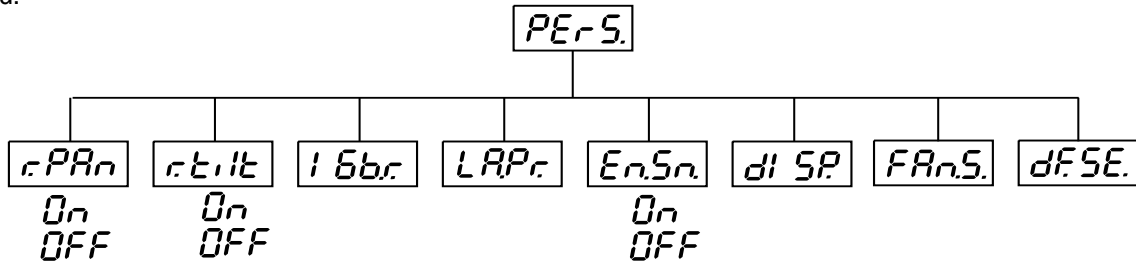

**r.PAn** Pan reverse

This function allows you to invert the pan movement. Use the **[Up]** and **[Down]** buttons to select "On" if you wish this feature or "Off" if you don't wish this feature and press **[Enter]** to confirm or **[Mode]** to cancel and return to the menu.

**r.tilt** Tilt reverse

This function allows you to invert the tilt movement. Use the **[Up]** and **[Down]** buttons to select "On" if you wish this feature or "Off" if you don't wish this feature and press **[Enter]** to confirm or **[Mode]** to cancel and return to the menu.

**16b.r.** Movement resolution

By this function you can adjust the 16-bit movement resolution (Mod.1, Mod. 2) or 8-bit resolution (8bit). Use the **[Up]** or **[Down]** keys to select the desired movement resolution and press **[Enter]** to confirm or **[Mode]** to cancel and return to the menu.

List of the channel settings:

Channel	Mode 1-16bit (default)	Mode 2-16bit	8 bit
1	Pan	Pan	Pan
2	Tilt	Fine Pan	Tilt
3	Fine Pan	Tilt	Pan/Tilt speed
4	Fine Tilt	Fine Tilt	Fans,Lamp On/Off
5	Pan/Tilt speed	Pan/Tilt speed	Colours
6	Fans, On/Off lamp	Fans, On/Off lamp	No function
7	Colours	Colours	Prism
8	No function	No function	Prism rotation
9	Prism	Prism	Rotating gobos
10	Prism rotation	Prism rotation	Gobo rotation
11	Rotating gobos	Rotating gobos	No function
12	Rot.gobo rotation	Rot.gobo rotation	Focus
13	No function	No function	Shutter,Strobe
14	Focus	Focus	Dimmer
15	Shutter, strobe	Shutter, strobe	
16	Dimmer	Dimmer	

Please refer to the chapter "DMX- protocol" for detail description.

**Note:** If you adjust the 16 bit resolution (Mode 1 or Mode 2), the fixture will occupy 16 DMX channels, if you adjust the 8 bit resolution, the fixture will be operated by only 14 DMX channels.

### **L.A.P.r.** Lamp presetting

This function allows you to adjust the lamp settings:

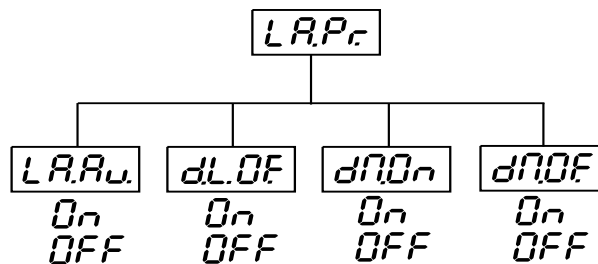

### **L.A.R.u.** Lamp On after switching the fixture On

This function enables to turn the lamp on automatically after switching the fixture on. Use the **[Up]** and **[Down]** buttons to select "On" if you wish to turn the lamp on automatically after switching the fixture on or "Off" if you wish the lamp off after switching on the fixture and press **[Enter]** to confirm or **[Mode]** to cancel and return to the menu.

### **dL.OF.** Lamp Off via DMX

This function allows you to switch off the lamp by DMX. Use the **[Up]** and **[Down]** buttons to select "On" if you want to switch off the lamp by DMX or "Off" if you don't want to switch off the lamp by DMX and press **[Enter]** to confirm or **[Mode]** to cancel and return to the menu.

### **dN.On** Lamp On if DMX is present

This function allows you to strike the lamp automatically after 26 seconds if DMX signal is present on the data link. If the ignition is unsuccessful (e.g. lamp is too hot), the fixture will try to ignite the lamp after next 26 s. This process will repeat until the lamp lights. Use the **[Up]** and **[Down]** buttons to select "On" if you want to strike the lamp or "Off" if you don't want to strike the lamp and press **[Enter]** to confirm or **[Mode]** to cancel and return to the menu.

## **dm.OF.** Lamp Off if DMX is missing

This function allows you to switch Off the lamp automatically after 2 minutes if DMX signal is missing on the data link. Use the **[Up]** and **[Down]** buttons to select "On" if you want to switch Off the lamp or "Off" if you don't want to switch Off the lamp and press **[Enter]** to confirm or **[Mode]** to cancel and return to the menu.

## **En.Sn.** Switch On/Off the lamp light sensor

Use the **[Up]** and **[Down]** buttons to select "On" if you wish to switch the lamp light sensor on and press **[Enter]** to confirm or **[Mode]** to cancel and return to the menu. **The option "On" is for the standard operation.** Use the **[Up]** and **[Down]** buttons to select "Off" if you wish to switch the lamp light sensor Off and press **[Enter]** to confirm or **[Mode]** to cancel and return to the menu.

**Important: The option "Off" is for "emergency operation" only if the lamp light sensor is defective and you will wait for a service intervention!** If the lamp light sensor is switched Off, the error messages "LAEr,SnEr,HEAt" will not appear on the display (only the message "HEAt" will appear if the lamp was turned off and on within 5 minutes) and at switching the lamp on the electronics will still try to ignite the lamp until it shines (even when the lamp is damaged or absent), on this account some electronics parts could be damaged!

## **di SP.** Display adjusting

This function allows you to adjust the display settings:

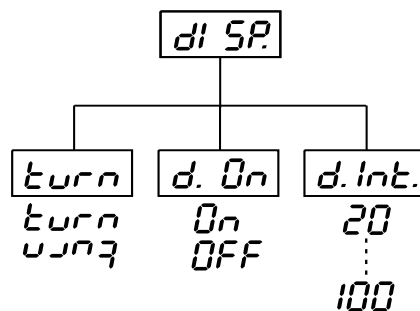

## **di. nt.** Display intensity

With this function you can adjust the display-intensity from 20% to 100%. Use the **[Up]** and **[Down]** buttons to select the level of the display- intensity and press **[Enter]** to confirm or **[Mode]** to cancel and return to the menu.

## **turn** Display-reverse

With this function, you can rotate the display by 180°. Use the **[Up]** and **[Down]** buttons to select "normal display" or "display turned by 180°" and press **[Enter]** to confirm or **[Mode]** to cancel and return to the menu.

## **d.On** Display-On

This function allows you to keep the display on or to turn off automatically 2 minutes after last pressing any button on the control panel. Use the **[Up]** and **[Down]** buttons to select "On" if you wish to keep the display on or "Off" if you wish to turn off automatically 2 minutes after last pressing any button on the control panel and press **[Enter]** to confirm or **[Mode]** to cancel and return to the menu.

## FAN.S

### Fan speed operating modes

By using this function you can choose 5 types of the fan speed operating modes. Browse through this menu by the pressing [Up] and [Down] buttons - the display shows step by step these messages: "Auto,HIGH, reG, LoOF, LoHI". Press [Enter] if you wish to select one of them or [Mode] to cancel and return to the menu.

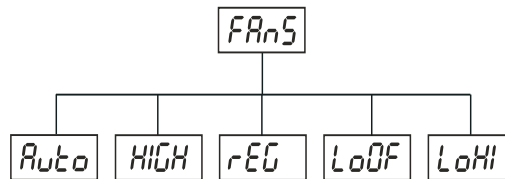

#### Auto Continuous controlling of the fan speed without the DMX value

The fan automatically raises its speed in order to control inside temperature of the lighting, if the temperature inside increases about certain level (the low fan speed reduces the cooling of the lighting). This cycle can repeat several times until the temperature inside is on suitable level. The initial level of the fan speed can't be adjusted by the DMX.

#### HIGH High (max.) speed of fans

The cooling fan works on max. speed (max. cooling)

#### reG. Continuous controlling of the fan speed

This mode is similar to "Auto", but the initial level of the fan speed can be adjusted by the DMX.

#### LoOF. Low speed/Switch Off the lamp operating

The fan keeps the adjusted low speed until the temperature exceeds max. inside temperature of the fixture, then the SCAN 250 XT automatically switches off the lamp.

#### LoHI. Low/high speed of the fan operating

The fan keeps the adjusted low speed until the temperature exceeds max. inside temperature of the fixture, then the SCAN 250 XT automatically switches from low to high the fan speed.

**Note:** The modes "Auto" and "HIGH" don't interact to the DMX value on the channel 6 (0-127)!



## Default settings

Press **[Enter]** to reset all fixture personalities (not the adjusting functions) to the default values. On the display will appear "rSt" meaning that the fixture makes the reset. See the table of personality setting and their default positions.

Personality	Display	Default values (SHADED)
Pan reverse	rPAn	On
		OFF
Tilt reverse	rtilt	On
		OFF
Movement resolution	16br	Mod1
		Mod2
		8bit
Lamp On after switch. the fixture On	LAAU	On
		OFF
Lamp Off via DMX	dLOF	On
		OFF
Lamp On if DMX is present	dNOOn	On
		OFF
Lamp Off if DMX is missing	dNOF	On
		OFF
Display-On	d On	On
		OFF
Display intensity	d Int	20 40 60 80 100
		turn
Display- reverse	turn	turn
		turn
Switch On/Off the lamp light sensor	EnSn	On
		OFF
Fan speed operating modes	FAnS	Auto
		HIGH
		REG
		LoOF
		LoHI

## 8.5 Switching On/Off the lamp



Press the **[Mode]** button in order to access the main menu. Browse through the menu by pressing the **[Up]** and **[Down]** buttons until the display shows "LAMP". Confirm by pressing **[Enter]** button.

Use the **[Up]** and **[Down]** buttons to select "On" to switch On the lamp and "Off" to switch Off the lamp and press **[Enter]** to confirm or **[Mode]** to cancel.

## 8.6 Test sequences



This function allows you to run a special demo-test sequences without an external controller, which will show you some possibilities of using the SCAN 250 XT. Press **[Up]** and **[Down]** keys to select the "Mod1" or "Mod2"

sequences. The "Mod1" is suitable for projections on the wall, ceiling or ground without any mirror-movement, the "Mod2" uses all SCAN 250 XT functions and therefore is good for a complete introduction of the fixture. Select "Mod1" or "Mod2" by [Up] and [Down] buttons and press [Enter] to confirm the choice. If the test program is running, messages "run/test" blink on the display.

If you want to pause the running program in the required position, press the [Enter]-button (messages "PAUS"/"test" blink). To continue the program running, press the [Enter]-button again.

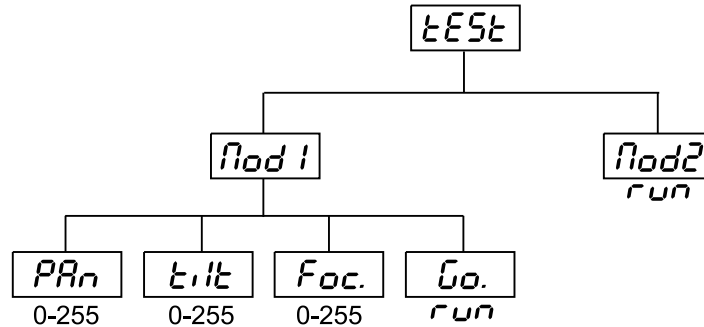

## 8.7 Stand-alone setting



This menu offers options for stand-alone mode as a selection of the playing program, programming and modifying current programs.

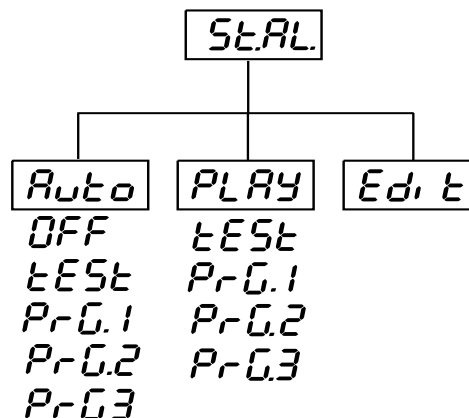

This function allows you to select the program which will be played in the stand-alone mode after switching the fixture On. Use the [Up] and [Down] buttons to select desired program ("tEst"- built-in program) or "OFF" if you don't want trigger any program after switching the fixture On and press [Enter] to confirm or [Mode] to cancel and return to the menu. Selected program will be played continuously in a loop as long as it appears on the display. This option should be set "OFF" for all slaves in the master/slave chain by reason of the right program starts.

For example: You have selected program "PrG.3" in this menu and:

this fixture is set as a single fixture (master/slave or controller operating)- the fixture will run its program "PrG.3".

this fixture is set as a master in a data chain- the fixture will run its program "PrG.3".

this fixture is set as a slave in a data chain- the fixture will run its program according to the master (if the master runs its own program "PrG.1", the slave will run its own program "PrG.1" also).

Note: If the fixture operates in the controller mode (DMX controller is connected) and any program from this menu is selected, in this case the fixture will not respond to the DMX controller after switching On and will play selected program.



## Playing program

This function allows you to run a built-in program "tEst" and the 3 freely-programmable programs "PrG.1,PrG.2,PrG.3". Press [Up] or [Down] buttons to select the desired program and press [Enter] to run the program which will be played continuously in a loop.

If you want to pause the running program in the required position, press the [Enter]-button (messages "PAUS"/"program No." blink). To continue the program running, press the [Enter]-button again.

Note: If the fixture operates in the controller mode (DMX controller is connected) and any program from this function is selected in this case the fixture will not respond to the DMX controller and will play selected program. You can't play programs on the slave fixtures from their control panels if the master fixture is switched On and connected to the slaves (playing is forced by the master).



## Editing program

This menu item allows you to select a program to edit or create. The SCAN 250 XT has one built-in program ("tEst") and the 3 free programs, each up to 99 steps.

If the fixture is set as a master, then you may edit any program in the slaves. You can't edit programs on the slave fixtures from their control panels if the master fixture is switched on and connected to the slaves (editing is possible by the master control panel only).

### Procedure:

1. Press [Up] or [Down]-button to select the program you want to edit ("PrG.1" - "PrG.3") and press [Enter].
2. Press [Up] or [Down]-button to select the desired fixture ("MASt." - "SLA.9") and press [Enter]-button.
3. Press [Up] or [Down]-button to select the desired program step ("St.01" - "St.99") and press [Enter]-button.
4. Press [Up] or [Down]-button to select the desired item and press [Enter]-button. Now you can edit by [Up] or [Down] buttons the DMX value for selected item:

- "P.End." - a total number of the program steps, value 1-99. **This value you must set before start programming** (e.g. if you want to create program with the 10 steps, set the value onto 10).
- "PAAn" - a pan, value 0-255
- "tilt" - a tilt, value 0-255
- "F.PAn" - a fine pan, value 0-255
- "F.tilt" - a fine tilt, value 0-255
- "SPEd" - a speed of PAN/TILT movement, value 0-255
- "Colo." - a colour wheel, value 0-255
- "EFFE." - a frost, cor. filters, 3-facet prism, value 0-255
- "P.rot" - a prism rotation, value 0-255
- "r.Gob." - a rot. gobo, value 0-255
- "G.rot." - a rot. gobo rotation, value 0-255
- "Foc." - a focus, value 0-255
- "Stro." - a strobe, value 0-255
- "dimr" - a dimmer, value 0-255
- "S.tim." - a step time, value 0,1-25,5 seconds
- "COPY." - a copying the current prog. step to the next prog. step. If the last prog. step is copied to the next prog. step, parameter "P.End" is increased about 1 by itself (except step 99).

5. Press [Enter]-button to confirm adjusted value.

6. Press [Mode]-button, select next prog. step and repeat this procedure (steps 4 and 6).

The editing programs "PrG.1,PrG.2,PrG.3" are saved in the current modified fixture (master or slave 1-9).

## 8.8 Reset function



Press [Enter] button to run a reset. This option enables the SCAN 250 XT to index all effects (functions) and return to their standard positions.



## 8.9 Special functions

**SPEC.**

Use the **[Up]** and **[Down]** buttons to browse through the special functions and select the one by pressing **[Enter]**.

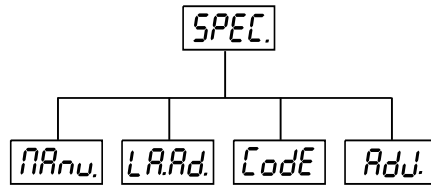

**PA nu.**

### Manual control of effects

The function allows you to control manually the channel functions of the fixture. Use the **[Up]** and **[Down]** buttons to select desired function and press **[Enter]** to adjust the effect or **[Mode]** to cancel and return to the menu.

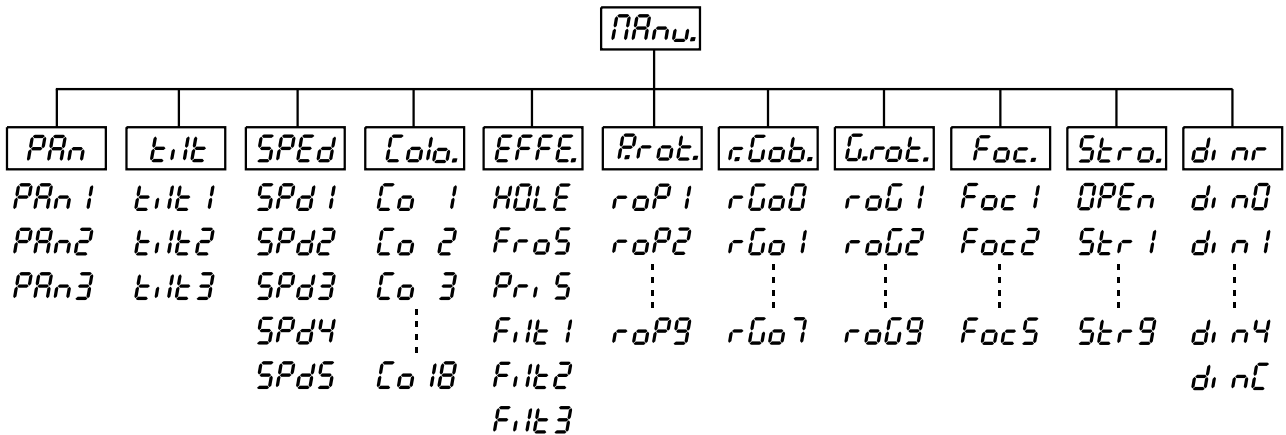

**L.A.Ad.**

### Lamp adjustment

This function can be used when you make the fine adjustment of the lamp. If you select "L.A.Ad" pressing by **[Enter]**-button, all effects will be canceled, shutter will be opened and the dimmer intensity will be set onto 100%. By using the options "PAN, tilt, Foc" you can focus the light on a flat surface (wall) and perform the fine lamp adjustment.

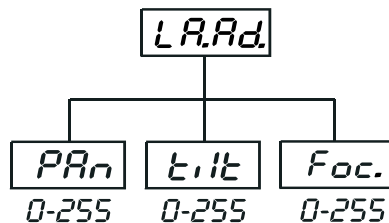

**Code**

### Fixture code

The option contains identification code (1-9999) for the fixture, which is used for the master/slave operation.



## Adjusting the default positions of colour, gobo and effect wheels

By this function you can calibrate and adjust the colour and gobos to their standard/right positions. Use the **[Up]** and **[Down]** keys to browse through the adjusting menu - the display shows step by step these messages: "**PAn, Tilt,FPAn,FtILt, SPEd,Func,Colo, EFEE, Prot,rGob, rotG, Foc, Stro, dimr, FCAL**" by which you can adjust the fixture to the required/desired position (0-255) before the function calibration. Then when the positioning is finished use the last "**FCAL**" function (Fixture calibration).

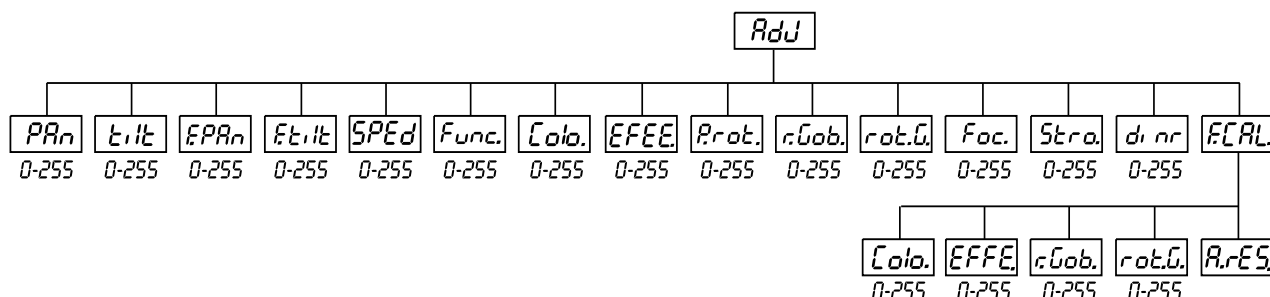

### 1. Calibration via the control board

Press **[Enter]** and the **[Up]** and **[Down]** keys in order to display the following messages: "**Colo, EFEC, rGob, rotG,**" for very smooth function calibration. Select one of them, press **[Enter]** and use the **[Up]** and **[Down]** keys in order to adjust their right value from 0 to 255. Then press **[Enter]** to confirm or **[Menu]** to cancel and return to the menu. This can be repeated for each calibration parameter if it is required. When the calibration is finished, it is necessary to use the "**ArES**" function in order to write the calibration values to the memory (EPROM) and to make a reset in order to check the newly adjusted positions of the colour, gobo and effect wheels. When the reset of the fixture is finished, the display will show the "**FCAL**" message. Press **[Enter]** to repeat the calibration or **[Menu]** to return to the "**Adj**" menu.

### 2. Calibration via the external controller

Press **[Enter]** and the **[Up]** and **[Down]** keys in order to display the following messages: "**Colo,EFEC, rGob, rotG,**" - calibration parameters. Select one of them and press **[Enter]**.

Now you can calibrate the the colour, gobo and effect wheel by your controller. The DMX calibration protocol is described in the table.

#### DMX Calibration protocol:

DMX channel	Function		
1	Colour	m m S c v m o r e o o s e t h e t P	
2	No function		Calibration 0-255
3	Effect		Calibration 0-255
4	Rotating gobo		Calibration 0-255
5	Gobo rotating		Calibration 0-255
6	No function		
7	Colours	Standard protocol	
8	No function		
9	Effect(prism)	Standard protocol	
10	Prism rotation	Standard protocol	
11	Rotating gobos	Standard protocol	
12	Gobo rotation	Standard protocol	
13	No function		
14	Focus	Standard protocol	
15	Strobo	Standard protocol	
16	Dimmer	Standard protocol	

After having calibrated required functions press **[Enter]** to confirm (or **[Menu]** to cancel and return to the menu without reset by the "ArES" function) and use the "ArES" function in order to write the calibration values to the memory (EEPROM) and to make a reset in order to check the new adjusted positions of the colour, effect and gobo wheels.

## 9. Error and information messages

### **HEAt**

This message appears if you try to switch on the lamp within 5 minutes after having switched it off (the lamp is too hot). The message will appear on the display if the lamp doesn't ignite within 28 seconds. The SCAN 250 XT will store this information and automatically ignite the lamp when the 5 minutes period has expired.

**Caution:** The message is disabled if the lamp light sensor (function "En.Sn.") is switched Off (only if the lamp was turned Off and On within 5 minutes, the message "HEAt" will appear).

### **LA.Er.**

The ignition of the lamp is seven times unsuccessful (the "HEAt" message appeared six times before), and the display shows "LA.Er", meaning that the lamp could be damaged or even missed, the fixture is overheating (this can occur if the ambient temperature is 45° C or more) or there could be a failure on the ignitor or ballast.

Please place or replace the lamp, check the ambient temperature or contact your dealer if the situation was not caused by the lamp.

**Caution:** The message is disabled if the lamp light sensor (function "En.Sn.") is switched Off.

### **FAn**

The message informs you that the fixture was overheating and switched off. This message will appear on the display if the fan speed operating "LOOF" was selected.

### **MbEr**

This message informs you that the main PCB does not communicate correctly with the Control Board.

### **CoEr (color-wheel error)**

This message will appear after the reset of the fixture if the magnetic-indexing circuit malfunctions (sensor failed or magnet missing) or the stepping-motor is defective (or its driver circuit on the main PCB). The color-wheel is not located in the default position after the reset.

### **rGEr (rotating gobo wheel error)**

This message will appear after the reset of the fixture if the magnetic-indexing circuit malfunctions (sensor failed or magnet missing) or the stepper motor is failed (or its driver circuit on the main PCB). The rotating gobo wheel is not after the reset in the default position.

### **IGEr (rotating gobo indexing error)**

This message will appear after the reset of the fixture if the magnetic-indexing circuit malfunctions (sensor failed or magnet missing) or the stepper motor is failed (or its driver circuit on the main PCB). The rotating gobo is not after the reset in the default position.

### **EFEr (effect wheel error)**

This message will appear after the reset of the fixture if the magnetic-indexing circuit malfunctions (sensor failed or magnet missing) or the stepper motor is failed (or its driver circuit on the main PCB). The effect wheel is not after the reset in the default position.

### **FtEr**

This error message informs you that the fixture was overheating (occured if the ambient temperature is 45° C or more) and that the relay switched off the lamp. This message will appear on the display until the temperature will be on a suitable level, then the display will show the "HEAt" message meaning the lamp is too hot (explanation see above).

### **MAEr**

The message informs you that the fixture was addressed as a master and DMX signal is connected to its input. Disconnect the DMX controller from fixture's input and address the fixture as the master again. The message appears after switching the fixture Off and On.

### **SnEr**

This message appears if the lamp lighting sensor is failed.

**Caution:** The message is disabled if the lamp light sensor (function "En.Sn.") is switched Off.

**PoEr**

This message will appear if the fixture was shortly disconnect from the main.

**FrEr**

It will appear if the frequency of the main is not standard 50 or 60Hz.

## 10. Technical specifications

**Power supply:**

EU version -Voltage.....208/230/240V AC, 50/60 Hz ~  
-Fuse.....T 3.15 A@ 230 V  
US version -Voltage.....100/120/208/230/240V AC, 50/60 Hz ~  
-Fuse.....T 6.3 A@120V  
-Power consumption.....500VA

**Motors:**

-9 high quality stepping-motors controlled by microprocessors

**Lamps:**

-Philips MSD 250 or MSD250/2 GY9.5

**Optical system:**

-Double condensor lens with high efficiency parabolic mirror  
-Standard 15° objective  
-Optional narrow 12° objective or wide 18° objective

**Colours:**

- 11 dichroic-filters plus white  
- Colour-wheel with variable rotation speed

**Rotating gobos:**

- 4 metal gobo, 1 glass gobos and 1 dichroic gobo rotating in both directions at different speeds  
- gobo indexing  
- rotating gobo wheel cont. rotation  
-Metal gobos:outside diameter=26.9mm,image diameter=22.5mm,stainless steel,thickness=0.15mm  
-Multicolor dichroic gobo:outside diameter=26.8mm,thickness=1.1mm,high temperature borofloat or better glass  
-Glass gobo:outside diameter=26.8mm,max.thickness=4mm,high temperature borofloat or better glass  
-3 additional metal gobos and 2 glass gobos are included

**Strobe:**

- Strobe effect with variable speed (1 - 10 flashes per second)

**Dimmer:**

-Smooth dimmer from 0 - 100 %

**Effects:**

- Special effect wheel with frost filter, color temperature filters 3200 K and 5600 K, UV filter

**Prisma:**

- 3 facet prism rotating in both directions at different speeds situated on effect wheel

**Focus:**

-Motorized focus from near to far

**Beampath:**

**15° radiation angle**

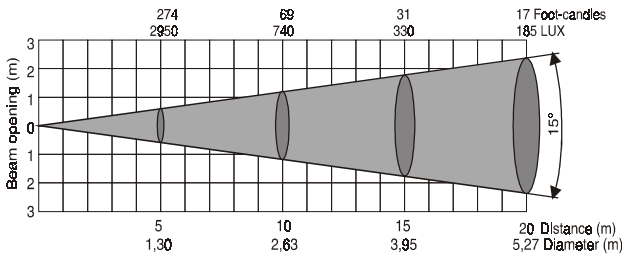

**15° radiation angle with frost**

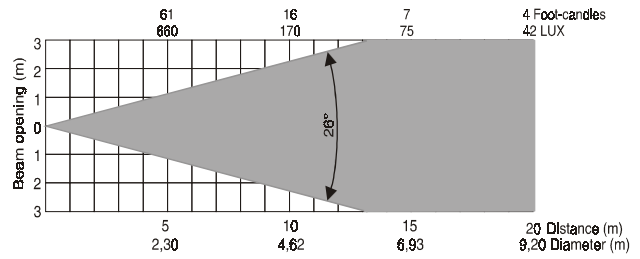

**18° radiation angle**

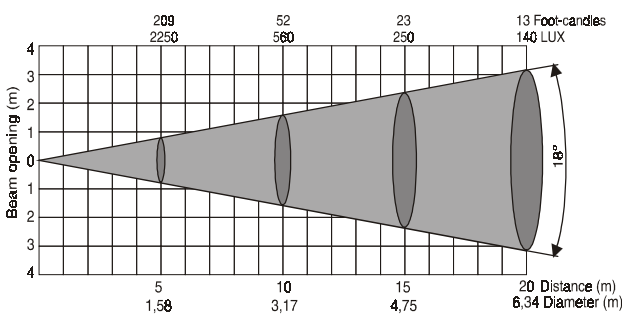

**18° radiation angle with frost**

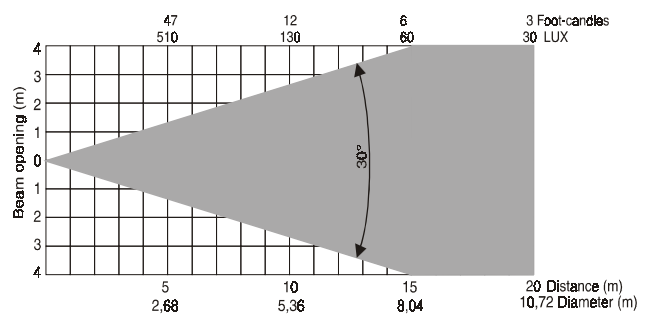

**12° radiation angle**

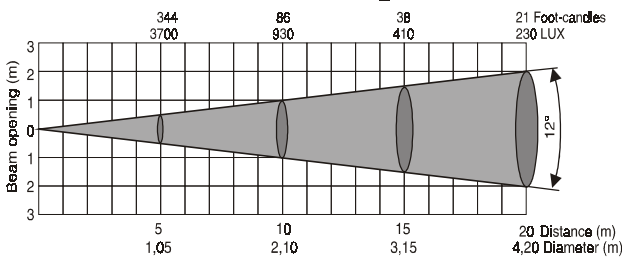

**12° radiation angle with frost**

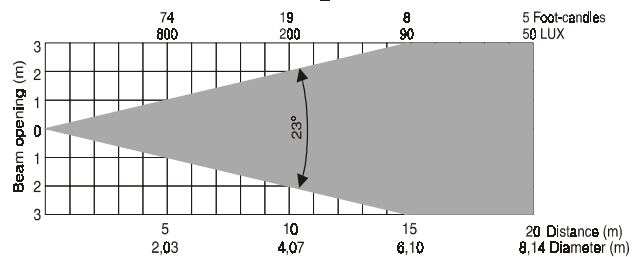

**Electronics:**

- Addressing, special functions setting, effects calibration via control panel with 4-digit LED display
- Readout fixture and lamp usage, receiving DMX values, temperature, etc
- Built-in analyzer for easy fault finding, error messages
- Built-in demo sequences
- Master-slave operation
- Silent fans cooling, remotely controllable speed of fans
- Self-resettable thermo-fuse
- Digital serial input DMX-512
- DMX-control via every standard DMX controller
- 14 DMX-channels (8 bit Pan/Tilt movement resolution)
- 16 DMX-channels (16 bit Pan/Tilt movement resolution):

Channel	Mode 1-16bit (default)	Mode 2-16bit	8 bit
1	Pan	Pan	Pan
2	Tilt	Fine Pan	Tilt
3	Fine Pan	Tilt	Pan/Tilt speed
4	Fine Tilt	Fine Tilt	Fans, Lamp On/Off
5	Pan/Tilt speed	Pan/Tilt speed	Colours
6	Fans, On/Off lamp	Fans, On/Off lamp	No function
7	Colours	Colours	Prism
8	No function	No function	Prism rotation
9	Prism	Prism	Rotating gobos
10	Prism rotation	Prism rotation	Gobo rotation
11	Rotating gobos	Rotating gobos	No function
12	Rot.gobo rotation	Rot.gobo rotation	Focus
13	No function	No function	Shutter, Strobe
14	Focus	Focus	Dimmer
15	Shutter, strobe	Shutter, strobe	
16	Dimmer	Dimmer	

## Temperatures:

- Maximum ambient temperature  $t_a$ : 45° C
- Maximum housing temperature  $t_B$  (steady state): 95° C

## Minimum distances:

- Min.distance from flammable surfaces: 0,5m
- Min.distance to lighted object: 0,8m

## Housing

- Easy access to lamp and main components thanks to large opening cover and the projector's modular construction.

## Dimensions (mm):

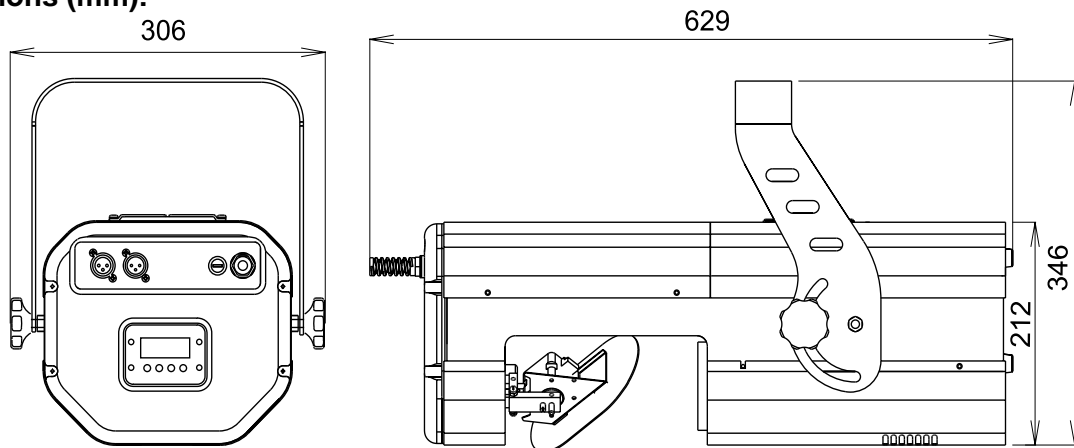

## Weight:

16 kg

## Accessories

- Accessories gobo-set 1.....15050010

## Optional accessories:

- Objective12° SCN.....99010184
- Lens-module 18°.....99010200

## 11. Maintenance and cleaning

It is absolutely essential that the fixture is kept clean and that dust, dirt and smoke-fluid residues must not build up on or within the fixture. Otherwise, the fixture's light-output will be significantly reduced. Regular cleaning will not only ensure the maximum light-output, but will also allow the fixture to function reliably throughout its life. A soft lint-free cloth moistened with any good glass cleaning fluid is recommended, under no circumstances should alcohol or solvents be used!

**DANGER!**  
**Disconnect from the mains before starting any  
maintenance work**

The front mirror and objective lens will require weekly cleaning as smoke-fluid tends to building up residues, reducing the light-output very quickly. The cooling-fan should be cleaned monthly.

The gobos may be cleaned with a soft brush. The interior of the projector should be cleaned at least annually using a vacuum-cleaner or an air-jet.

The dichroic colour-filters, the gobo-wheel and the internal lenses should be cleaned monthly.

To ensure a proper function of the gobo-wheel, we recommend lubrication in six month intervals. The quantity of oil must not be excessive in order to avoid that oil runs out when the gobo-wheel rotates.

Version 1.1

