

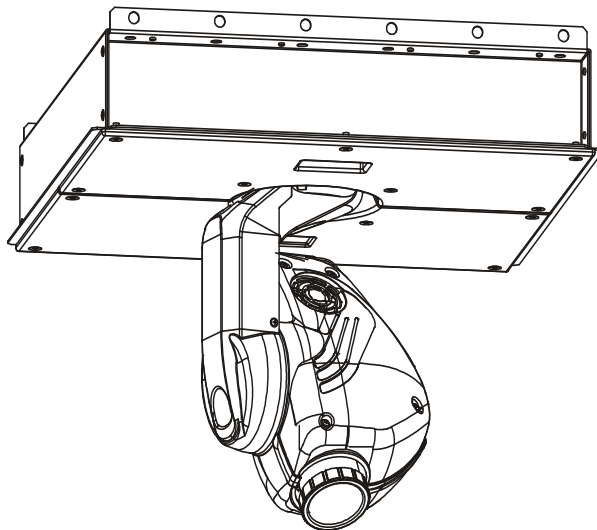

ArcSpot 170 Recessed



USER MANUAL

Version 1.0

ARCSPOT 170 RECESSED

Table of contents

1. Safety instructions	3
2. Operating determinations	4
3. Description of the device	5
4. Installation	6
4.1 Fitting/Exchanging the lamp	6
4.2 Lamp adjustment	6
4.3 Inserting/Exchanging the colours and rotating gobos	7
4.4 Rigging	8
4.5 DMX- 512 connection, master/slave connection	11
5. DMX Protocol	12
7. Controller mode	16
7.1 DMX addressing	16
7.2 Remotely controllable functions	16
8. Stand - alone mode	17
9. Functions of the control panel	18
9.1 Addressing	18
9.2 Slave control	19
9.3 Fixture informations	19
9.4 Personality options	20
9.5 Switching On/Off the lamp	24
9.6 Test sequences	25
9.7 Stand-alone setting	25
9.8 Reset function	27
9.9 Special functions	27
10. Error and information messages	28
11. Technical specifications	29
12. Maintenance and cleaning	32
13. Appendix 1 - Menu map	34
14. Appendix 2 - Changing the power supply settings	37
15. Appendix 3 - Box versions and dimensions	38

CAUTION!

***Keep this device away from rain and moisture!
Unplug mains lead before opening the housing!***

**FOR YOUR OWN SAFETY, PLEASE READ THIS USER MANUAL CAREFULLY
BEFORE YOU INITIAL START - UP!**

1. Safety instructions

***Caution ! Be careful with your operations. With a dangerous voltage you can suffer
a dangerous electric shock when touching the wires***

This device has left our premises in absolutely perfect condition. In order to maintain this condition and to ensure a safe operation, it is absolutely necessary for the user to follow the safety instructions and warning notes written in this manual.

Important:

Damages caused by the disregard of this user manual are not subject to warranty. The dealer will not accept liability for any resulting defects or problems.

If the device has been exposed to drastic temperature fluctuation (e.g. after transportation), do not switch it on immediately. The arising condensation water might damage your device. Leave the device switched off until it has reached room temperature.

This device falls under protection-class I. The power plug must only be plugged into a protection class I outlet. Never let the power cord come into contact with other cables!

Make sure that the power cord is never crimped or damaged by sharp edges.

Always disconnect from the mains, when the device is not in use or before cleaning it.

During the initial start-up some smoke or smell may arise. This is a normal process and does not necessarily mean that the device is defective.

Caution: During the operation, the housing becomes very hot.

Do not switch the device on and off in short intervals as this would reduce the lamp's life.

HEALTH HAZARD!

***Never look directly into the light source, as sensitive persons may suffer
an epileptic shock
(especially meant for epileptics) !***

Please consider that damages caused by manual modifications to the device are not subject to warranty.

Keep away children and amateurs !

2. Operating determinations

This device is a moving head for creating decorative effects and was designed for indoor use only.

This device is suitable for ceiling mounting applications in discotheques, theatres etc.

Lighting effects are not designed for permanent operation. Consistent operation breaks will ensure that the device will serve you for a long time without defects.

Never run the device without lamp!

Do not shake the device. Avoid brute force when installing or operating the device.

Never lift the fixture by holding it at the projector head, as the mechanics may be damaged. Always hold the fixture at the transport handles.

When choosing the installation-spot, please make sure that the device is not exposed to extreme heat, moisture or dust. There should not be any cables lying around. You endanger your own and the safety of others!

The minimum distance between light-output and the illuminated surface must be more than 0,8 meter.

Make sure that the area below the installation place is blocked when rigging, derigging or servicing the fixture.

Only operate the fixture after having checked that the housing is firmly closed and all screws are tightly fastened.

The lamp must never be ignited if the objective-lens or any housing-cover is open, as discharge lamps may explode .

The maximum ambient temperature t_a must never be exceeded.

CAUTION!

The lens has to be replaced when it is obviously damaged, so that its function is impaired, e. g. due to cracks or deep scratches!

Operate the device only after having familiarized with its functions. Do not permit operation by persons not qualified for operating the device. Most damages are the result of unprofessional operation!

CAUTION!

The lamp has to be replaced when it is damaged or deformed due to the heat!

Please use the original packaging if the device is to be transported.

Please consider that unauthorized modifications on the device are forbidden due to safety reasons!

If this device will be operated in any way different to the one described in this manual, the product may suffer damages and the guarantee becomes void. Furthermore, any other operation may lead to dangers like short-circuit, burns, electric shock, lamp explosion, crash etc.

DANGER TO LIFE!

For protection from dangerous electric shock, the fixture must be installed in ceiling box and covered with box covers before applying power!

3.Description of the device

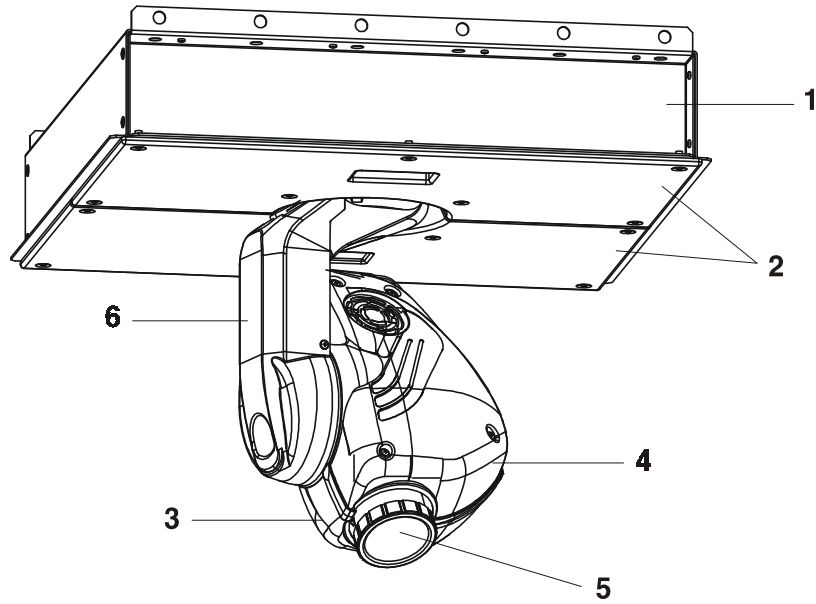

- 1 - Ceiling box
- 2 - Box covers
- 3 - Top cover of the head
- 4 - Bottom cover of the head
- 5 - Objective
- 6 - Arm

Moving head base

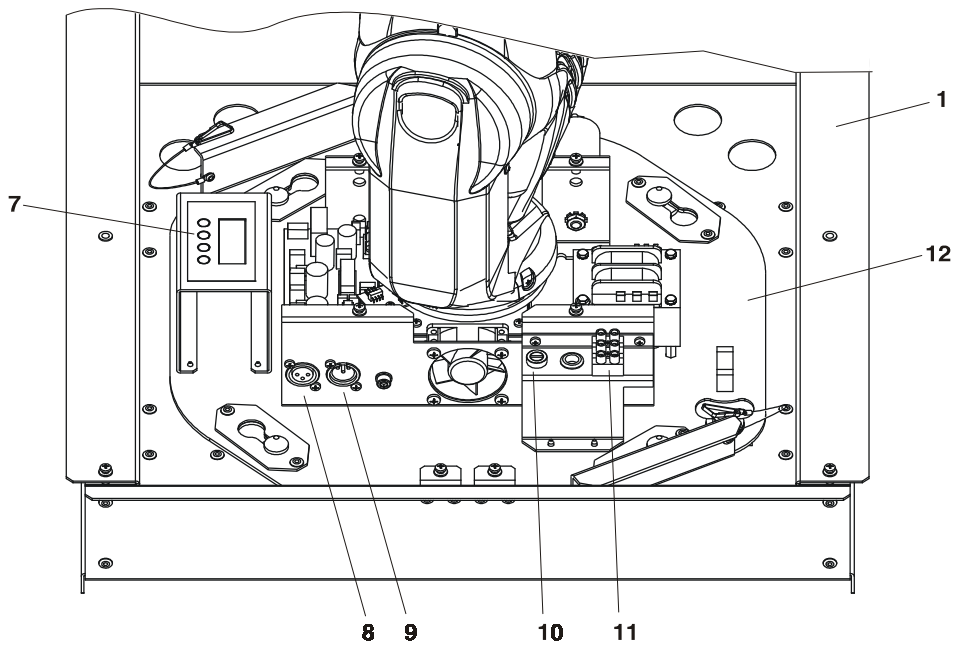

- 1 - Ceiling box
- 7 - Control panel
- 8 - DMX output
- 9 - DMX input
- 10 - Fuse holder
- 11 - Power terminals
- 12 - Moving head base

Control panel

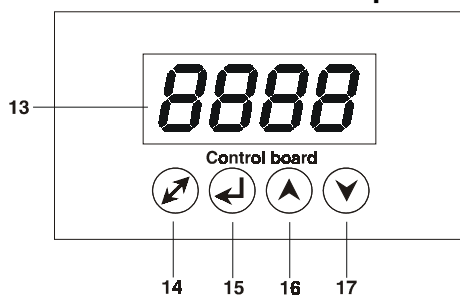

- 13 - Display
- 14 - Mode-button
- 15 - Enter-button
- 16 - Up-button
- 17 - Down-button

4. Installation

4.1 Fitting/Exchanging the lamp

DANGER !
Isolate the fixture from AC power before replacing the lamp.

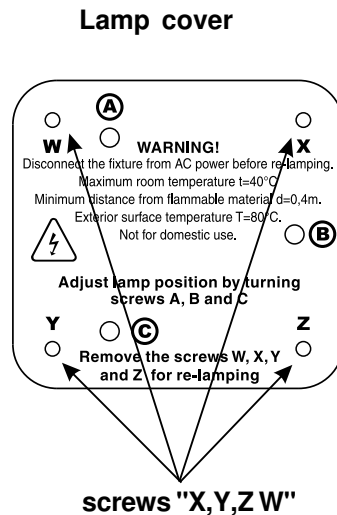

To insert the lamp (CDM-SA/T 150W/942):

1. Disconnect the fixture from power and allow it to cool.
 2. Loosen the 4 screws „X, Y, Z,W” on the lamp socket assembly at the back of the head.
 3. Gently pull the lamp socket assembly out of the head. Hold this assembly while replacing the lamp.
 4. Holding the lamp by its ceramic base, carefully pull the lamp straight out of the lamp socket.
 5. Holding the new lamp by its ceramic base, gently insert the lamp to the lamp socket. Make sure that the lamp is installed tightly into the lamp socket.
- Do not install a lamp with a higher wattage! A lamp like this generates temperatures the device is not designed for. Damages caused by non-observance are not subject to warranty. Please follow the lamp manufacturer’s notes! Do not touch the glass bulb bare hand during the installation!
6. Reinsert the lamp socket assembly and tighten the 4 screws again.
 7. Align the new lamp (see instructions below)
 8. Reset the "LAti/rSEt" and "LAsT/rSEt" counters in the "InFO" menu on the control panel, by pressing the [▲] and [▼] buttons in one time and then confirming with the [↵] button.

Do not operate this fixture with opened housing-cover!

4.2 Lamp adjustment

The lamp holder is aligned at the factory. Due to differences between lamps, fine adjustment may improve light performance:

1. Switch on the fixture and after reset turn on the lamp.
 2. Cancel all effects, open the shutter and focus the light on a flat surface (wall) using either DMX controller or function "LAA d" in the "Special functions" of the control board.
 3. Center the hot-spot (the brightest part of the beam) using the 3 adjustment screws „A, B, C”. Turn one screw at a time to drag the hot-spot, diagonally across the projected image. If you cannot detect a hot-spot, adjust the lamp until the light is even.
- To reduce a hot-spot, pull the lamp in by turning all three screws „A, B, C” clockwise 1/4-turn at a time until the light is evenly distributed.

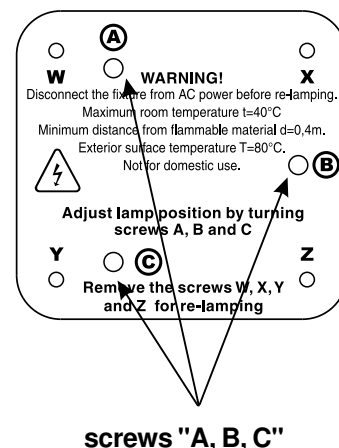

If the light is brighter around the edge than it is in the center, or if light output is low, the lamp is too far back in the reflector. „Push” the lamp out by turning the screws „A, B, C” counterclockwise 1/4-turn at a time the light is bright and evenly distributed.

4.3 Inserting/Exchanging the colours and rotating gobos

DANGER!
Install the colours or gobos with the device switched off only.
The main switch of the device installations must be OFF !

To insert the new colours or gobos open the top cover of the head by loosening the 2 quarter turn fasteners.

Colour-wheel:

Gently bend out the colour-module to release it from the 2 fixative holes and eject it from the pressing snap. Put the new colour-module back under the pressing snap and push it to the 2 fixative holes.

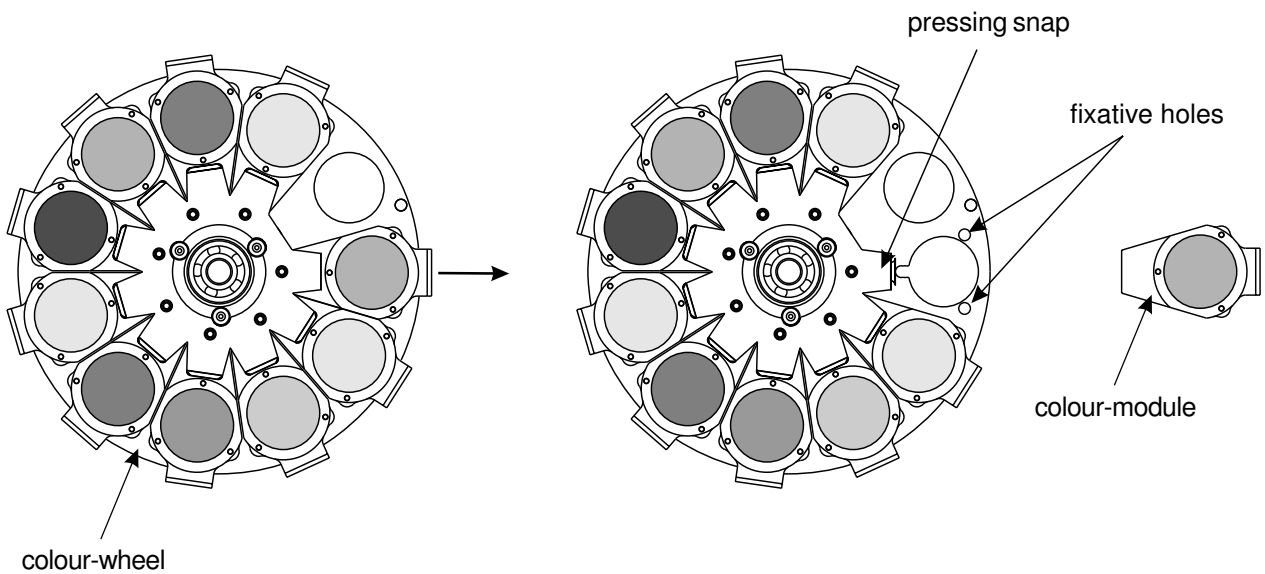

Rotating gobo-wheel:

Gently bend out the gobo module to release it from the fixative holes and eject it from the pressing snap. Press the ends of the fixation-ring together with an appropriate tool and remove it from the gobo holder. Remove the gobo and insert the new gobo. Press the ends of the fixation-ring together and insert it in the front of the gobo. Put the gobo module back under the pressing snap and push it to the 2 fixative holes.

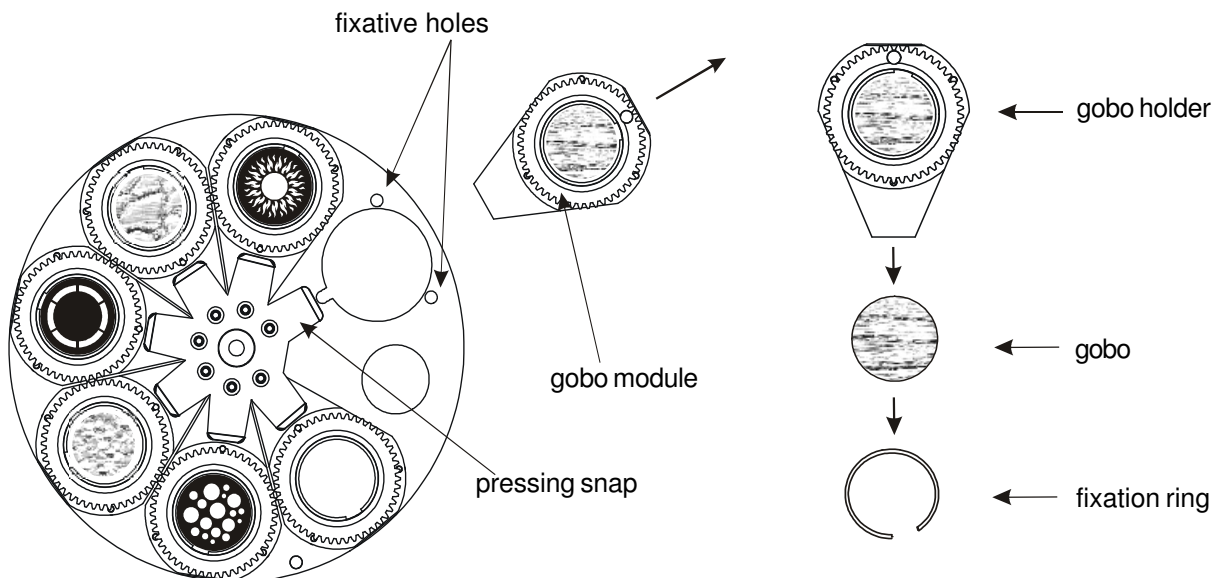

CAUTION!
**Never unscrew the screws of the rotating gobo
as the ball bearing will otherwise be opened!**

4.4 Rigging

DANGER TO LIFE!
**Please consider the respective national norms during the installation! The
installation must only be carried out by an authorized dealer!**

The moving head is designed for ceiling mounting.

The installation of the projector has to be built and constructed in a way that it can hold 10 times the weight for 1 hour without any harmful deformation.

When rigging, derigging or servicing the fixture staying in the area below the installation place, under high working places and other endangered areas is forbidden.

The operator has to make sure that safety-relating and machine-technical installations are approved by an expert before taking into operation for the first time and after changes before taking into operation another time.

The operator has to make sure that safety-relating and machine-technical installations are approved by an expert after every four years in the course of an acceptance test.

The operator has to make sure that safety relating and machine-technical installations are approved by a skilled person once a year.

The moving head should be installed outside areas where persons may walk by or be seated.

IMPORTANT! OVERHEAD RIGGING REQUIRES EXTENSIVE EXPERIENCE, including (but not limited to) calculating working load limits, installation material being used, and periodic safety inspection of all installation material and the projector. If you lack these qualifications, do not attempt the installation yourself. Improper installation can result in bodily injury and (or) damage to property.

The moving head has to be installed out of the reach of people.

Caution: Moving heads may cause severe injuries when crashing down! If you have doubts concerning the safety of a possible installation, do NOT install the moving head!

Before rigging make sure that the installation area can hold a minimum point load of 10 times the moving head's weight.

Danger of fire !
**When installing the device, make sure there is no highly inflammable
material (decoration articles, etc.) in between a distance of min. 0,5 m.**

CAUTION!
**Make sure that the device is fixed properly! Ensure that
the structure (truss) to which you are attaching the fixtures is secure.**

The ARCSPT 170 RECESSED includes a moving head and a ceiling box for mounting to the lower ceiling.
Installation:

1. Fix the recessed ceiling box (8) to the lower ceiling. Be careful the mounting grid can hold the moving head installation!

The ceiling box must be fixed properly, otherwise the vibration of the mounting structure can occur during the operation of the moving head. Pull the power cable and data cables through the apertures (1) on the bottom of the box.

2. Put the moving head base (4) on the 4 fixative pins (6) in the bottom of the ceiling box (8) and turn the base gently to the right. Insert and tighten clockwise the 2 quick-lock fasteners (7) to secure the moving head in the ceiling box.

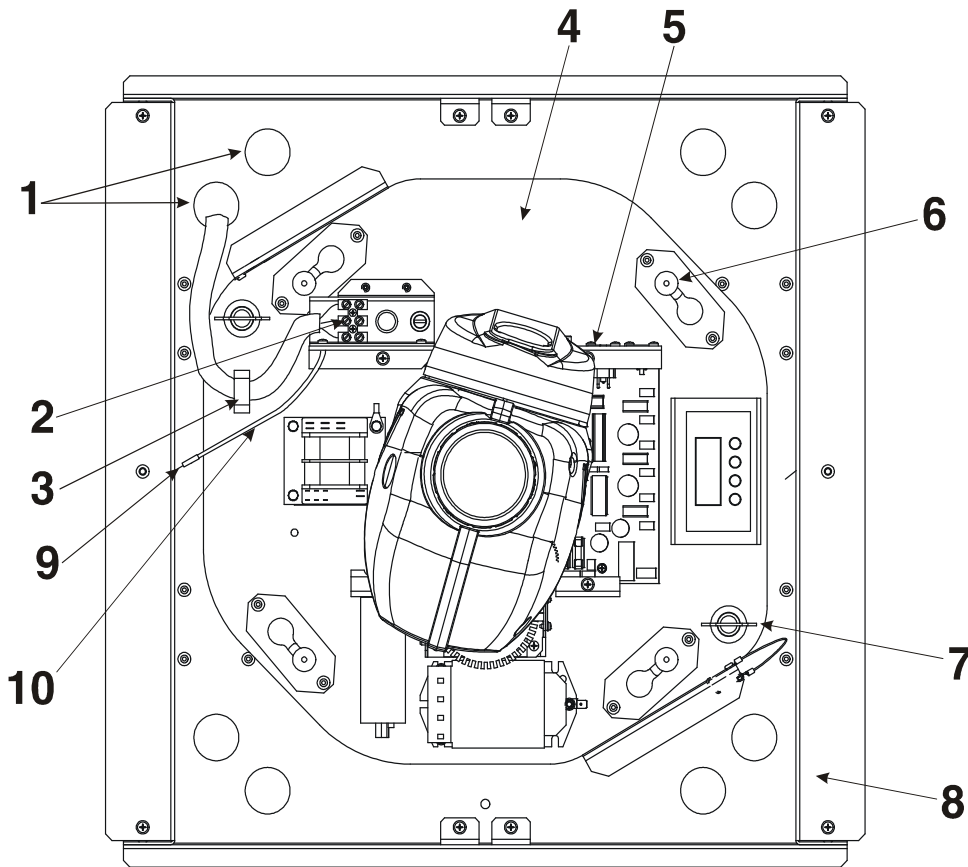

3. Use the 3-wired power cable (the wires with cross-sectional area of 1.5mm²) to connect the power. Verify that the voltage and frequency settings match the local AC supply. The settings are printed on the label on the bottom of the moving head base. If you wish to change the power supply settings, see the chapter Appendix. Pull the power cable through a cable holder (3) and connect it into the connection terminals (2) as follows:

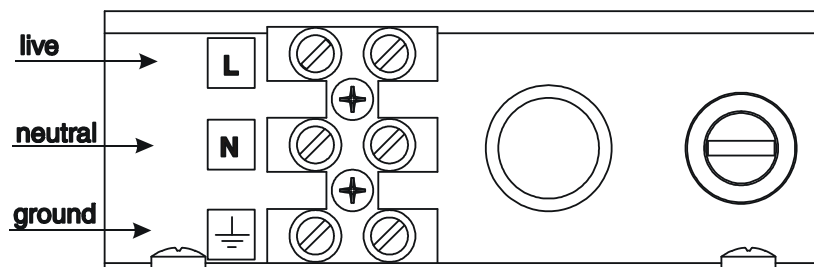

Possible pin identification schemes:

Cable (EU)	Cable (US)	Pin	International
Brown	Black	Live	L
Light blue	White	Neutral	N
Yellow/Green	Green	Earth	

Connect the earth-wire (10) with the earth-terminal (9) on the ceiling box (8).
If you have any doubts about proper installation,consult a qualified electrician!
Make sure the wires are securely connected.Tighten the 2 screws in the cable holder to secure the power cable in it.

***For protection from electric shock,the fixture must be grounded!
Verify the power supply settings before applying power!***

4.Connect the data cables to the fixture data input/output.

5.Fasten the 2 covers on the ceiling box by 14 screws.

***DANGER TO LIFE!
For protection from dangerous electric shock,the fixture must be
installed in ceiling box and covered with box covers before applying power!
Before taking into operation for the first time,the installation has to be
approved by an expert!***

***When installing fixtures side-by-side,
avoid illuminating one fixture with another!***

4.5 DMX- 512 connection, master/slave connection

Use shielded, twisted-pair cable designed for RS-485 applications with low capacitance and characteristic impedance of 120 Ohm.

Occupation of the XLR-connection:

DMX - output
XLR mounting-socket:

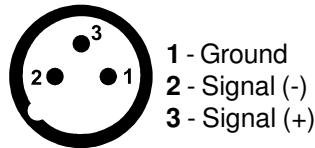

DMX-input
XLR mounting-plug:

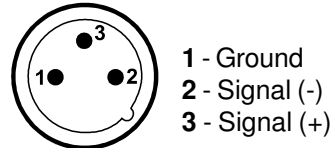

Building a serial DMX-chain:

If you are using the standard controllers, you can connect the DMX-output of the controller directly with the DMX-input of the first fixture in the DMX-chain. If you wish to connect DMX-controllers with other XLR-outputs, you need to use adapter-cables.

Connect the DMX-output of the first fixture in the DMX-chain with the DMX-input of the next fixture. Always connect output with the input of the next fixture until all fixtures are connected.

Caution: At the last fixture, the DMX-cable has to be terminated with a terminator. Solder a 120 Ohm resistor between Signal (-) and Signal (+) into a 3-pin XLR-plug and plug it in the DMX-output of the last fixture.

Building a master/slave-chain:

Connect the DMX-output of the master fixture in the data-chain with the DMX-input of the first slave. Always connect output with the input of the next slave until all slaves are connected (up to 9 fixtures).

Caution: It's necessary to insert the XLR termination plug (with 120 Ohm) into the input of the master fixture and into the output of the last slave fixture in the link in order to ensure proper transmission on the data link.

5. DMX Protocol

16-bit Mode 1 Channel	16-bit Mode 2 Channel	Value	Function	Type of control
1	1	0-255	Pan Pan movement by 530°	proportional
2	3	0-255	Tilt Tilt movement by 280°	proportional
3	2	0-255	Pan fine Fine control of pan movement	proportional
4	4	0-255	Tilt fine Fine control of tilt movement	proportional
5	5	0 1-249 250-252 253-255	Speed of PAN/TILT movement Max. speed (tracking mode) From max. speed to min.speed (vector mode) Max. speed(track.mode),black-out while colour or gobo changes Max. speed(vector mode),black-out while PAN/TILT moving or colour or gobo changes	step proportional step
6	6	0-127 128-139 140-229 230-239 240-255	Lamp on/off,reset No function Lamp on,reset, No function Lamp off after 3 sec No function	step step step step step
7	7	0 11 23 35 46 58 70 81 93 105 116 128-189 190-193 194-255	Colours Open/white Dark green Red Cyan Magenta Blue Yellow Green Pink Dark blue Orange Forwards rainbow effect from fast to slow No rotation Backwards rainbow effect from slow to fast	proportional proportional proportional proportional proportional proportional proportional proportional proportional proportional proportional proportional proportional proportional
8	8	0-11 12-23 24-35 36-47 48-59 60-71 72-83 84-95 96-235	Rotating gobos Open position (hole) Gobo 1 Gobo 2 Gobo 3 Gobo 4 Gobo 5 Gobo 6 Gobo 7 <i>Shaking gobos with variable speed</i>	step step step step step step step step
		96-115 116-135 136-155	Gobo 1 Gobo 2 Gobo 3	proportional proportional proportional

16-bit Mode 1 Channel	16-bit Mode 2 Channel	Value	Function	Type of control
		156-175 176-195 196-215 216-235 236-255	Gobo 4 Gobo 5 Gobo 6 Gobo 7 Gobo wheel rotation from slow to fast	proportional proportional proportional proportional proportional
9	9	0-127 128-189 190-193 194-255	Rotating gobo rotation Gobo indexing Forwards gobo rotation from fast to slow No rotation Backwards gobo rotation from slow to fast	proportional proportional step proportional
10	10	0-255	Focus Continuous adjustment from far to near	
11	11	0-31 32-63 64-95 96-127 128-159 160-191 192-223 224-255	Shutter, Strobe Shutter closed No function (shutter open) Strobe-effect from slow to fast (max. 8 flashes/s) No function (shutter open) Pulse -effect in sequences No function (shutter open) Random strobe-effect from slow to fast No function (shutter open)	step step proportional step proportional step proportional step
12	12	0-255	Dimmer intensity Gradual adjustment of the dimmer intensity from 0 to 100%	proportional

8-bit Mode 3 Channel	16-bit Mode 4 Channel	Value	Function	Type of control
1	1	0-255	Pan Pan movement by 530°	proportional
2	2	0-255	Tilt Tilt movement by 280°	proportional
	3	0-255	Pan fine Fine control of pan movement	proportional
	4	0-255	Tilt fine Fine control of tilt movement	proportional
3	5	0 1-249 250-252 253-255	Speed of PAN/TILT movement Max. speed (tracking mode) From max. speed to min.speed (vector mode) Max. speed(track.mode),black-out while colour or gobo changes Max. speed(vector mode),black-out while PAN/TILT moving or colour or gobo changes	step proportional step
4	6	0-127 128-139 140-229 230-239 240-255	Lamp on/off,reset No function Lamp on,reset, No function Lamp off after 3 sec No function	step step step step step
5	7	0 11 23 35 46 58 70 81 93 105 116 128-189 190-193 194-255	Colours Open/white Dark green Red Cyan Magenta Blue Yellow Green Pink Dark blue Orange Forwards rainbow effect from fast to slow No rotation Backwards rainbow effect from slow to fast	proportional proportional proportional proportional proportional proportional proportional proportional proportional proportional proportional proportional proportional proportional
	8		No function	
	9		No function	
	10		No function	
6	11	0-11 12-23 24-35 36-47 48-59 60-71 72-83 84-95	Rotating gobos Open position (hole) Gobo 1 Gobo 2 Gobo 3 Gobo 4 Gobo 5 Gobo 6 Gobo 7	step step step step step step step step

8-bit Mode 3 Channel	16-bit Mode 4 Channel	Value	Function	Type of control
		96-235 96-115 116-135 136-155 156-175 176-195 196-215 216-235 236-255	Shaking gobos with variable speed Gobo 1 Gobo 2 Gobo 3 Gobo 4 Gobo 5 Gobo 6 Gobo 7 Gobo wheel rotation from slow to fast	proportional proportional proportional proportional proportional proportional proportional proportional
7	12	0-127 128-189 190-193 194-255	Rotating gobo rotation Gobo indexing Forwards gobo rotation from fast to slow No rotation Backwards gobo rotation from slow to fast	proportional proportional step proportional
	13		No function	
8	14	0-255	Focus Continuous adjustment from far to near	
9	15	0-31 32-63 64-95 96-127 128-159 160-191 192-223 224-255	Shutter, Strobe Shutter closed No function (shutter open) Strobe-effect from slow to fast (max. 8 flashes/s) No function (shutter open) Pulse -effect in sequences No function (shutter open) Random strobe-effect from slow to fast No function (shutter open)	step step proportional step proportional step proportional step
10	16	0-255	Dimmer intensity Gradual adjustment of the dimmer intensity from 0 to 100%	proportional

The ARCSPOT 170 RECESSED can be operated with a controller in **controller mode** or without the controller in **stand-alone mode**.

Both modes are described in the texts below.

7. Controller mode

The fixtures are individually addressed (001-497) on a data link and connected to the controller. The fixtures respond to the DMX signal from the controller.

7.1 DMX addressing

The control panel on the front side of the base allows you to assign the DMX fixture address, which is defined as the first channel from which the ARCSPOT 170 RECESSED will respond to the controller.

If you set, for example, the address to channel 5, the ARCSPOT 170 RECESSED will use the channel 5 to 16 for control (if mode 1 is selected).

Please, be sure that you don't have any overlapping channels in order to control each ARCSPOT 170 RECESSED correctly and independently from any other fixture on the DMX data link.

If two, three or more ARCSPOT 170 RECESSED are addressed similarly, they will work similarly.

For address setting, please refer to the instructions under "Addressing" (menu "**A001**").

Controlling:

After having addressed all ARCSPOT 170 RECESSED, you may now start operating these via your lighting controller.

Note: After switching on, the ARCSPOT 170 RECESSED will automatically detect whether DMX 512 data is received or not. If there is no data received at the DMX-input, the display will start to flash "**A001**" with actually set address.

This situation can occur if:

- the 3 PIN XLR plug (cable with DMX signal from controller) is not connected with the input of the ARCSPOT 170 RECESSED
- the controller is switched off or defective, the cable or connector is defective or the signal wires are swapped in the input connector.

Note: It's necessary to insert the XLR termination plug (with 120 Ohm) to the last fixture in the link in order to ensure proper transmission on the DMX data link.

7.2 Remotely controllable functions

Lamp

The ARCSPOT 170 RECESSED is to be operated with a CDM-SA/T150W/942 lamp.

A relay inside of the ARCSPOT 170 RECESSED allows you to switch on and off the lamp via the control panel or via your DMX-controller without affecting the rest of the lighting.

To switch On/Off the lamp, use the menu "**LAMP**" - please refer to "Switching On/Off the lamp".

Note: It is also important to note, that the discharge lamp is cold restrike types, that means, that they have to be cold before re-striking. For this reason, you have to wait 5 minutes (after having switched Off the lamp before you can switch it back On again. If you try to switch On the lamp within 5 minutes after having switched it Off, the ARCSPOT 170 RECESSED will store this information and automatically ignite the lamp when the 5 minutes period has expired. The message "**HEAT**" will appear on the control board display of the ARCSPOT 170 RECESSED. If the ignition of the lamp is seven times unsuccessful, on the display will appear "**LA.Er.**", meaning that the lamp could be damaged or even missed, or there could be a failure on the ignitor or ballast.

Colour - wheel

The ARCSPOT 170 RECESSED contains a colour wheel with 11 colour positions - 10 of these with dichroic colours and the last one white. All colours are interchangeable. The colour-wheel can be positioned between two adjacent colours in any position. It is also possible to rotate the colour-wheel continuously at different speeds ("Rainbow effect" in both directions).

Rotating gobo wheel

The rotating gobo-wheel includes 3 metal gobos, 3 glass gobos and 1 multicolor dichroic gobo rotating in both

directions, indexable. All gobos are interchangeable. The metal gobos have an outside diameter of 26.9 mm and an image diameter of 22.5 mm. The glass and dichroic gobos have an outside diameter of 26.8 mm and an image diameter of 22.5 mm.

Focus

Motorized focus enables the beam to be focused anywhere on the stage.

Shutter/Dimmer/Strobe

The dimming (0-100%) is provided by the simple mechanical shutter unit. This unit may also be used for strobe effect (1 - 8 flashes per second).

8. Stand - alone mode

The fixtures on a data link are not connected to the controller but can execute pre-set programs which can be different for every fixture. To set the program to be played, see the "Stand-alone setting" (menu "St.AL.").

"Stand-alone operation" can be applied to the single fixture (the fixture may be set to the master /slave mode or controller mode) or to multiple fixtures operating synchronously.

Synchronous operation of multiple fixtures requires that they must be connected on a data link and one of them is set as a master (master mode) and the rest as the slaves (slave mode). The slaves are assigned to SLA1-SLA9 and on the certain slave address can be connected only one fixture. To set the fixture as the master or slave , see the "Addressing" (menu "A001").

If the master fixture runs a reset or plays test(program) ,all slaves will execute these acts too.

You can't play or edit any programs on the slaves by their control panels if the master is switched on and connected to the master/slave chain.

The master fixture starts simultaneous program start in the other slave fixtures. All fixtures have a definite, synchronized starting point when playing back their programs. The number of running program is the same in all slaves and depends on the master's choice (menu "St.AL."). Every fixture runs its program repeatedly ,starting the program step No.1 when requested by the master .

For example:

If the slave fixture has a shorter program length, it will continuously repeat its program until the master fixture finishes its own program and restarts its program running (slave 1- prog.step 3 will not be finished).

If the slave fixture has a longer program length, it will restart at prog. step 1 before it completes all its prog.steps (slave 2 - prog.step 5 will not be played)- see the picture bellow.

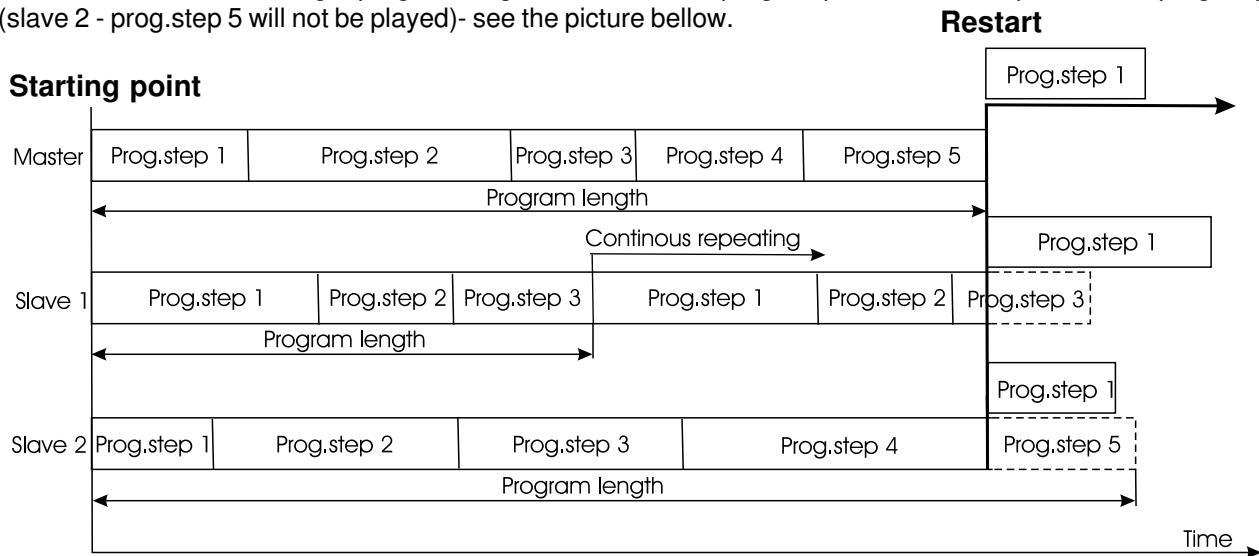

Note: Disconnect the fixtures from the DMX controller before master/slave operating , otherwise data collisions can occur and the fixtures will not work properly!

It's necessary to insert the XLR termination plug (with 120 Ohm) into the input of the master fixture and into the output of the last slave fixture in the data link in order to ensure proper transmission on the data link.

From the master's control panel is possible to control any slave in a master/slave chain.

9. Functions of the control panel

The control panel situated on the front side of the base offers several features. You can simply set the DMX address, master/slave mode, read the number of lamp or unit hours, run test, make a reset and also use many functions for setting and service purposes.

The main menu of the control panel is accessed by pressing the [↗] button - press this one so many times until the display shows message "A001" (with actually stored address). Browse through the menu by the pressing [▲] or [▼] buttons - the display shows step by step these messages: A001, SLct, InFO, PErS, LAMP, tESt, StAL, rESE, SPEC. Press [Enter] if you wish to select one of them. The functions are described in the following sections and the function hierarchy is shown below.

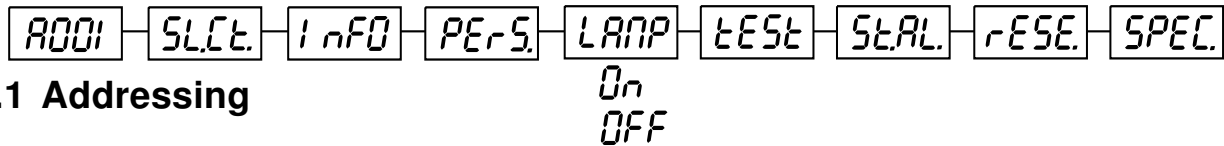

9.1 Addressing



By this menu you can set the DMX address or address the fixture as a master/slave.

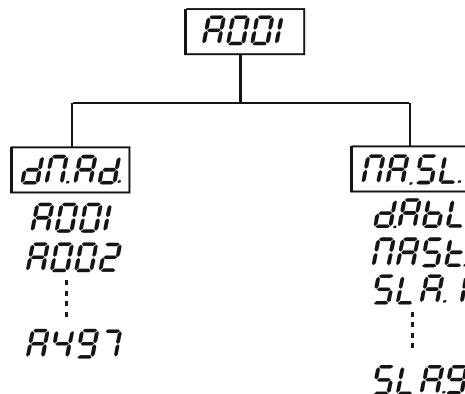

1. Press the [↗]- button so many times until the display shows message "A001" (with actually stored address).
 2. Press [↵]-button and use the [▲] and [▼] buttons to select "dM.Ad."-menu.
 3. Press [↵]-button (the letter "A" flashes) and by [▲] and [▼] buttons select required address (001-497), press [↵]-button to confirm.
 4. Select "M.ASL."-menu, press [↵]-button and use [▲] and [▼] buttons to select "d.AbL." (no master or slave), press [↵]-button to confirm.
 5. Press the [↗]- button. Chosen address is shown on the display.
- If message "A001" (with actually stored address) flashes - no DMX data received at the DMX-input.



1. Press the [Mode]- button so many times until the display shows message "A001" (with actually stored address).
 2. Press [↵]-button and use the [▲] and [▼] buttons to select "MA.SL."-menu.
 3. Press [↵]-button (display flashes) and select "MASt" (to set the fixture as the master in a chain of multiple fixtures) or "SLA.1"-"SLA.9" (to set the fixture to be the slave in a chain of multiple fixtures) and press [↵] to confirm. If you want address no master or slave, select "d.AbL.".
 4. Press the [↗]- button. Chosen address is shown on the display.
- If message "MASt." fast flashes - DMX signal is received at the DMX-input - disconnect DMX controller!

Only one fixture may be the master. Up to the 9 slaves may be connected to the master and on the certain address can be connected only one slave fixture (SLA1-SLA9).

Note: Disconnect the fixtures from the DMX controller before master/slave operating, otherwise data collisions can

occur and the fixtures will not work properly!

If the fixture is set as the master and DMX signal is connected to its input, the error message "MAEr" will appear on its display and the fixture's address will be set to its DMX address in order to respond to DMX signal from the controller.

For example:

The master fixture has this address setting: "dM.Ad."-menu.....**A013**

"MA.SL."-menu.....**MASt** (is displayed)

The DMX signal is connected to the master fixture. The message "**MASt**" starts fast flashing and after 20s error message "MA.Er" appears on its display and the fixture automatically will be switched to its DMX address (master address is disabled).

Now the fixture has the address setting: "dM.Ad."-menu.....**A013** ("A013"/" MA.Er"blinks)

"MA.SL."-menu.....**d.AbL.**

If the fixture is set as the slave and DMX signal is connected to its input, the fixture will respond to DMX signal from the controller (in dependence on the fixture's DMX address).

9.2 Slave control



This function allows you to control the slaves from the master's control panel in a master/slave operation.

Select this function from the main menu and press [↵]-button. Browse the list of all connected slaves ("SL.C.1" - "SL.C.9") by pressing [▲] and [▼] buttons. Select the desired slave and press [↵]-button. The slave's control panel is available from the master's control panel.

If no slave is connected to the master, messages "SL.C.1", "SL.C.2", "SL.C.3"... "SL.C.9" still round repeat.

Note: This function is available from the master fixture only.

9.3 Fixture informations



The menu allows you to read an useful information about the fixture as the lamp life, lamp strikes, software version, etc.

Press [▲] and [▼] buttons to select the desired option and press [↵] to see the value or next submenu.

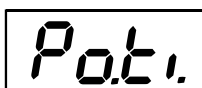
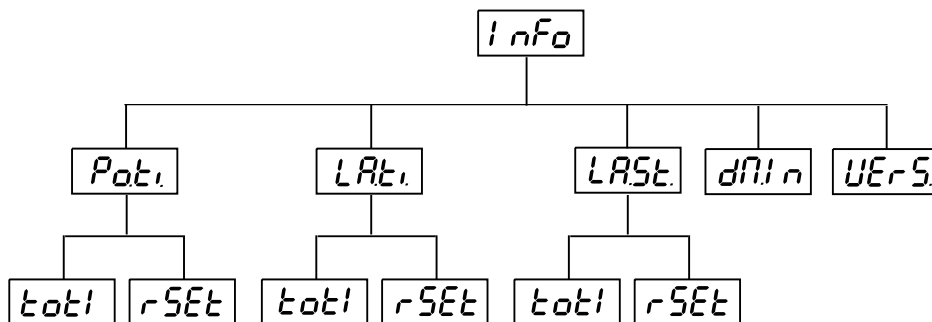

Power On time

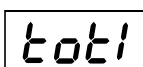

By this option you can read the total number of the operation hours since the

ARCSPOT 170 RECESSED has been fabricated. Press [↵] or [↶] to return to the menu.

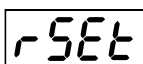

The number of the hours that the ARCSPOT 170 RECESSED has been powered on

since

the counter was last reset. Press [↵] or [↶] to return to the menu. In order to reset this counter to 0, you have to hold the [▲] and [▼]-button and press the

[↵]-button.

LAt. Lamp On time

totl - This option enables you to read the total number of the operation hours with the lamp on since the ARCSPOT 170 RECESSED has been fabricated. Press [↵] or [↗] to return to the menu.

rSEt - The number of hours that the lamp has been powered On since the counter was last reset. Press [↵] or [↗] to return to the menu. In order to reset this counter to 0, you have to hold the [▲] and [▼]-button and press the [↵]-button.

LASt. Lamp strikes

totl - By this option you can read the total number of the lamp strikes since the RECESSED SPOT 170 has been fabricated. Press [↵] or [↗] to return to the menu.

rSEt - The number of the lamp strikes since the counter was last reset. Press [↵] or [↗] to return to the menu. In order to reset the counter to 0, you have to hold the [▲] and [▼]-button and press the [↵]-button.

dM.in. - DMX values

Readout DMX values of each channel received by the fixture. Use the [▲] and [▼] buttons to select desired channel and press [↵] to read its value coming to the fixture or [↗] to cancel and return to the menu.

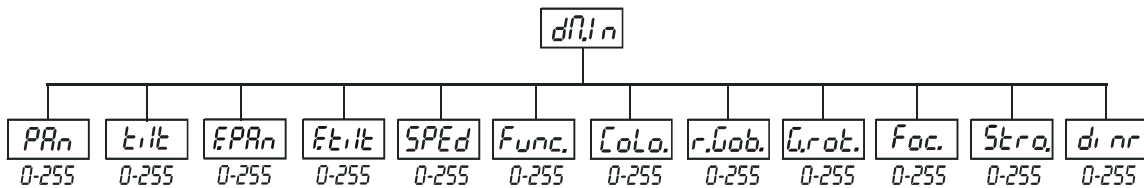

UErS. - Software version

By this function you can read the software version of the display module. Press [↵] to read its value or [↗] to return to the menu.

9.4 Personality options

PErS.

These options allow you to modify ARCSPOT 170 RECESSED operating behavior. Press [▲] and [▼] buttons to select the desired option and press [↵] to set the value or to see next submenu.

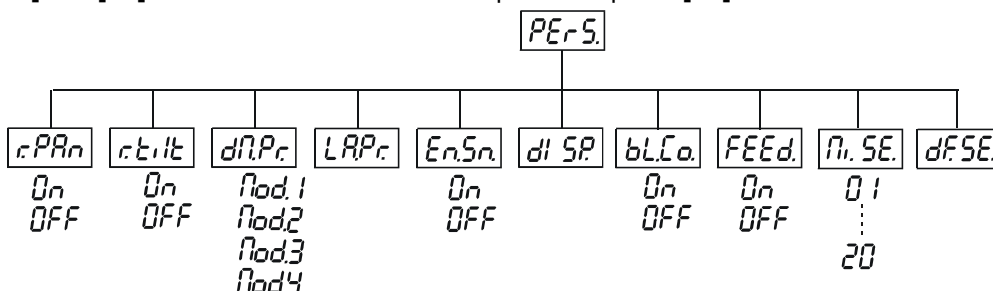

r.PAn - Pan reverse

This function allows you to invert the pan movement. Use the [▲] or [▼] buttons to select "On" if you wish this feature or "Off" if you don't wish this feature and press [↵] to confirm or [↻] to cancel and return to the menu.

r.tilt - Tilt reverse

This function allows you to invert the tilt movement. Use the [▲] or [▼] buttons to select "On" if you wish this feature or "Off" if you don't wish this feature and press [↵] to confirm or [↻] to cancel and return to the menu.

dM.Pc. - DMX presetting

The function makes possible to select from the 4 DMX- channels settings (including 8 or 16 bit movement resolution). Use the [▲] or [▼] buttons to select desired channel settings ("Mod.1,Mod.2,Mod.3,Mod.4") and press [↵] to confirm or [↻] to cancel and return to the menu.

List of the channels settings:

Channel	Mode 1 (default)	Mode 2	Mode 3	Mode 4
1	Pan	Pan	Pan	Pan
2	Tilt	Fine Pan	Tilt	Tilt
3	Fine Pan	Tilt	Speed	Fine Pan
4	Fine Tilt	Fine Tilt	Lamp on/off,reset	Fine Tilt
5	Speed	Speed	Colours	Speed
6	Lamp on/off,reset	Lamp on/off,reset	R.gobos	Lamp on/off,reset
7	Colours	Colours	Gobo rotation	Colours
8	R.gobos	R.gobos	Focus	No function
9	Gobo rotation	Gobo rotation	Shutter,strobe	No function
10	Focus	Focus	Dimmer	No function
11	Shutter,strobe	Shutter,strobe		R.gobos
12	Dimmer	Dimmer		Gobo rotation
13				No function
14				Focus
15				Shutter,strobe
16				Dimmer

Please refer to the chapter "DMX- protocol" for detail description.

LAPc. Lamp presetting

This function allows you to adjust the lamp settings:

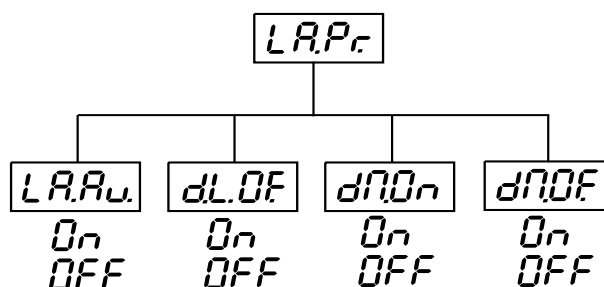

LAAu. Lamp On after switching the fixture On

This function enables to turn the lamp on automatically after switching the fixture on. Use the [▲] and [▼] buttons to select "On" if you wish to turn the lamp on automatically after switching the fixture on or "Off" if you wish the lamp off after switching on the fixture and press [↵] to confirm or [↻] to cancel and return to the menu.

dL.OF. Lamp Off via DMX

This function allows you to switch off the lamp by DMX. Use the [▲] and [▼] buttons to select "On" if you want to switch off the lamp by DMX or "Off" if you don't want to switch off the lamp by DMX and press [↵] to confirm or [↶] to cancel and return to the menu.

dN.On Lamp On if DMX is present

This function allows you to strike the lamp automatically after 26 seconds if DMX signal is present on the data link. If the ignition is unsuccessful (e.g. lamp is too hot), the fixture will try to ignite the lamp after next 26 s. This process will repeat until the lamp lights. Use the [▲] and [▼] buttons to select "On" if you want to strike the lamp or "Off" if you don't want to strike the lamp and press [↵] to confirm or [↶] to cancel and return to the menu.

dN.OF. Lamp Off if DMX is missing

This function allows you to switch Off the lamp automatically after 2 minutes if DMX signal is missing on the data link. Use the [▲] and [▼] buttons to select "On" if you want to switch Off the lamp or "Off" if you don't want to switch Off the lamp and press [↵] to confirm or [↶] to cancel and return to the menu.

En.Sn. Switch On/Off the lamp light sensor

Use the [▲] and [▼] buttons to select "On" if you wish to switch the lamp light sensor on and press [↵] to confirm or [↶] to cancel and return to the menu. **The option "On" is for the standard operation.** Use the [▲] and [▼] buttons to select "Off" if you wish to switch the lamp light sensor Off and press [↵] to confirm or [↶] to cancel and return to the menu.

Important: The option "Off" is for "emergency operation" only if the lamp light sensor is defective and you will wait for a service intervention! If the lamp light sensor is switched Off, the error messages "LAEr, SnEr, HEAt" will not appear on the display (only the message "HEAt" will appear if the lamp was turned off and on within 5 minutes) and at switching the lamp on the electronics will still try to ignite the lamp until it shines (even when the lamp is damaged or absent), on this account some electronics parts could be damaged!

dI SP. - Display adjusting

This function allows you to adjust the display settings:

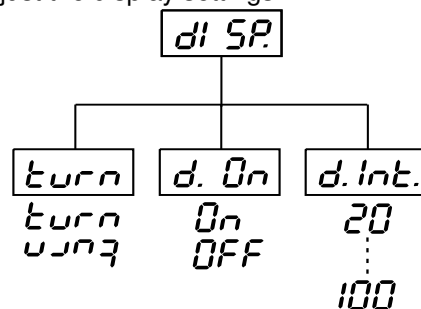

dI. nt. - Display -intensity

With this function you can adjust the display intensity from 20% to 100%. Use the [▲] or [▼] buttons to select the level of the display intensity and press [↵] to confirm or [↶] to cancel and return to the menu.

turn - Display-reverse

With this function, you can rotate the display by 180°. Use the [▲] or [▼] buttons to select "normal display" or "display turned by 180°" and press [↵] to confirm or [↶] to cancel and return to the menu.

d.On - Display-On

This function allows you to keep the display on or to turn off automatically 2 minutes after last pressing any button on the control panel. Use the [▲] or [▼] buttons to select "On" if you wish to keep the display on or "Off" if you wish to turn off automatically 2 minutes after last pressing any button on the control panel and press [↵] to confirm or [↶] to cancel and return to the menu.

- Blackout during movement correction

The function executes the blackout during the head movement correction (the moving head has lost its right pan/tilt-position for a short moment). Use the [▲] and [▼] buttons to select "On" if you want to execute the blackout or "Off" if you don't and press [↵] to confirm or [↶] to cancel and return to the menu.

- PAN/TILT-feedback

This function allows to return the moving head to the required pan/tilt position after changing the position by external force (e.g. by stroke). Use the [▲] and [▼] buttons to select "On" if you wish to enable this function or "Off" if you wish not to return the moving head to the required position and press [↵] to confirm or [↶] to cancel and return to the menu.

Note: If the feedback was switched off, the pan/tilt-position is changed by an external force and the feedback is switched on again, the moving head might not be synchronized with the DMX signal. You have to make a reset in order to synchronize the moving head with the DMX signal.

- Microphone -sensitivity

With this function you can adjust the microphone sensitivity from 1 (maximum) to 20 (minimum). Use the [▲] or [▼] buttons to select the level of the microphone sensitivity and press [↵] to confirm the chosen level or [↶] to cancel and return to the menu.

Example:

underexited

right level

(upper segment blinks via the bass rhythm)

overexited

df.se - Default settings

Press [↵] to reset all fixture personalities (not the adjusting functions) to the default values. On the display will appear "rSt" meaning that the fixture makes the reset. See the table of personality setting and their default positions.

Personality	Display	Default values (SHADED)
Pan reverse	rPAN	On
		OFF
Tilt reverse	rtilt	On
		OFF
DMX presetting	dNPr	nod1
		nod2
		nod3
		nod4
Lamp On after switch the fixture On	LAAU	On
		OFF
Lamp Off via DMX	dLOF	On
		OFF
Lamp On if DMX is present	dNOOn	On
		OFF
Lamp Off if DMX is missing	dNOF	On
		OFF
Blackout during mov. correction	bLCo	On
		OFF
Display-On	d On	On
		OFF
Display intensity	d Int	20 40 60 80 100
Display- reverse	turn	turn
		turn
PAN/TILT feedback	FEEd	On
		OFF
Switch On/Off the lamp light sensor	EnSn	On
		OFF
Music trigger	Aud1	On
		OFF
Microphone sensitivity	n, SE	01 02 03 04 05
		06 07 08 09 10
		11 12 13 14 15
		16 17 18 19 20

9.5 Switching On/Off the lamp



Press the [↵] button in order to access the main menu. Browse through the menu by pressing the [▲] and [▼] buttons until the display shows "LAMP". Confirm by pressing [↵] button.

Use the [▲] and [▼] buttons to select "On" to switch On the lamp and "Off" to switch Off the lamp and press [↵] to confirm or [↵] to cancel.

9.6 Test sequences

tEST.

This function allows you to run a special demo-test sequences without an external controller, which will show you some possibilities of using RECESSED SPOT 170. Press [▲] or [▼] keys to select the "Mod1" or "Mod2" sequences. The "Mod1" is suitable for projections on the wall, ceiling or ground without any head-movement, the "Mod2" uses all ARCSPOT 170 RECESSED functions and therefore is good for a complete introduction of the fixture. Select "Mod1" or "Mod2" by [▲] or [▼] buttons and press [↵]-button to confirm the choice. If the test program is running, messages "run/test" blink on the display.

If you want to pause the running program in the required position, press the [↵]-button (messages "PAUS"/" test" blink). To continue the program running, press the [↵]-button again.

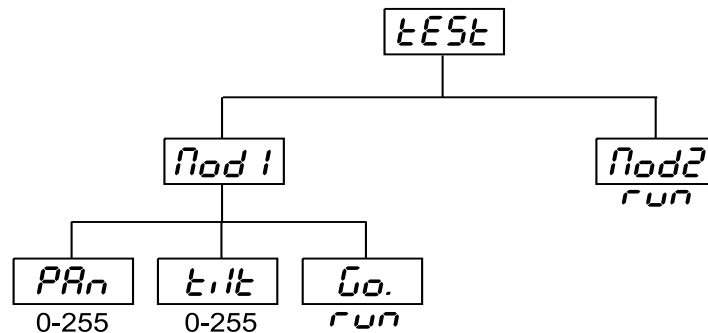

9.7 Stand-alone setting

St.AL.

This menu offers options for stand-alone mode as a selection of the playing program, programming and modifying current programs.

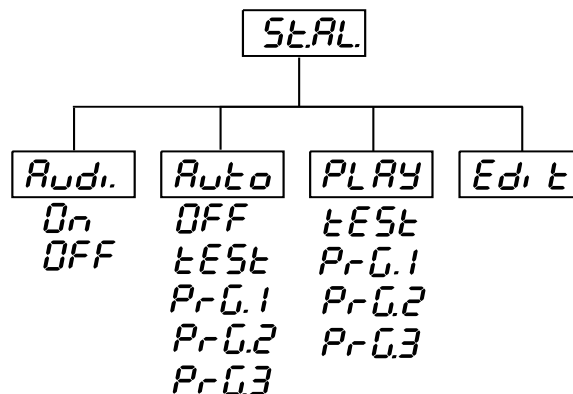

Audi - Music trigger

The ARCSPOT 170 RECESSED enables the sound control of the running programs via the built-in microphone. Use the [▲] or [▼] buttons to select "On" if you wish this feature or "Off" if you don't wish this feature and press [↵] to confirm or [↵] to cancel and return to the menu.

Auto - Presetting playback

This function allows you to select the the program which will be played in the stand-alone mode after switching

the fixture On. Use the [▲] or [▼] buttons to select desired program ("tEst" - built-in program) or "OFF" if you don't want trigger any program after switching the fixture On and press [↵] to confirm or [↴] to cancel and return to the menu. Selected program will be played continuously in a loop as long as it appears on the display.

This option should be set "OFF" for all slaves in the master/slave chain by reason of the right program starts.

For example: You have selected program "PrG.3" in this menu and:

this fixture is set as a single fixture (master/slave or controller operating)- the fixture will run its program "PrG.3".

this fixture is set as a master in a data chain- the fixture will run its program "PrG.3".

this fixture is set as a slave in a data chain- the fixture will run its program according to the master (if the master runs its own program "PrG.1", the slave will run its own program "PrG.1" also).

Note: If the fixture operates in the controller mode (DMX controller is connected) and any program from this menu is selected, in this case the fixture will not respond to the DMX controller after switching On and will play selected program.

PLAY - Playing program

This function allows you to run a built-in program "tEst" and the 3 freely-programmable programs "PrG.1, PrG.2, PrG.3". Press [▲] or [▼] buttons to select the desired program and press [↵] to run the program which will be played continuously in a loop.

If you want to pause the running program in the required position, press the [↵]-button (messages "PAUS"/"program No." blink). To continue the program running, press the [↵]-button again.

Note: If the fixture operates in the controller mode (DMX controller is connected) and any program from this function is selected in this case the fixture will not respond to the DMX controller and will play selected program.

You can't play programs on the slave fixtures from their control panels if the master fixture is switched On and connected to the slaves (playing is forced by the master).

Edi t. - Editing program

This menu item allows you to select a program to edit or create. The ARCSPOT 170 RECESSED has one built-in program ("tEst") and the 3 free programs, each up to 99 steps.

If the fixture is set as a master, then you may edit any program in the slaves. You can't edit programs on the slave fixtures from their control panels if the master fixture is switched on and connected to the slaves (editing is possible by the master control panel only).

Procedure:

1. Press [▲] or [▼]-button to select the program you want to edit ("PrG.1" - "PrG.3") and press [↵].
2. Press [▲] or [▼]-button to select the desired fixture ("MASt." - "SLA.9") and press [↵]-button.
3. Press [▲] or [▼]-button to select the desired program step ("St.01" - "St.99") and press [↵]-button.
4. Press [▲] or [▼]-button to select the desired item and press [↵]-button. Now you can edit by [▲] or [▼] buttons the DMX value for selected item:

"P.End." - a total number of the program steps, value 1-99. **This value you must set before start programming** (e.g. if you want to create program with the 10 steps, set P.End.=10).

"PAN" - a pan, value 0-255

"tilt" - a tilt, value 0-255

"F.PAN" - a fine pan, value 0-255

"F.tilt" - a fine tilt, value 0-255

"SPEd" - a speed of PAN/TILT movement, value 0-255

"Colo." - a colour, value 0-255

"r.Gob." - a rot.gobo, value 0-255

"G.rot." - a G.rotation, value 0-255

"Foc." - a focus, value 0-255

"Stro." - a strobe, value 0-255

"dimr" - a dimmer, value 0-255

"S.tim." - a step time, value 0, 1-25, 5 seconds

"COPY." - a copying the current prog. step to the next prog. step. If the last prog. step is copied to the next prog. step, parameter "P.End" is increased about 1 automatically (except step 99).

5. Press [↵]-button to confirm adjusted value.

6. Press [↴]-button, select next prog. step and repeat this procedure (steps 4 and 6).

The editing programs "PrG.1, PrG.2, PrG.3" are saved in the current modified fixture (master or slave 1-9).

Note: If you want to operate the programs in "Audio mode", set step time = 0.25s or higher and speed = 1 or higher to ensure the fluent pan/tilt movement.

9.8 Reset function

RESET.

Press [↵] button to run a reset. This option enables the ARCSLOT 170 RECESSED to index all effects (functions) and return to their standard positions.

9.9 Special functions

SPEC.

Use the [▲] or [▼] buttons to browse through the special functions and select the one by pressing [↵]-button.

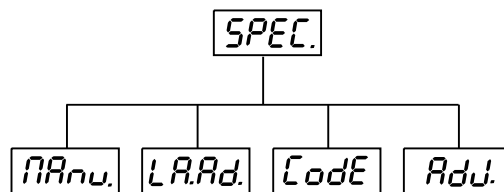

NAnu. - Manual control of effects

The function allows you to control manually the channel functions of the fixture. Use the [▲] or [▼] buttons to select desired function and press [↵] to adjust the effect or [↵] to cancel and return to the menu.

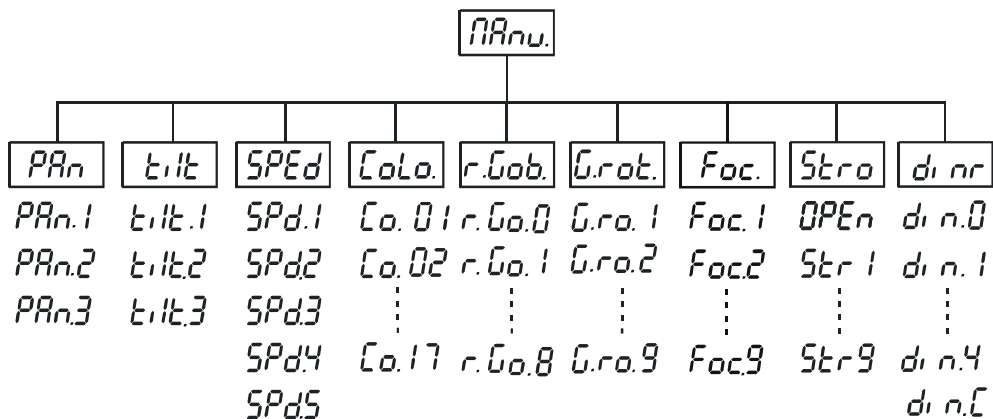

LAAd. - Lamp adjustment

This function can be used when you make the fine adjustment of the lamp. If you select "LAAd" pressing by [↵]-button, all effects will be canceled, shutter will be opened and the dimmer intensity will be set to maximum. By using the options "PAn, tilt, Foc" you can focus the light on a flat surface (wall) and perform the fine lamp adjustment.

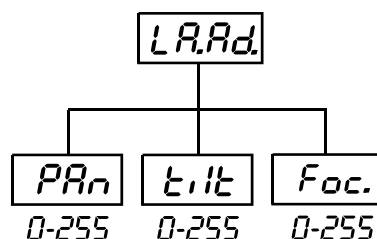

Code - Fixture code

The option contains identification code (1-9999) for the fixture, which is used for the master/slave operation.

Adj. - Adjusting the default positions of the colour and gobo wheels

By this function you can calibrate and adjust the colour and gobo wheels to their standard/right positions. Use the [▲] and [▼] buttons to browse through the adjusting menu - the display shows step by step these messages: "PAn, tilt,FPAn,FTilt,SPEd,Func,Colo,rGob,Grot,Foc,Stro, dimr, FCAL" by which you can adjust the fixture to the required/desired position (0-255) before the function calibration. Then when the positioning is finished use the last "F.CAL." function (Fixture calibration).

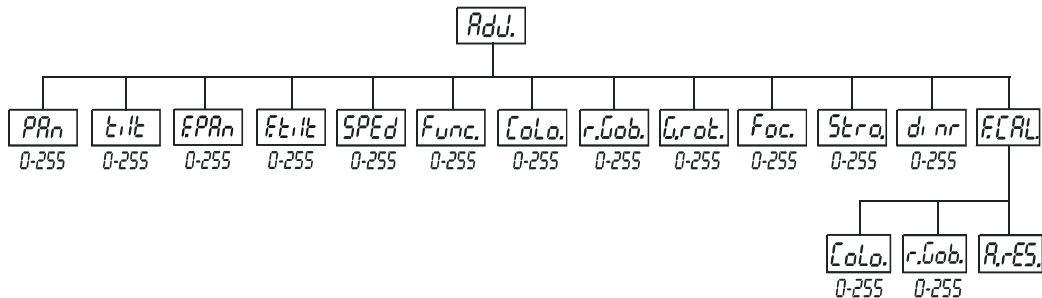

1. Calibration via the control panel

Press [↵] and the [▲] or [▼] buttons in order to display the following messages: "Colo, rGob," for very smooth function calibration. Select one of them, press [↵] and use the [▲] and [▼] buttons in order to adjust their right value from 0 to 255. Then press [↵] to confirm or [↵] to cancel and return to the menu. This can be repeated for each calibration parameter if it is required. When the calibration is finished, it is necessary to use the "A.rES." function in order to write the calibration values to the memory (EPROM) and to make a reset in order to check the newly adjusted positions of the colour and gobo wheels. When the reset of the fixture is finished, the display will show the "F.CAL." message. Press [↵] to repeat the calibration or [↵] to return to the "Adj." menu.

2. Calibration via the external controller

Use the 16-bit resolution (mode 1,2 or 4). Connect the DMX controller, press [↵] and the [▲] or [▼] buttons in order to display the following messages: "Colo, rGob," - calibration parameters. Select one of them and press [↵]. Now you can calibrate the colour and rotating gobo wheel by your controller. The DMX calibration protocol is described in the table mentioned below.

DMX Calibration protocol (for mode 1,2):

DMX Channel	1	2	3	4	5	6	7	8	9	10	11	12
	COLOUR	R. GOBO	-	-	-	-	COLOURS	R. GOBOS	G.ROTATION	FOCUS	STROBE	DIMMER
Function	CALIBRATION 0-255	CALIBRATION 0-255	-	-	-	-	STANDARD PROTOCOL	STANDARD PROTOCOL	STANDARD PROTOCOL	STANDARD PROTOCOL	STANDARD PROTOCOL	STANDARD PROTOCOL
	SMOOTH MICROSTEP MOVEMENT											

After having calibrated required functions press [↵] to confirm (or [↵] to cancel and return to the menu without reset by the "A.rES." function) and use the "A.rES." function in order to write the calibration values to the memory (EEPROM) and to make a reset in order to check the new adjusted positions of the colour and gobo wheels.

10. Error and information messages

M.b.Er.

This message informs you that the main PCB does not communicate correctly with the Control Panel.

Co.Er.

(Colour -wheel error) This message will appear after the reset of the fixture if the magnetic-indexing circuit malfunctions (sensor failed or magnet missing) or the stepping-motor is defective (or its driver circuit on the main PCB). The color-wheel is not located in the default position after the reset.

r.G.Er.

(Rotating gobo-wheel error) This message will appear after the reset of the fixture if the magnetic-indexing circuit malfunctions (sensor failed or magnet missing) or the stepping-motor is defective (or its driver circuit on the main PCB). The rotating gobo-wheel is not located in the default position after the reset.

i.G.Er.

(rotating gobo indexing error) The message will appear after the reset of the fixture and if the magnetic-indexing circuit malfunctions (sensor failed or magnet missing) or the stepping-motor is defective (or its driver circuit on the main PCB). The rotating gobo is not located in the default position after the reset.

Sn.Er.

This message appears if the lamp lighting sensor is failed.

HEAt

This message appears if you try to switch on the lamp within 5 minutes after having switched it off (the lamp is too hot). The message will appear on the display if the lamp doesn't ignite within 28 seconds. The fixture will store this information and automatically ignite the lamp when the 5 minutes period has expired.

Caution: The message is disabled if the lamp light sensor (function "En.Sn.") is switched Off (only if the lamp was turned Off and On within 5 minutes, the message "*HEAt*" will appear).

LA.Er.

The ignition of the lamp is seven times unsuccessful (the "*HEAt*" message appeared six times before), and the display shows "*LA.Er*", meaning that the lamp could be damaged or even missed, the fixture is overheating (this can occur if the ambient temperature is 40° C or more) or there could be a failure on the ignitor or ballast.

Please place or replace the lamp, check the ambient temperature or contact your dealer if the situation was not caused by the lamp.

Caution: The message is disabled if the lamp light sensor (function "En.Sn.") is switched Off.

Po.Er.

This message will appear if the fixture was shortly disconnect from the main.

PA.Er.

(Pan-yoke movement error) This message will appear after the reset of the fixture if the yoke's magnetic-indexing circuits malfunction (sensors failed or magnet missing) or the stepping motor is defective. (Or its driving IC on the main PCB). The yoke is not located in the default position after the reset.

ti.Er.

(TILT-head movement error) This message will appear after the reset of the fixture if the head's magnetic-indexing circuit malfunctions (sensor failed or magnet missing) or the stepping motor is defective. (Or its driving IC on the main PCB). The head is not located in the default position after the reset.

MA.Er.

(Master error) The message informs you that the fixture was addressed as a master and DMX signal is connected to its input. Disconnect the DMX controller from fixture's input and address the fixture as the master again.

Fr.Er.

This message will appear if the frequency of the main is not standard 50 or 60 Hz. This message can appear as a result of the interference during the lamp starting (if the lamp or igniter is old) or as a result of the interference by neighbouring devices. **In these cases the message does not affect the fixture operating!**

11. Technical specifications

Power supply:

EU-model:	208/230/240V AC, 50/60Hz ~
Fuse:	T 2.5A @ 230V
US-model:	100/120/208/230/240V AC, 50/60Hz ~
Fuse:	T 5.0A @120V
Power consumption:	300 VA

Lamp:

Philips CDM-SA/T150W/942, G12

Optical System:

- High luminous-efficiency parabolic system and 3 elements- objective
- All lenses are anti-reflection coated
- 19° beam angle

Beampath:

19° radiation angle

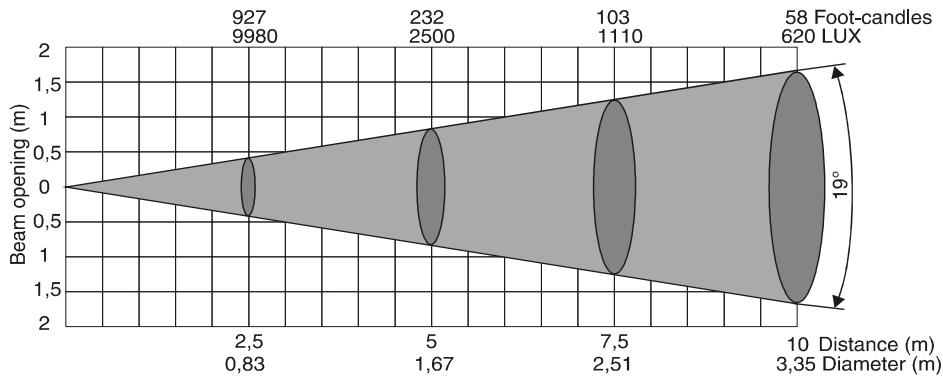

Colour-wheel

- 10 dichroic-filters plus white
- Colour-wheel with variable rotation speed
- All colour filters are interchangeable

Rotating gobos-wheel

- 3 metal gobos, 3 glass gobos and 1 dichroic gobo rotating in both directions at different speeds
- Gobo indexing
- Rotating gobo-wheel cont. rotation
- Metal gobos:outside diameter=26.9mm,image diameter=22.5mm,aluminium,thickness=0.5mm
- Multicolor dichroic gobo:outside diameter=26.8mm,thickness=1.1mm,high temperature borofloat or better glass
- Glass gobos:outside diameter=26.8mm,max.thickness=4mm,high temperature borofloat or better glass
- All rotating gobos are interchangeable

Focus:

- 19°-wide angle objective with the motorized focus

Strobe:

- Strobe effect with variable speed (1 - 10 flashes per second)

Shutter/Dimmer:

- Simple dimmer from 0 - 100 %

Motors:

- 7 high quality stepping-motors controlled by microprocessors

Fans:

- Two axial fans - one in the projector head and one in the base.

Electronics:

- master/slave operation(1 master + 9 slaves)
- 3 freely-programmable programs,each up to 99 steps
- built-in demo sequences
- sound control via built-in microphone
- Digital serial input DMX-512
- 4 DMX channel presettings (8 or 16-bit protocols):

Channel	Mode 1	Mode 2	Mode 3	Mode 4
1	Pan	Pan	Pan	Pan
2	Tilt	Fine Pan	Tilt	Tilt
3	Fine Pan	Tilt	Speed	Fine Pan
4	Fine Tilt	Fine Tilt	Lamp on/off,reset	Fine Tilt
5	Speed	Speed	Colours	Speed
6	Lamp on/off,reset	Lamp on/off,reset	R.gobos	Lamp on/off,reset
7	Colours	Colours	Gobo rotation	Colours
8	R.gobos	R.gobos	Focus	No function
9	Gobo rotation	Gobo rotation	Shutter,strobe	No function
10	Focus	Focus	Dimmer	No function

11	Shutter, strobe	Shutter, strobe	R.gobos
12	Dimmer	Dimmer	Gobo rotation
13			No function
14			Focus
15			Shutter, strobe
16			Dimmer

Pan/Tilt:

- Pan movement range 530°
- Tilt movement range 280°
- Automatic Pan / Tilt position correction
- Maximum PAN-movement 530° in 2,2 s
- Maximum TILT-movement 280° in 1.6 s

Rigging:

- Ceiling box for 600x600 or 625x625 mm grid mounting or version for plaster-boards
- Integral attachment points for wire hangers or all-thread support

Temperatures:

- Maximum ambient temperature t_a : 40° C
- Maximum housing temperature t_b (steady state): 80° C

Minimum distances:

- Min.distance from flammable surfaces: 0.5m
- Min.distance to lighted object: 0.8m

Weight -moving head:

- EU version: 11 kg
- US version: 13.5 kg

Weight -ceiling box:

7.0 kg

Dimensions (mm)-ceiling box is version for 600x600mm mounting grid:

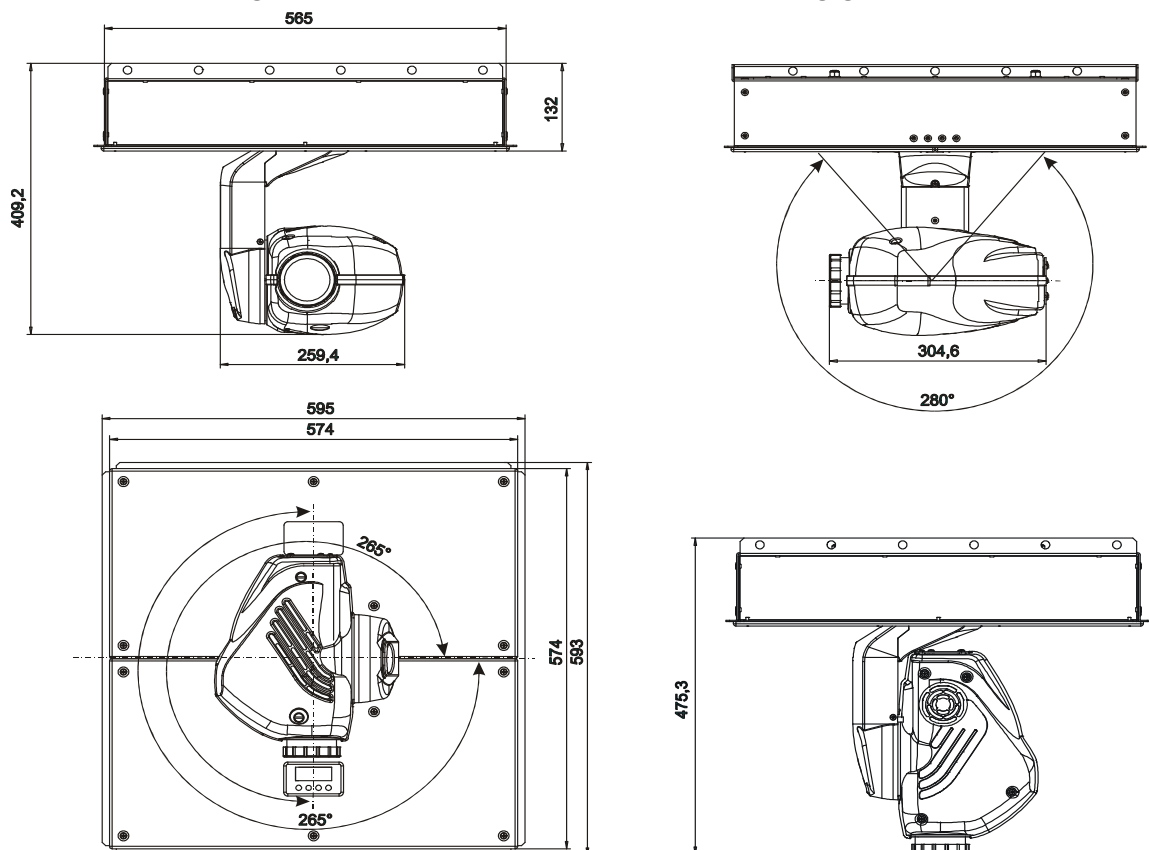

Accessories:

gobo-set 8.....15050017

12. Maintenance and cleaning

The operator has to make sure that safety-relating and machine-technical installations are inspected by an expert after every four years in the course of an acceptance test.

The operator has to make sure that safety-relating and machine-technical installations are inspected by a skilled person once a year.

The following points have to be considered during the inspection:

- 1) All screws used for installing the devices or parts of the device have to be tightly connected and must not be corroded.
- 2) There must not be any deformations on housings, fixations and installation spots (ceiling, suspension, trussing).
- 3) Mechanically moved parts like axles, eyes and others must not show any traces of wearing (e.g. material abrading or damages) and must not rotate with unbalances.
- 4) The electric power supply cables must not show any damages, material fatigue (e.g. porous cables) or sediments. Further instructions depending on the installation spot and usage have to be adhered by a skilled installer and any safety problems have to be removed.

DANGER TO LIFE !
***Isolate the fixture from AC power before starting
maintenance operation!***

It is absolutely essential that the fixture is kept clean and that dust, dirt and smoke-fluid residues must not build up on or within the fixture. Otherwise, the fixture's light-output will be significantly reduced. Regular cleaning will not only ensure the maximum light-output, but will also allow the fixture to function reliably throughout its life.

Please use a moist, lint-free cloth. Never use alcohol or solvents!

The front objective lens will require weekly cleaning as smoke-fluid tends to building up residues, reducing the light-output very quickly. The cooling-fans should be cleaned monthly.

The gobos may be cleaned with a soft brush. The interior of the fixture should be cleaned at least annually using a vacuum-cleaner or an air-jet.

The dichroic colour-filters, the gobo-wheel and the internal lenses should be cleaned monthly.

To ensure a proper function of the gobo-wheel we recommend lubrication in six month intervals. The quantity of oil must not be excessive in order to avoid that oil runs out when the gobo-wheel rotates.

There are no serviceable parts inside the device except for the lamp and the fuse. Maintenance and service operations are only to be carried out by authorized dealers.

Please refer to the instructions under "Fitting/Exchanging the lamp".

Replacing the fuse

If the lamp burns out, the fine-wire fuse of the device might fuse, too. Only replace the fuse by a fuse of same type and rating.

Before replacing the fuse, isolate the fixture from AC power!

Procedure:

Step 1: Remove the mounting box cover (cover without display) by loosening the 7 fixative screws.

Step 2: Unscrew the fuse holder on the power panel in the moving head's base with a fitting screwdriver from the housing (anti-clockwise).

Step 3: Remove the old fuse from the fuse holder.

Step 4: Install the new fuse in the fuseholder.

Step 5: Replace the fuse holder in the housing and fix it.

Step 6: Fix back the mounting box's cover.

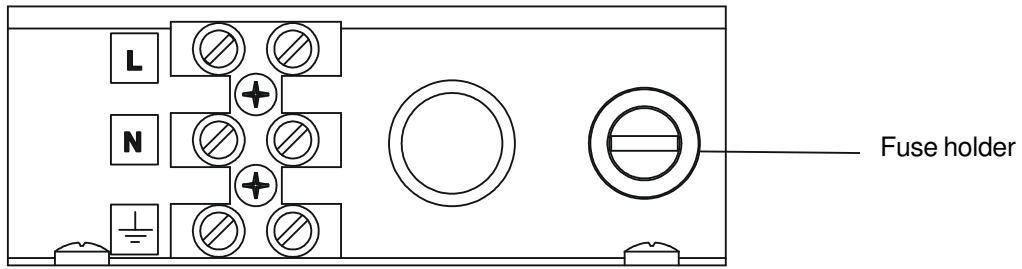

Should you need any spare parts, please use genuine parts.

If the power supply cable of this device will be damaged, it has to be replaced by authorized dealers only in order to avoid hazards.

Should you have further questions, please contact your dealer.

13. Appendix 1 - Menu map

Menu Level 1	Menu Level 2	Menu Level 3	Menu Level 4	Menu Level 5	Menu Level 6	DESCRIPTION	
A001	dM.Ad.	A001-A497				DMX addressss	
	MA.SL.	d.Abl.				Disable master/slave	
		MASt.					Set fixture as a master
		SLA.1-SLA9				Slave address	
SL.Ct.	SL.C.1-SL.C.9					Select slave for remote control	
InFo	Po.ti.	totl				Total hours of operation since fabricated	
		rSEt				Hours of operation since counter reset	
	La.ti.	totl				Total hours of lamp operation since fabricated	
		rSEt				Lamp hours since counter reset	
	LA.St.	totl				Total number of lamp strikes since fabricated	
		rSEt				Number of lamp strikes since counter reset	
	dM.In.	Pan	0-255				View DMX pan position value
		tilt	0-255				View DMX tilt position value
		F.Pan	0-255				View DMX fine pan position value
		F.tilt	0-255				View DMX fine tilt position value
		SPED	0-255				View DMX pan/tilt speed value.
		Func.	0-255				View DMX lamp on/off,reset value
		Colo.	0-255				View DMX colour -wheel position value
		r.Gob.	0-255				View DMX rotating gobo-wheel position value
		G.rot.	0-255				View DMX rot.gobo rotation value
		Foc.	0-255				View DMX focus lenses position value
		Stro.	0-255				View DMX strobe value
dimr	0-255				View DMX dimmer position value		
VERs						Software version	
PErS	r.PAN	On				Set pan invert ON	
		OFF				Set pan invert OFF	
	r.tilt	On				Set tilt invert ON	
		OFF				Set tilt invert OFF	
	dM.Pr.	Mod.1					Mode1 (16 bit movement resolution)
		Mod.2					Mode2 (16 bit movement resolution)
		Mod.3					Mode3 (8 bit movement resolution)
		Mod.4					Mode4 (16 bit movement resolution)
	LA.Pr.	LA.Au.	On				Lamp automatic. ON after switching fixture on
			OFF				No automatic lamp strike
		d.L.OF.	On				Enable lamp OFF via DMX command
			OFF				Disable lamp OFF via DMX command
	dM.On	On				Lamp automatically ON if DMX is present	
		OFF				Lamp will remain OFF if DMX is present	
	dM.OF.	On				Lamp automatically OFF if DMX is missing	
		OFF				Lamp will remain ON if DMX is missing	
	EN.Sn.	On					Enable lamp light sensor
OFF						Disable lamp light sensor	
diSp.	turn	normal				Normal LED display	
		inverted				LED display turned by 180°	
	d.On	On				Display permanent on	
		OFF				Display turns off 2 min. after last key press	
d.Int.	20,40,60,80,100				Set display intensity [%]		
bL.Co	On					Enable blackout during pan/tilt mov. correction	
	OFF					Disable blackout during pan/tilt mov. correction	
FEEd.	On					Enable pan/tilt feedback	
	OFF					Disable pan/tilt feedback	
Mi.SE.	1..10..20					Set microphone sensitivity	
dF.SE.						Return all personality options to factory defaults	

Menu Level 1	Menu Level 2	Menu Level 3	Menu Level 4	Menu Level 5	Menu Level 6	DESCRIPTION	
LAMP	On					Lamp power ON	
	OFF					Lamp power OFF	
tEst	Mod.1	Pan	0-255			Select pan value for demo running	
		tilt	0-255			Select tilt value for demo running	
		Go	run			Run demo without any head movement	
	Mod.2	run				Run demo with head movement	
St.Al.	Audi	On				Enable the sound control of the run. programs	
		OFF				Disable the sound control of the run.programs	
	Auto	OFF				No program runs after switching fixture on	
		tEst				Test program runs after switching fixture on	
		PrG.1				Program No.1 runs after switching fixture on	
		PrG.2				Program No.2 runs after switching fixture on	
		PrG.3				Program No.3 runs after switching fixture on	
	PLAy	tEst	run			Test runs in loop	
		PrG.1	run			Program No.1 runs in loop	
		PrG.2	run			Program No.2 runs in loop	
		PrG.3	run			Program No.3 runs in loop	
	Edit	PrG.1- PrG.3		MASt.- SLA.9 (only if Master is selected)	P.End	1-99	Set a total number of the program steps
					Pan	0-255	Set DMX value for pan
					tilt	0-255	Set DMX value for tilt
					F.Pan	0-255	Set DMX value for fine pan
					F.tilt	0-255	Set DMX value for fine tilt
					SPEd	0-255	Set DMX value for speed of pan/tilt mov.
					Colo.	0-255	Set DMX value for colour
					r.Gob.	0-255	Set DMX value for rotating gobo
					G.rot.	0-255	Set DMX value for rotating of rot.gobo
Foc.					0-255	Set DMX value for focus	
Stro.					0-255	Set DMX value for strobe	
dimr					0-255	Set DMX value for shutter	
S.tim					0,1-25,5	Set step time [sec.]	
COPY		Copying current prog.step to next step					
rESE						Run a reset	
SPEC.	Manu.	PAn	Pan.1- Pan.3			Select presetting pan position	
		tilt	tilt.1-tilt.3			Select presetting tilt position	
		SPEd	SPd.1- SPd.5			Select presetting speed of pan/tilt movement	
		Colo.	Co.01- Co.17			Select presetting colour -wheel position	
		r.Gob.	r.Go.0- r.Go8			Select presetting rot.gobo-wheel position	
		G.rot	G.ro.1- G.ro.9			Select presetting rot.gobo rotation	
		Foc.	Foc.1- Foc.9			Select presetting focus position	
		Stro.	OPEn,Str. 1-Str.9			Select presetting strobe position	
		dimr	dim.0- dim.C			Select presetting dimmer position	
	LAAd	Pan	0-255			Select pan position for lamp adjustment	
		tilt	0-255			Select tilt position for lamp adjustment	
		Foc.	0-255			Select focus position for lamp adjustment	

Menu Level 1	Menu Level 2	Menu Level 3	Menu Level 4	Menu Level 5	Menu Level 6	DESCRIPTION	
SPEC. (cont.)	Code					Fixture code	
	AdJ.	Pan	0-255				Select DMX value for pan position
		tilt	0-255				Select DMX value for tilt position
		F.Pan	0-255				Select DMX value for fine pan position
		F.tilt	0-255				Select DMX value for fine tilt position
		SPEd	0-255				Select DMX value for speed of pan/tilt
		Func.	0-255				Select DMX value for lamp on/off,reset
		Colo.	0-255				Select DMX value for colour-wheel pos.
		r.Gob.	0-255				Select DMX value for rot. gobo-wheel pos.
		G.rot.	0-255				Select DMX value for rot.gobo rotation
		Foc.	0-255				Select DMX value for focus lenses position
		Stro.	0-255				Select DMX value for strobe
		dimr	0-255				Select DMX value for shutter position
	F.CAL	Colo.		0-255			Calibrate colour-wheel to required position
		r.Gob.		0-255			Calibrate rot.gobo-wheel to required pos.
A.rES						Save calibration values to memory,reset	

Bold print=Default settings

14. Appendix 2 -Changing the power supply settings

Both the transformer and the ballast must be connected correctly for the local AC voltage and frequency. The wrong settings can cause poor performance or damage of the moving head. The factory settings are printed on the label on the bottom of the moving head base.

If you want to change the power supply settings, follow the instructions:

1. Disconnect the fixture from AC power.
2. Remove the ceiling box covers by loosening the 14 screws.
3. Move the wire ① on the transformer connection block to the position according to the desired voltage.
4. Move the wire ② on the ballast connection block to the position according to the desired frequency (voltage).
5. Close the ceiling box before applying AC power.

Examples:

EU-version

Power supply settings: 230V/50Hz

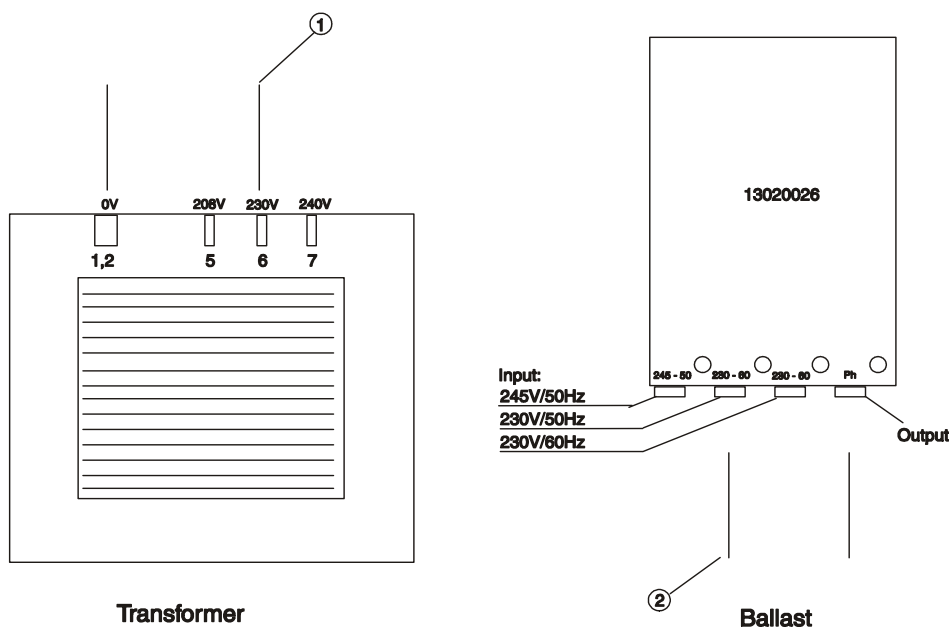

US-version

Power supply settings: 120V/60Hz

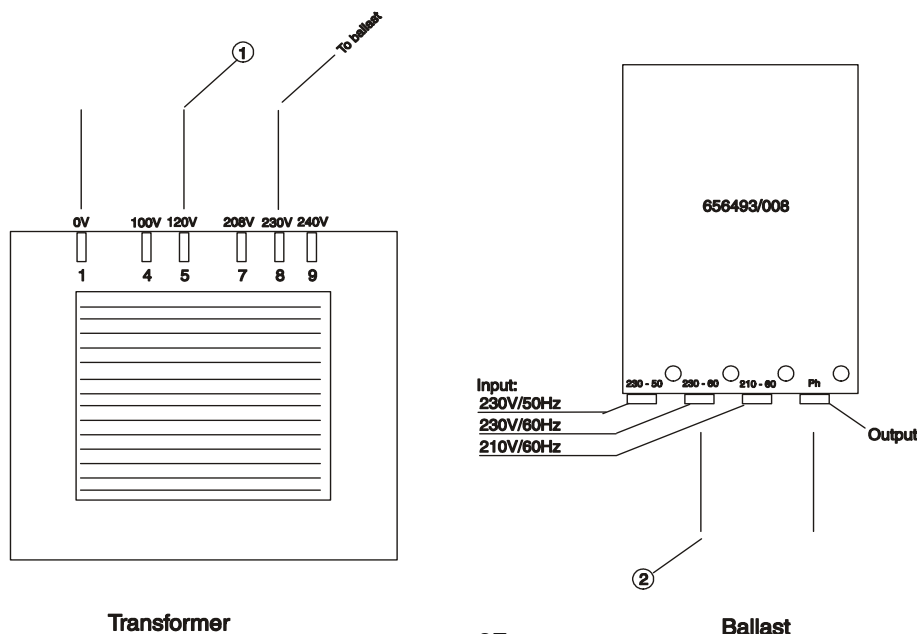

15. Appendix 3 -Box versions and dimensions

Version for 600x600mm mounting grid

Ceiling box
99010551

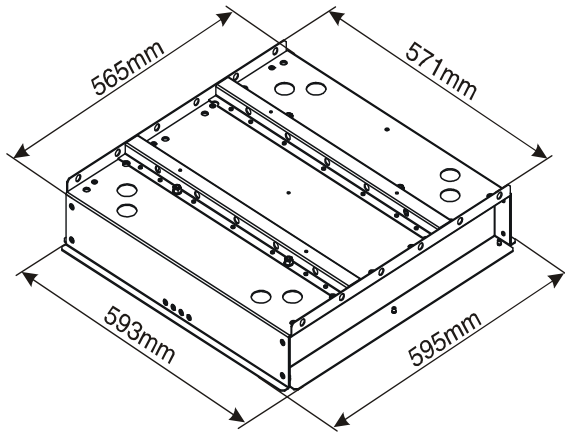

Box covers
19010084 19010083

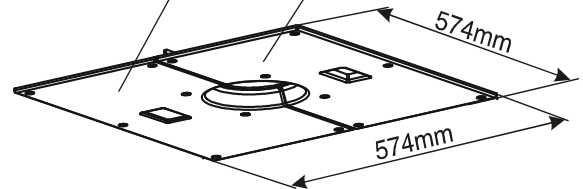

Installation

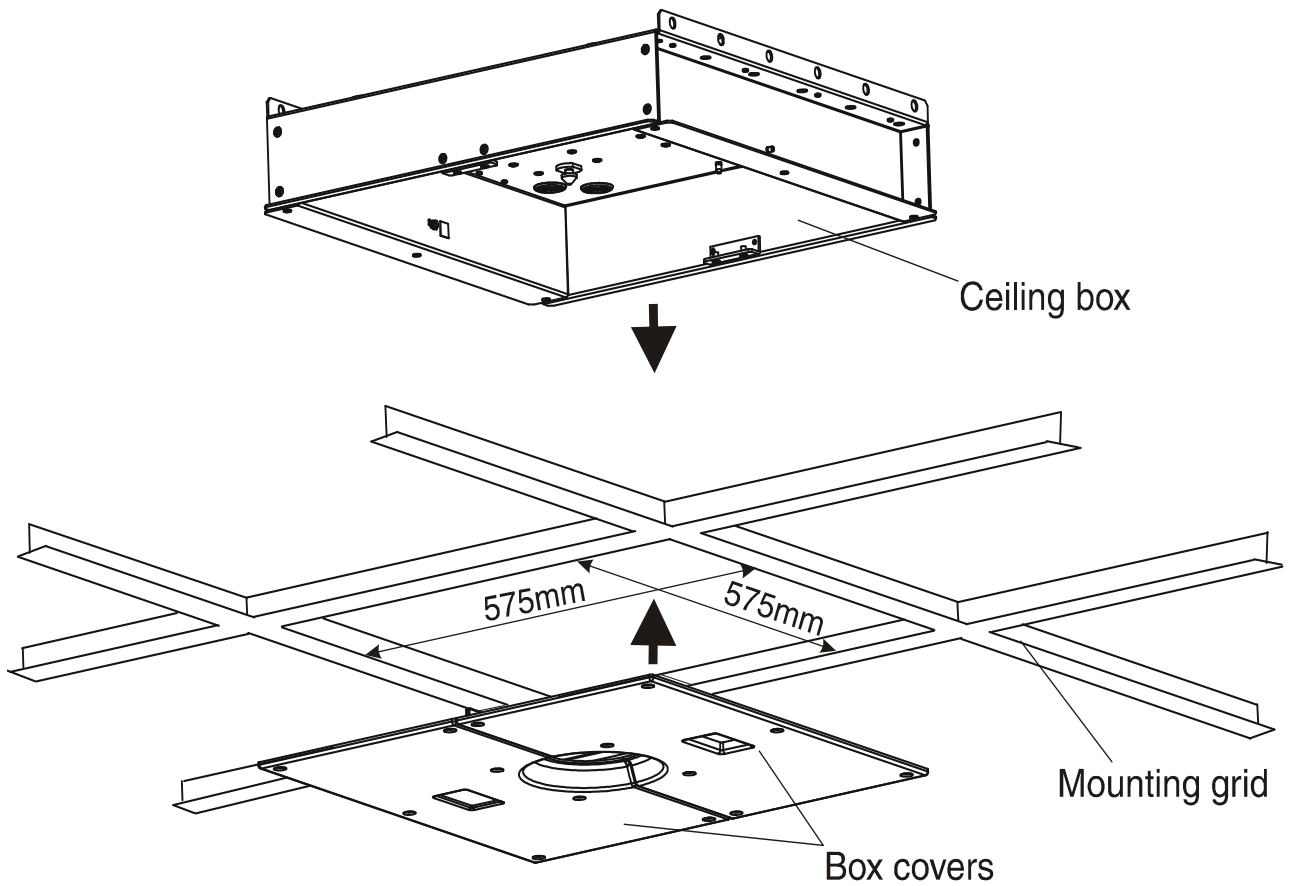

Version for 625x625mm mounting grid

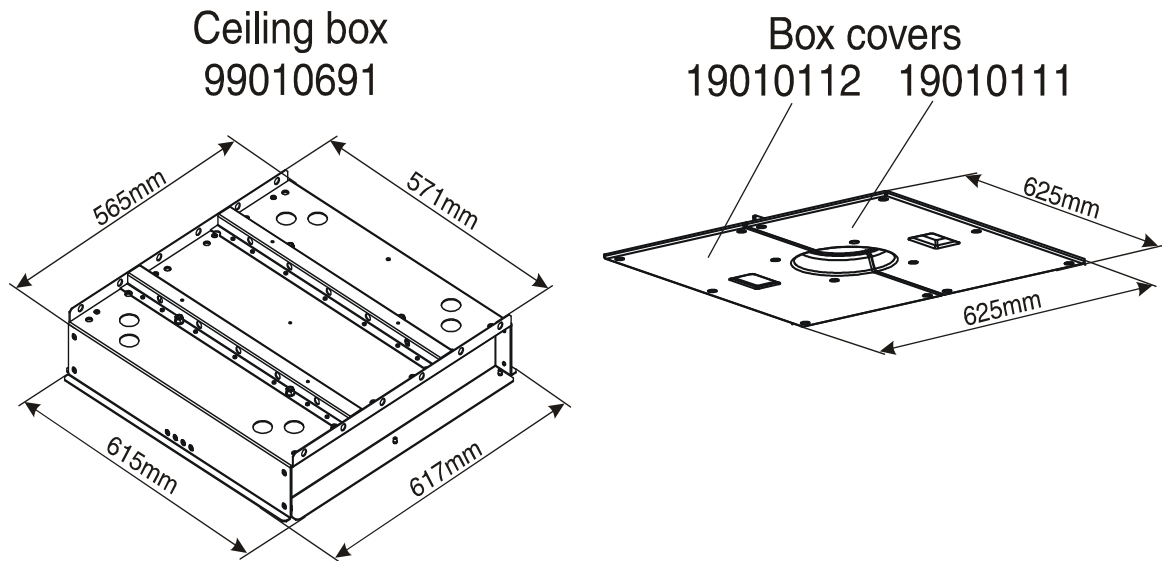

Installation

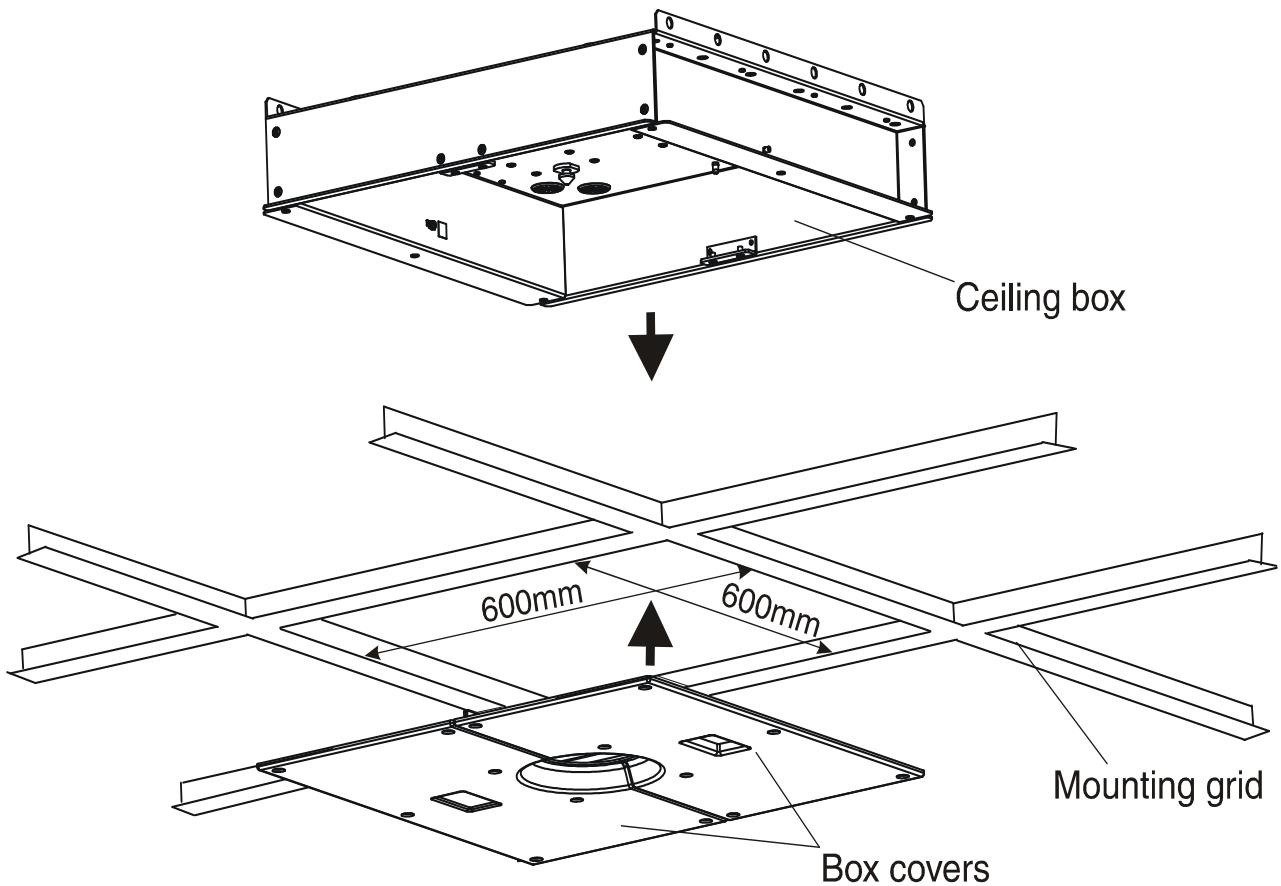

Version for lower ceiling from plaster-boards

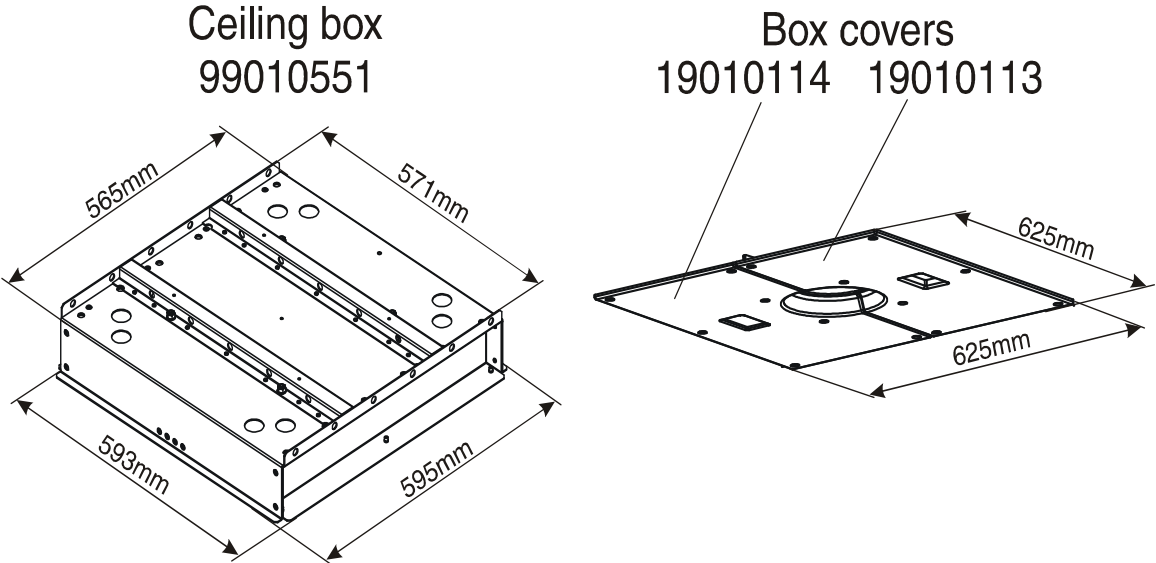

Installation

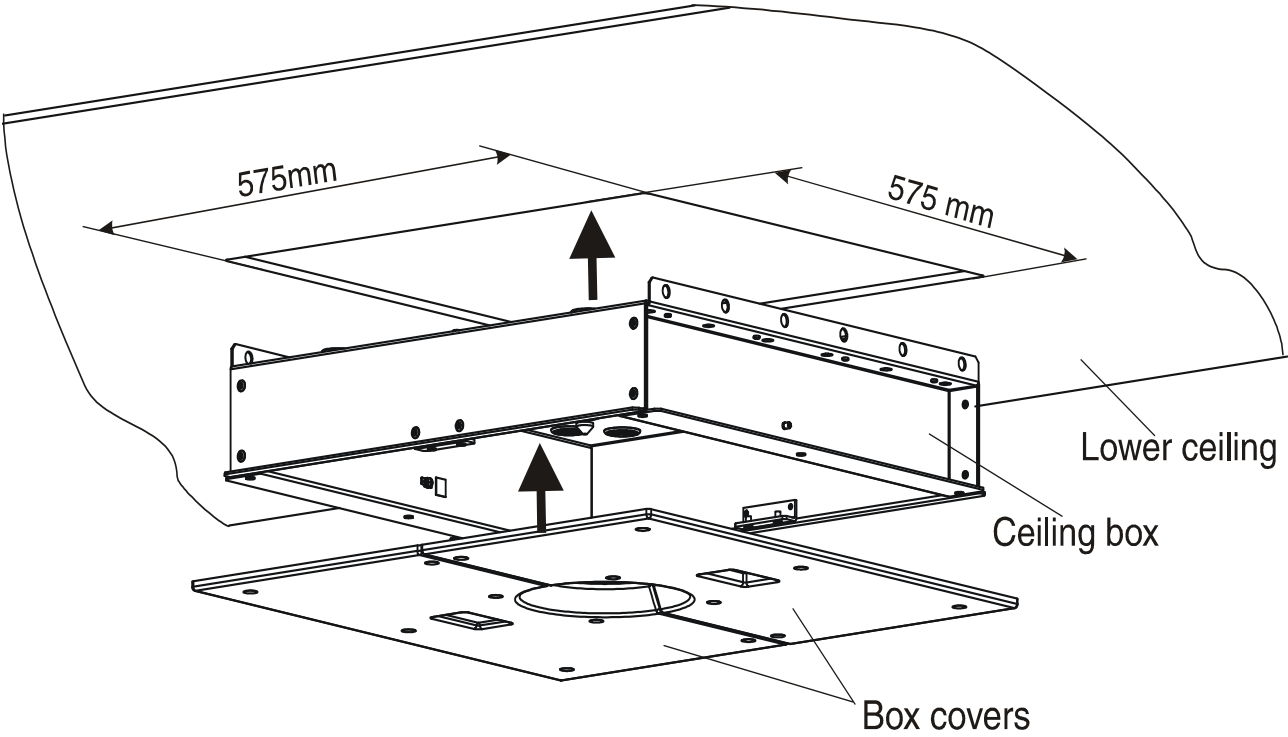

Ceiling box No.99010551

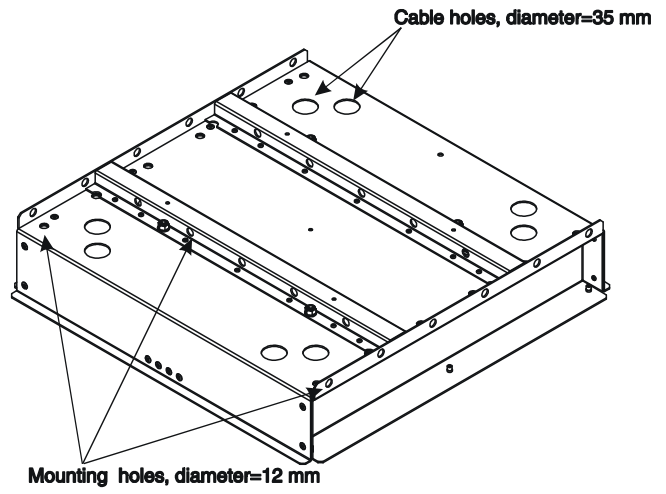
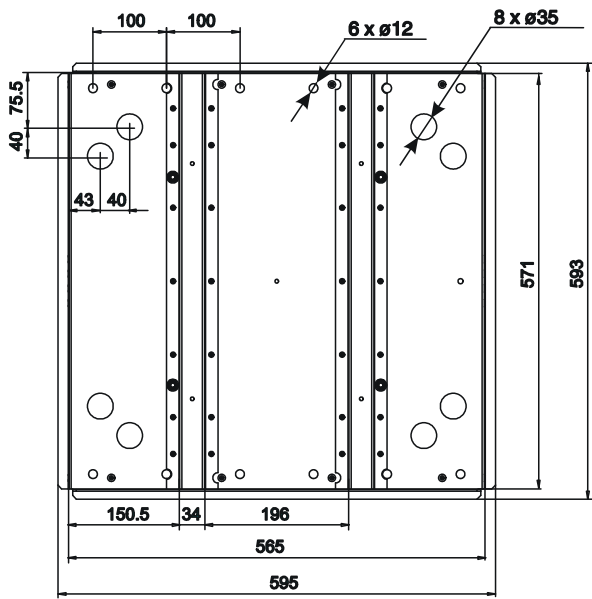
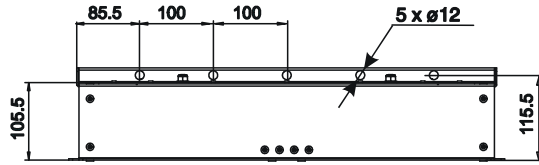
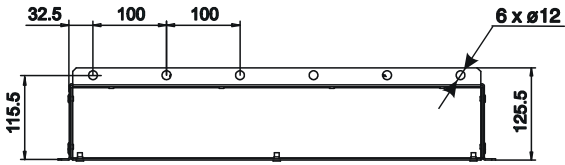

All dimensions are in mm

Ceiling box No.99010691

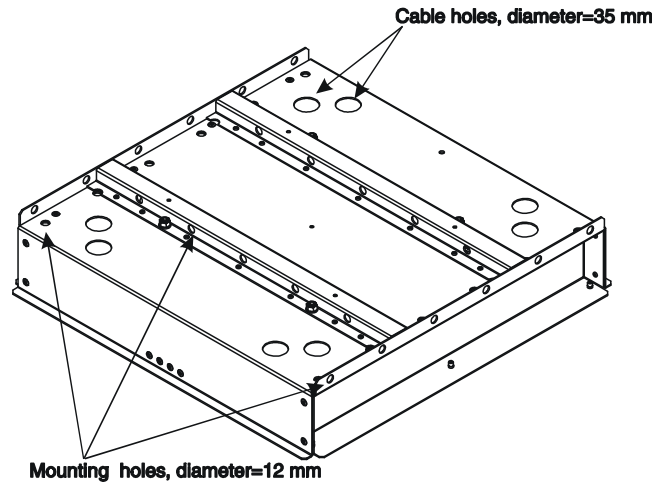
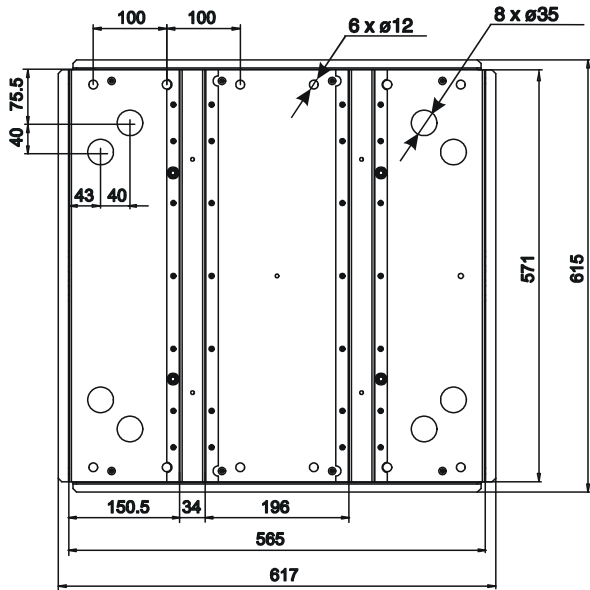
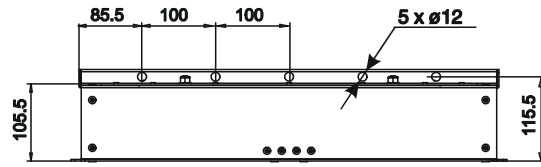
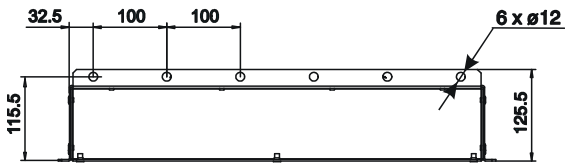

All dimensions are in mm

