

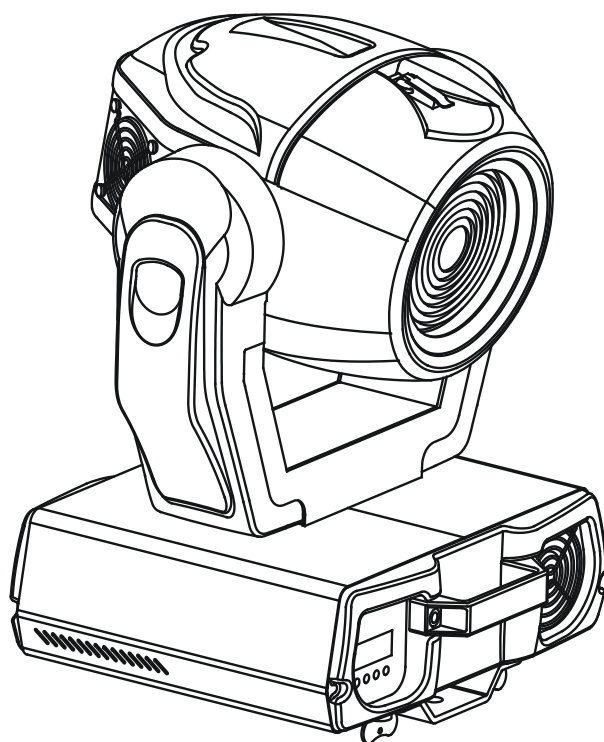

ClubWash 300ST



ROBE

USER MANUAL

Version 1.2

ClubWash 300 CT

Table of contents

1. Safety instructions	3
2. Operating determinations	4
3. Description of the device	5
4. Installation	6
4.1 Fitting the lamp	6
4.2 Lamp adjustment	7
4.5 Connection to the mains	7
4.6 Changing the power supply settings-magnetic ballast	7
4.7 Manual zoom	9
4.7 Rigging the fixture	10
4.8 DMX-512 connection/connection between fixtures	13
5. ClubWash 300 CT-DMX Protocol-version 1.0	14
6. Controller mode	16
6.1 DMX addressing	16
6.2 Remotely controllable functions	16
7. Stand - alone mode	17
8. Control menu map	18
9. Control menu	20
9.1 Fixture Address	20
9.2 Slave control	20
9.3 Fixture informations	20
9.4 Personality	21
9.5 Lamp On/Off	22
9.6 Test sequences	22
9.7 Stand-alone setting	23
9.8 Reset function	23
9.9 Special functions	24
10. Error and information messages	25
11. Technical specifications	26
12. Maintenance and cleaning	28

CAUTION!
Keep this device away from rain and moisture!
Unplug mains lead before opening the housing!

**FOR YOUR OWN SAFETY, PLEASE READ THIS USER MANUAL CAREFULLY
BEFORE YOU INITIAL START - UP!**

1. Safety instructions

Every person involved with installation and maintenance of this device have to:

- be qualified
- follow the instructions of this manual

CAUTION!
Be careful with your operations.
With a high voltage you can suffer
a dangerous electric shock when touching the wires!

This device has left our premises in absolutely perfect condition. In order to maintain this condition and to ensure a safe operation, it is absolutely necessary for the user to follow the safety instructions and warning notes written in this manual.

Important:

The manufacturer will not accept liability for any resulting damages caused by the non observance of this manual or any unauthorized modification to the device.

Please consider that damages caused by manual modifications to the device are not subject to warranty.

Never let the power cord come into contact with other cables! Handle the power cord and all connections with the mains with particular caution!

Make sure that the available voltage is not higher than stated on the rear panel.

Always plug in the power plug least. Make sure that the power switch is set to OFF-position before you connect the device to the mains. The power plug has to be accessible after installing the device.

Make sure that the power cord is never crimped or damaged by sharp edges. Check the device and the power cord from time to time.

Always disconnect from the mains, when the device is not in use or before cleaning it. Only handle the power-cord by the plug. Never pull out the plug by tugging the power cord.

This device falls under protection class I. Therefore it is essential to connect the yellow/green conductor to earth.

The electric connection, repairs and servicing must be carried out by a qualified employee. Do not connect this device to a dimmer pack.

Do not switch the fixture on and off in short intervals as this would reduce the lamp's life.

During the initial start-up some smoke or smell may arise. This is a normal process and does not necessarily mean that the device is defective.

Do not touch the device's housing bare hands during its operation (housing becomes hot)! For replacement use lamps and fuses of same type and rating only.

CAUTION ! EYEDAMAGES !
Avoid looking directly into the light source
(meant especially for epileptics) !

2. Operating determinations

This device is a moving-head for creating decorative effects and was designed for indoor use only.

If the device has been exposed to drastic temperature fluctuation (e.g. after transportation), do not switch it on immediately. The arising condensation water might damage your device. Leave the device switched off until it has reached room temperature.

Never run the device without lamp!

Do not shake the device. Avoid brute force when installing or operating the device.

Never lift the fixture by holding it at the projector-head, as the mechanics may be damaged. Always hold the fixture at the transport handles.

When choosing the installation-spot, please make sure that the device is not exposed to extreme heat, moisture or dust. There should not be any cables lying around. You endanger your own and the safety of others!

The minimum distance between light-output and the illuminated surface must be more than 1.3 meters.

Make sure that the area below the installation place is blocked when rigging, derigging or servicing the fixture.

Always fix the fixture with an appropriate safety-rope. Fix the safety-rope at the correct holes only.

Only operate the fixture after having checked that the housing is firmly closed and all screws are tightly fastened.

The lamp must never be ignited if the objective-lens or any housing-cover is open, as discharge lamps may explode and emit a high ultraviolet radiation, which may cause burns.

The maximum ambient temperature must never be exceeded. Otherwise, the lamp is switched off and the fixture is out of operation for 5 minutes.

CAUTION!
***The lens has to be replaced when it is obviously damaged,
so that its function is impaired, e. g. due to cracks or deep scratches!***

Operate the device only after having familiarized with its functions. Do not permit operation by persons not qualified for operating the device. Most damages are the result of unprofessional operation!

CAUTION!
***The lamp has to be replaced when it is damaged
or deformed due to the heat!***

Please use the original packaging if the device is to be transported.

Please consider that unauthorized modifications on the device are forbidden due to safety reasons!

If this device will be operated in any way different to the one described in this manual, the product may suffer damages and the guarantee becomes void. Furthermore, any other operation may lead to dangers like short-circuit, burns, electric shock, burns due to ultraviolet radiation, lamp explosion, crash etc.

3. Description of the device

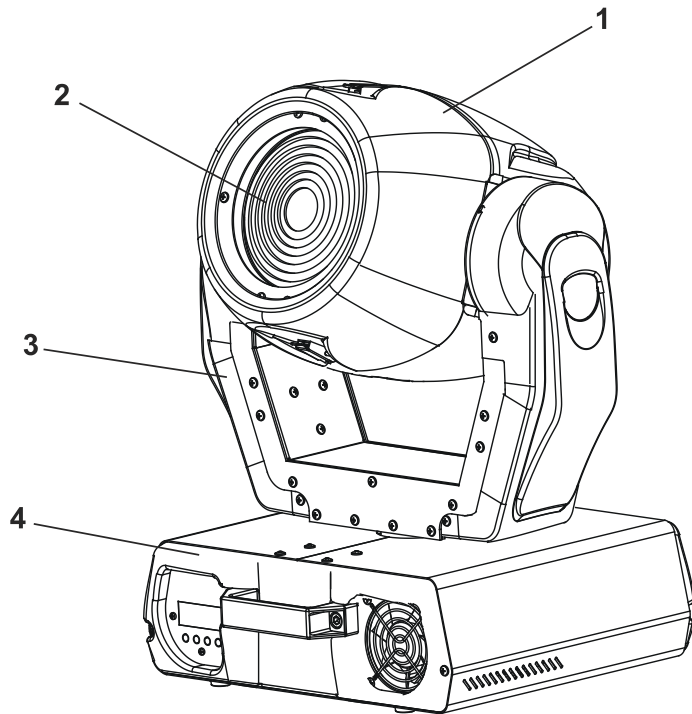

- 1 - Moving head
- 2 - Fresnel lens
- 3 - Yoke
- 4 - Base

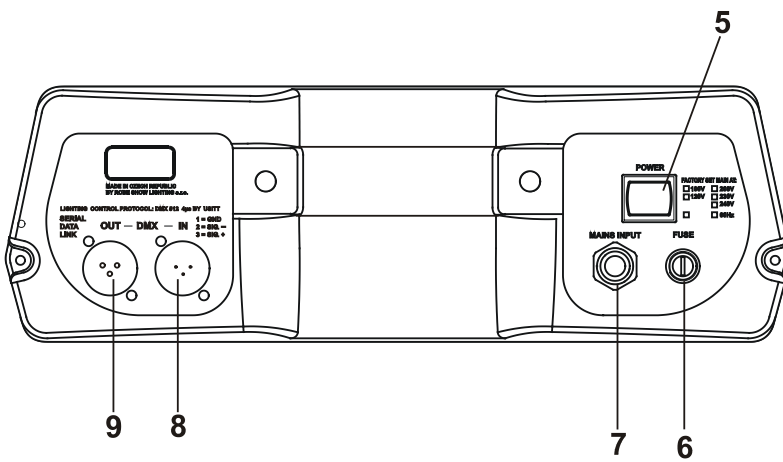

- Rear panel:**
- 5 - Power switch
 - 6 - Fuse holder
 - 7 - Power cord
 - 8 - 3-pin DMX input
 - 9 - 3-pin DMX output

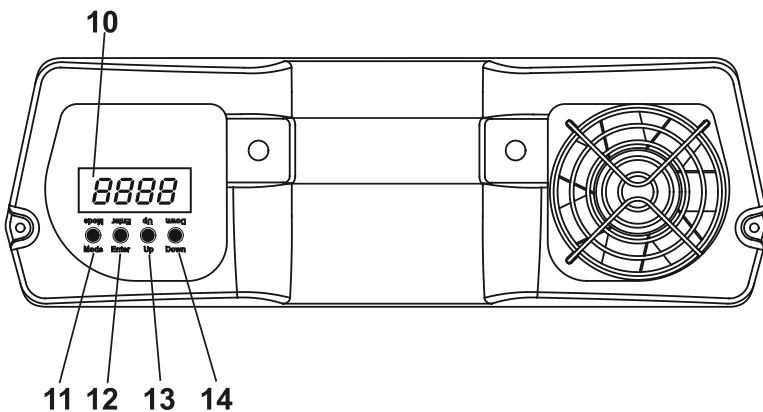

- Front panel:**
- 10 - Display
 - 11 - Mode-button
 - 12 - Enter-button
 - 13 - Up-button
 - 14 - Down-button

4. Installation

4.1 Fitting the lamp

DANGER !
Install the lamps with the device switched off only.
Unplug from mains before !

To insert the lamp, open the lamp cover on the back of the projector head by loosening the 3 fastening screws marked **X,Y,Z** on the cover.

If changing the lamp, remove the old lamp from the socket. Insert the lamp to the socket.

Do not install a lamp with a higher wattage! A lamp like this generates temperatures the device is not designed for.

Damages caused by non-observance are not subject to warranty. Please follow the lamp manufacturer's notes!

Do not touch the glass bulb with bare hands during the installation! Make sure that the lamp is installed tightly into the lampholder system.

Reclose the lamp cover and tighten the 3 quarter-turn fasteners.

Before striking the lamp, reset the "**LAti/rSEt**" and "**LASt/rSEt**" counters in the "**InFO**" menu on the control panel, by pressing the "**Up**" and "**Down**" buttons in one time and then confirming with the "**Enter**"-button.

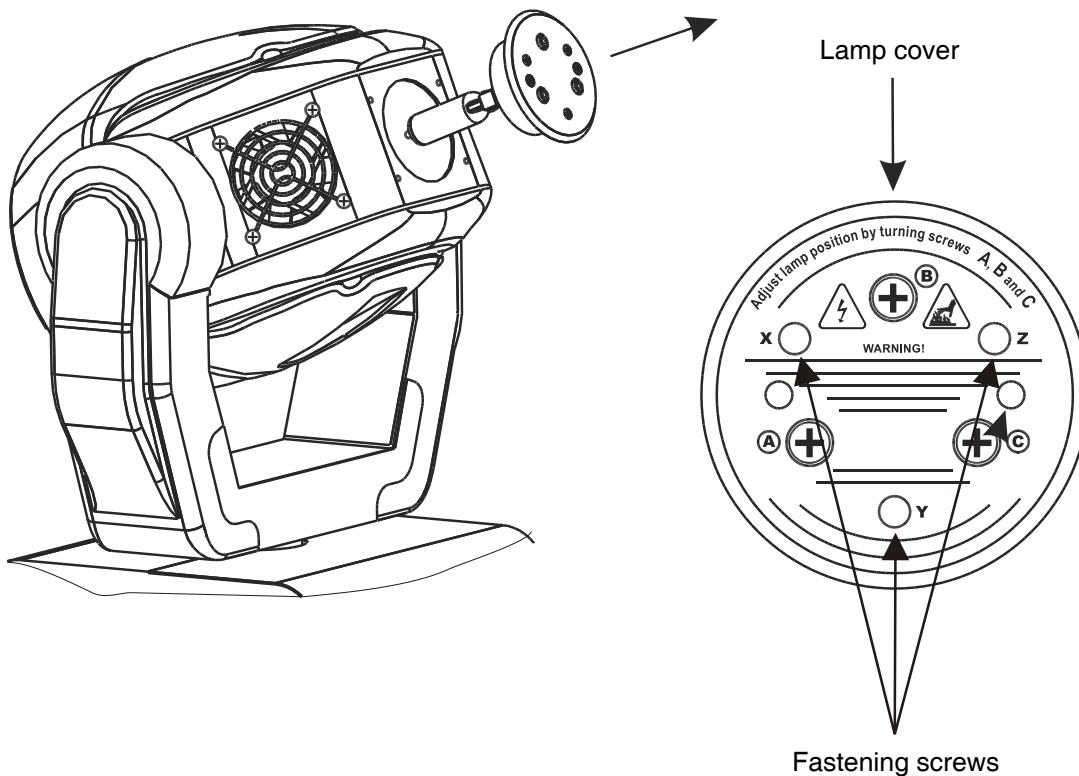

Do not operate this fixture with opened housing-cover!

4.2 Lamp adjustment

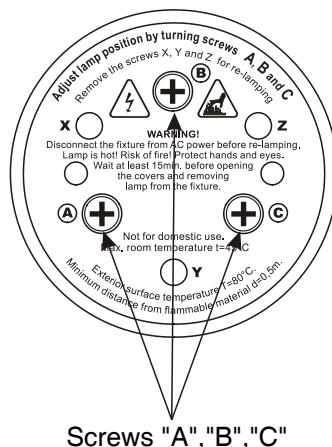

The lampholder is aligned at the factory. Due to differences between lamps, fine adjustment may improve light performance.

Strike the lamp, cancel all effects, open the shutter and set the dimmer intensity onto 100 % and focus the light on a flat surface (wall) or use function “**LAAd**” in the **Special functions**. Center the hot-spot (the brightest part of the beam) using the 3 adjustment screws „**A, B, C**”. Turn one screw at a time to drag the hot-spot, diagonally across the projected image. If you cannot detect a hot -spot, adjust the lamp until the light is even.

To reduce a hot-spot, pull the lamp in by turning all three screws „**A, B, C**” clockwise 1/4-turn at a time until the light is evenly distributed.

If the light is brighter around the edge than it is in the center, or if light output is low, the lamp is too far back in the reflector. „Push” the lamp out by turning the screws „**A, B, C**” counterclockwise 1/4-turn at a time the light is bright and evenly distributed.

4.5 Connection to the mains

Verify the power supply settings before applying power!

If you wish to change the power supply settings, see the chapter below.

Connect the fixture to the mains with the enclosed power plug. If you need to install other power plug on the power cable, follow the identification table below.

The earth has to be connected!

Do not connect the fixture to a dimmer system!

The occupation of the connection-cables is as follows:

Cable (EU)	Cable (US)	Pin	International
Brown	Black	Live	L
Light blue	White	Neutral	N
Yellow/Green	Green	Earth	

4.6 Changing the power supply settings-magnetic ballast

Both the transformer and the ballast must be connected correctly for the local AC voltage and frequency.

The wrong settings can cause poor performance or damage of the moving head. The factory settings are printed next to the power switch.

If you want to change the power supply settings, follow the instructions:

1. Disconnect the fixture from AC power.
2. Remove the 2 top base covers by loosening 16 screws.
3. Move the wire ① on the transformer connection block to the position according to the desired voltage.
4. Move the wires ② and ③ on the ballast connection block to the position according to the desired frequency (voltage).
5. Close the base before applying AC power.

Examples:

EU-version:

Power supply settings: 230V/50Hz

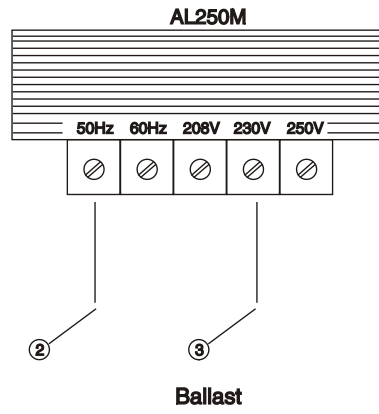
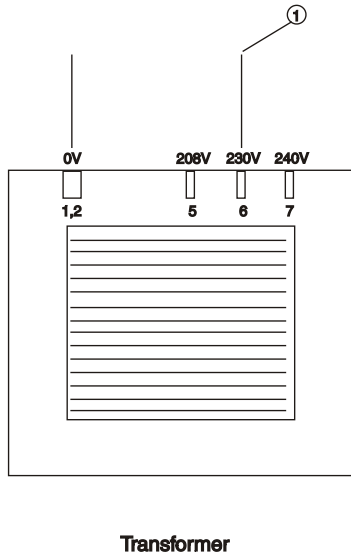

US-version:

Power supply settings: 120V/60Hz

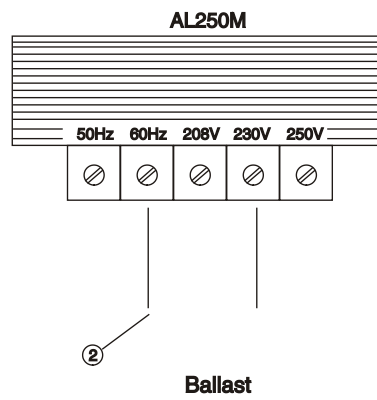
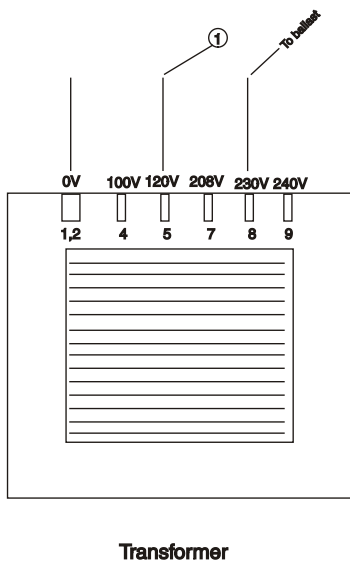

4.7 Manual zoom

The lens system can be configured in the range between 8° and 22° beam angles. To set the desired beam angle, open the front cover of the head by opening the 2 fasteners, loose the 2 adjusting screws on the fresnel lens unit and adjust the required beam angle. Tighten the adjusting screws and place back the front cover of the head.

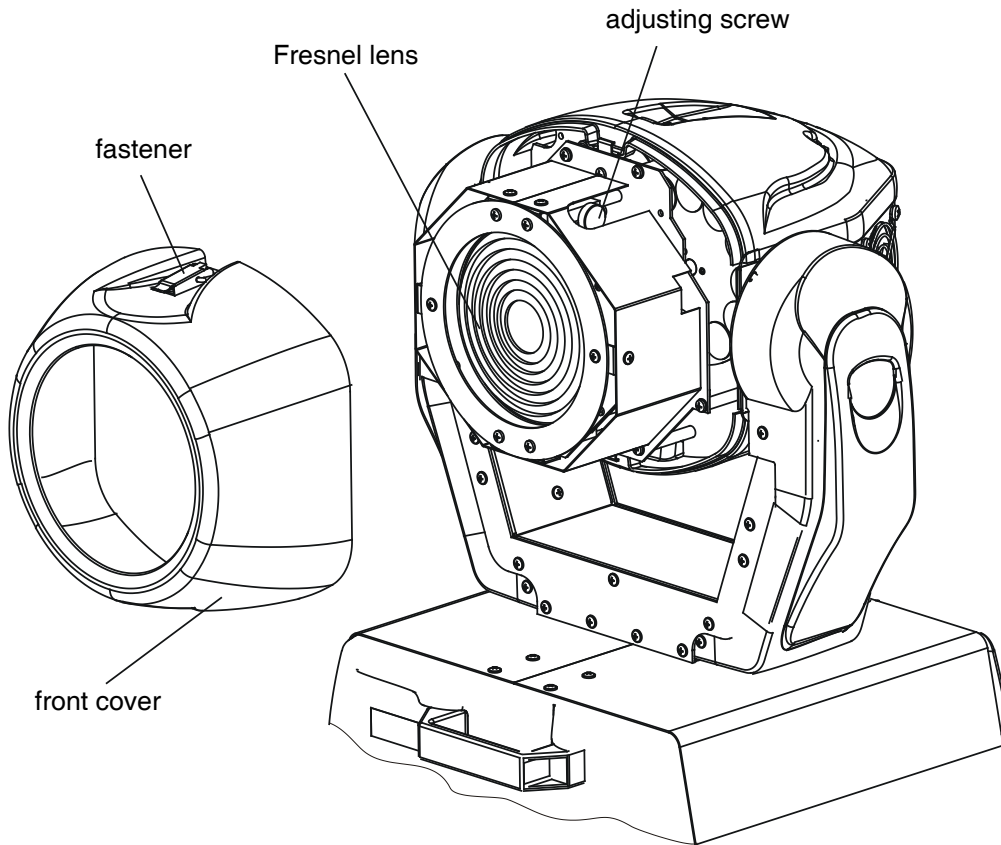

4.7 Rigging the fixture

DANGER TO LIFE!

**Please consider the respective national norms during the installation!
The installation must only be carried out by an authorized dealer!**

The installation of the projector has to be built and constructed in a way that it can hold 10 times the weight for 1 hour without any harming deformation.

The installation must always be secured with a secondary safety attachment, e.g. an appropriate catch net. This secondary safety attachment must be constructed in a way that no part of the installation can fall down if the main attachment fails.

When rigging, derigging or servicing the fixture staying in the area below the installation place, on bridges, under high working places and other endangered areas is forbidden.

The operator has to make sure that safety-relating and machine-technical installations are approved by an expert before taking into operation for the first time and after changes before taking into operation another time.

The operator has to make sure that safety-relating and machine-technical installations are approved by an expert after every four year in the course of an acceptance test.

The operator has to make sure that safety-relating and machine-technical installations are approved by a skilled person once a year.

The projector should be installed outside areas where persons may walk by or be seated.

IMPORTANT! OVERHEAD RIGGING REQUIRES EXTENSIVE EXPERIENCE, including (but not limited to) calculating working load limits, installation material being used, and periodic safety inspection of all installation material and the projector. If you lack these qualifications, do not attempt the installation yourself, but instead use a professional structural rigger. Improper installation can result in bodily injury and/or damage to property.

The projector has to be installed out of the reach of people.

If the projector shall be lowered from the ceiling or high joists, professional trussing systems have to be used. The projector must never be fixed swinging freely in the room.

Caution: Projectors may cause severe injuries when crashing down! If you have doubts concerning the safety of a possible installation, do NOT install the projector!

Before rigging make sure that the installation area can hold a minimum point load of 10 times the projector's weight.

Danger of fire !

When installing the device, make sure there is no highly inflammable material (decoration articles, etc.) in between a distance of min. 0,7 m.

CAUTION!

**Use 2 appropriate clamps to rig the fixture on the truss.
Follow the instructions mentioned at the bottom of the base.
Make sure that the device is fixed properly! Ensure that the structure (truss) to which you are attaching the fixtures is secure.**

The projector can be placed directly on the stage floor or rigged in any orientation on a truss without altering its operation characteristics .

You can fix the fixture on a truss via 2 Omega holders, or using the mounting plate(it is not the standard part of

delivery) or screw the clamps directly to the 2 holes (5) in the base.
 For overhead use, always install a safety-rope that can hold at least 10 times the weight of the fixture. You must only use safety-ropes with screw-on carabines. Pull the safety-rope through the two apertures on the bottom of the base and over the trussing system etc. Insert the end in the carabine and tighten the fixation screw.

Fixation via the omega holders

1. Bolt each clamp (1) to the omega holder (4) with M12 bolt and lock nut through the hole in the holder.
2. Fasten the omega holders on the bottom of the base by inserting both quick-lock fasteners (3) into the holes of the base and tighten fully clockwise.
3. Fasten the safety-rope (2) through the two apertures on the bottom of the base and over the trussing system.

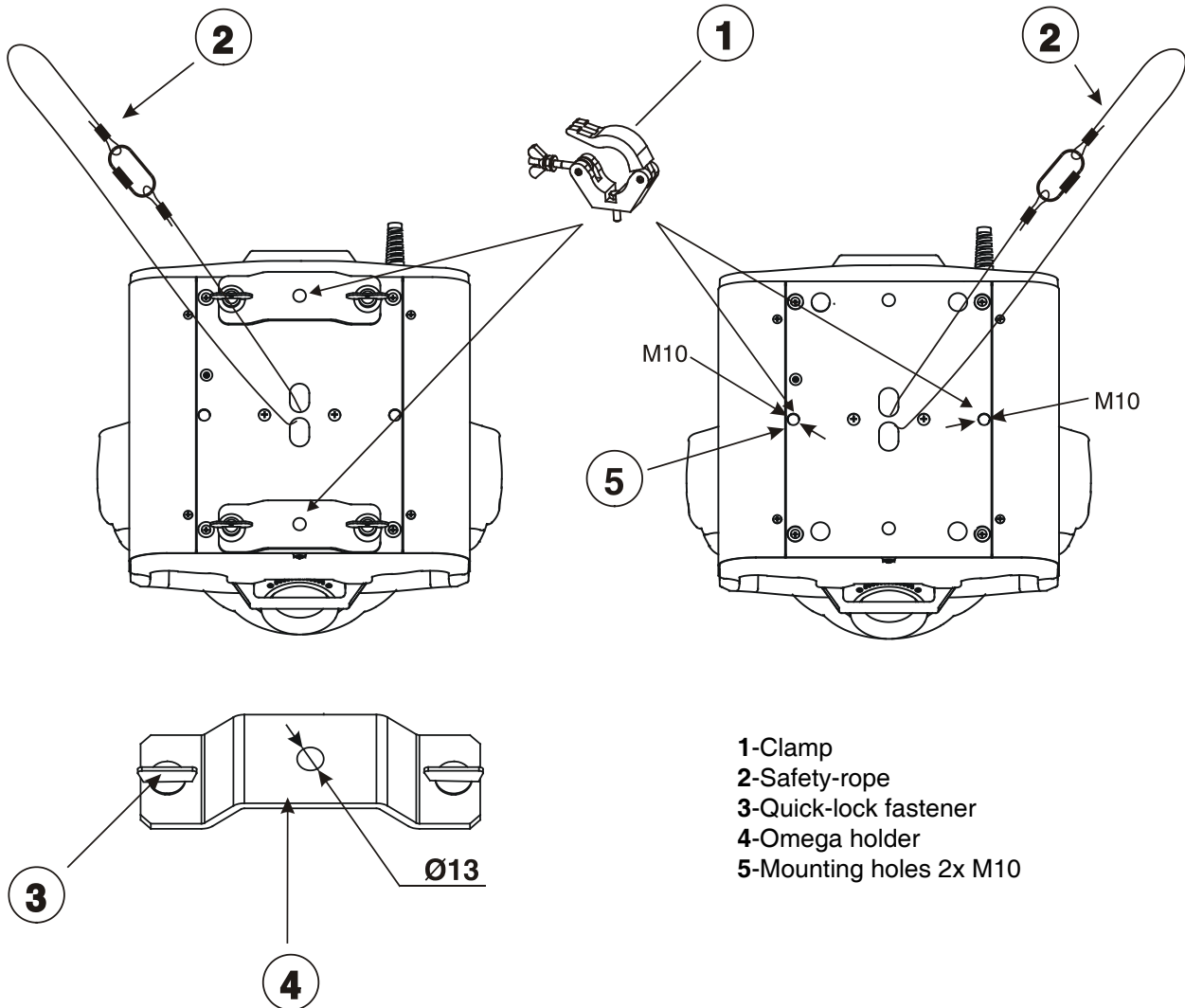

**When installing fixtures side-by-side,
 avoid illuminating one fixture with another!**

**DANGER TO LIFE!
 Before taking into operation for the first time, the installation has
 to be approved by an expert!**

Fixation via a mounting plate

1. Screw 2 clamps (1) to the mounting plate (4) with M12 bolts and lock nuts through the holes in the mounting plate (4).
2. Insert the 4 quick-lock fasteners (3) into the holes on the bottom of the base and tighten fully clockwise.
3. Fasten the safety-rope (2) through the two apertures on the bottom of the base and over the trussing system.

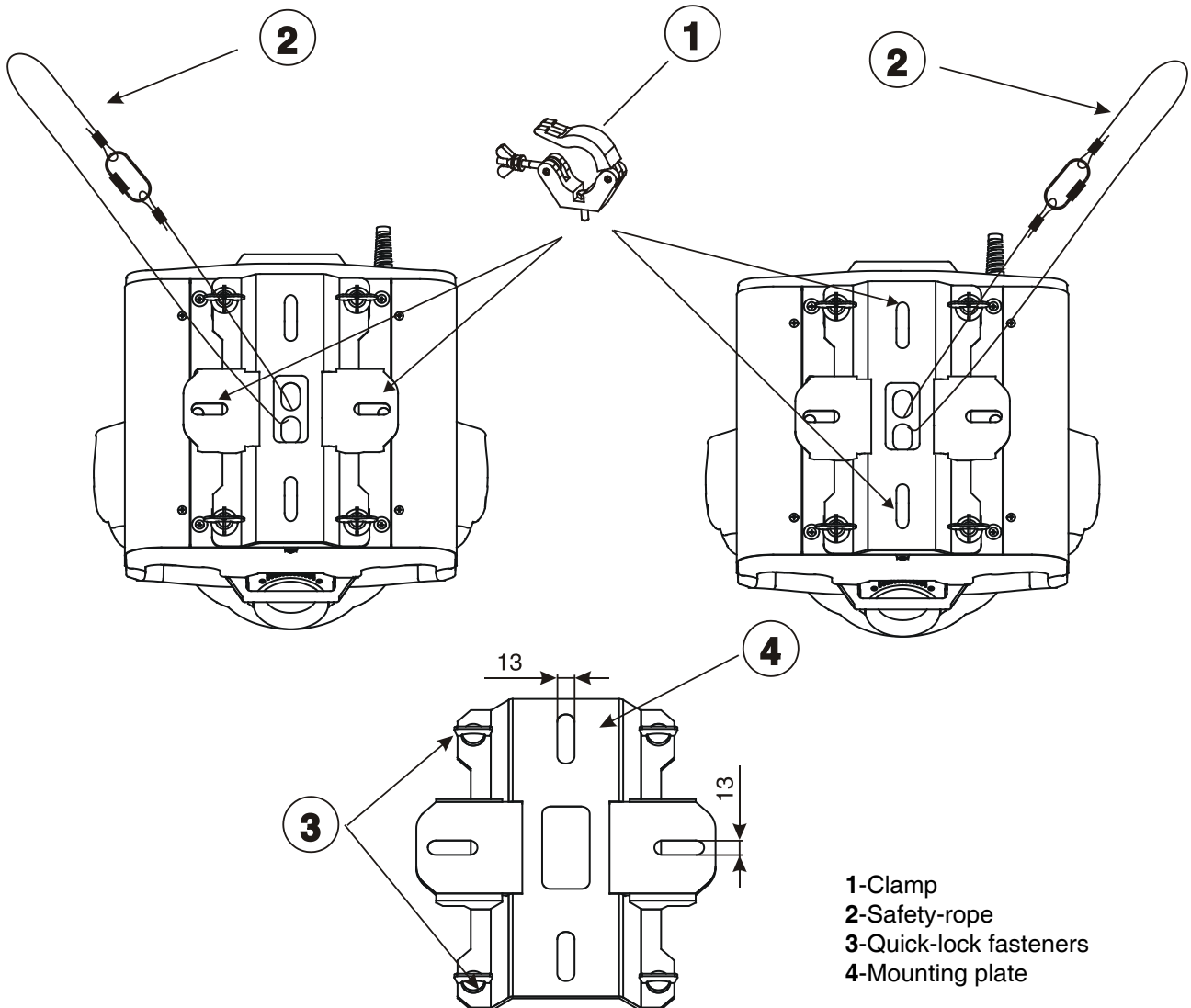

4.8 DMX-512 connection/connection between fixtures

The fixture is equipped with 3-pin XLR sockets for DMX input and output. Only use a shielded twisted-pair cable designed for RS-485 and 3-pin XLR-plugs and connectors in order to connect the controller with the fixture or one fixture with another.

DMX - output

XLR mounting-socket (rear view):

- 1 - Ground
- 2 - Signal (-)
- 3 - Signal (+)



DMX-input

XLR mounting-plug (rear view):

- 1 - Ground
- 2 - Signal (-)
- 3 - Signal (+)

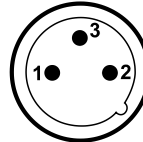

If you are using the standard DMX controllers, you can connect the DMX output of the controller directly with the DMX input of the first fixture in the DMX-chain. If you wish to connect DMX-controllers with other XLR-outputs, you need to use adapter-cables.

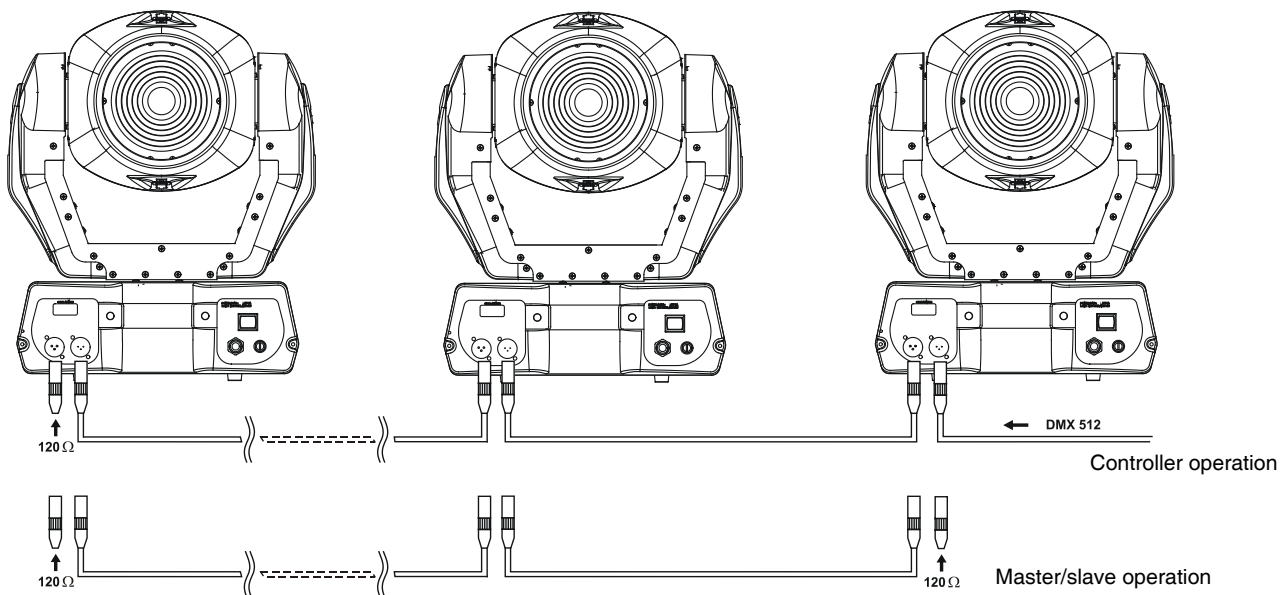

Building a serial DMX-chain:

Connect the DMX-output of the first fixture in the DMX-chain with the DMX-input of the next fixture. Always connect one output with the input of the next fixture until all fixtures are connected.

Caution: At the last fixture, the DMX-cable has to be terminated with a terminator. Solder a 120 Ω resistor between Signal (-) and Signal (+) into a 3-pin XLR-plug and plug it in the DMX-output of the last fixture.

Building a master/slave-chain:

Connect the DMX-output of the master fixture in the data-chain with the DMX-input of the first slave. Always connect output with the input of the next slave until all slaves are connected (up to 9 fixtures).

Caution: It's necessary to insert the XLR termination plug (with 120 Ohm) into the input of the master fixture and into the output of the last slave fixture in the link in order to ensure proper transmission on the data link.

5.ClubWash 300 CT-DMX Protocol-version 1.0

Mode 1 Channel	Mode 2 Channel	8-bit channel	Value	Function	Type of control
1	1	1	0-255	Pan Coarse control of pan movement	proportional
3	2		0-255	Pan Fine Fine control of pan movement	proportional
2	3	2	0-255	Tilt Coarse control of tilt movement	proportional
4	4		0-255	Tilt fine Fine control of tilt movement	proportional
5	5	3	0 1-249 250-255	Speed of Pan/Tilt movement Max. speed (tracking mode) From max.speed to min.speed (vector mode) Max.speed (tracking mode),black-out while colour changing or pan/tilt moving	step proportional step
6	6	4	0-127 128-139 140-229 230-239 240-255	Lamp On/Off,reset,speed control of fans From max.speed of fans to min. speed of fans Lamp On,reset No function Lamp Off after 3 sec. No function	proportional step step step step
7	7	5	0-17 18-35 36-53 54-72 73-90 91-108 109-127 128-190 191-192 193-255	Colours Open/White Red Blue Green CTF 3200 K CTF 5600 K UV filter Forwards rainbow effect from fast to slow No rotation Backwards rainbow effect from slow to fast	step step step step step step step proportional step proportional
8	8	6	0-255	Cyan Cyan (0-white,255-full)	proportional
9	9	7	0-255	Magenta Magenta (0-white,255-full)	proportional
10	10	8	0-255	Yellow Yellow (0-white,255-full)	proportional
11	11	9	0-255	Speed of CMY and dimmer From max.speed to min.speed	proportional
12	12	10	0-7 8-15 16-23 24-31 32-39 40-47 48-55 56-63 64-71 72-79 80-87 88-95 96-103 104-111 112-119	Colours macros-CMY and colour wheel Off Macro 1 Macro 2 Macro 3 Macro 4 Macro 5 Macro 6 Macro 7 Macro 8 Macro 9 Macro 10 Macro 11 Macro 12 Macro 13 Macro 14	step step step step step step step step step step step step step step step

12	12	10	120-127	Macro 15	step
			128-135	Macro 16	step
			136-143	Macro 17	step
			144-151	Macro 18	step
			152-159	Macro 19	step
			160-167	Macro 20	step
			168-175	Macro 21	step
			176-183	Macro 22	step
			184-191	Macro 23	step
			192-199	Macro 24	step
			200-207	Macro 25	step
			208-215	Macro 26	step
			216-223	Macro 27	step
			224-231	Macro 28	step
			232-239	Macro 29	step
			240-247	Macro 30	step
248-255	Macro 31	step			
13	13	11	0-70	Effect wheel Full beam	step
			71-180	Beam shaper	proportional
			181-255	Frost filter	proportional
14	14	12		No function	
15	15	13	0-31	Shutter, Strobe Shutter closed	step
			32-63	Shutter open	step
			64-95	Strobe-effect from slow to fast	proportional
			96-127	Shutter open	step
			128-143	Closing pulses from slow to fast	proportional
			144-159	Opening pulses from fast to slow	proportional
			160-191	No function	step
			192-223	Random strobe -effect from slow to fast	proportional
224-255	Shutter open	step			
16	16	14	0-255	Dimmer intensity Dimmer from closed to 100% light output	proportional

6. Controller mode

The fixtures are individually addressed on a data link and connected to the controller. The fixtures respond to the DMX signal from the controller.

6.1 DMX addressing

The control panel on the front panel of the fixture allows you to assign the DMX fixture address, which is defined as the first channel from which the ClubWash 300 will respond to the controller.

If you set, for example, the address to channel 11, the ClubWash 300 will use the channel 11 to 20 for control (if 16-bit resolution is selected).

Please, be sure that you don't have any overlapping channels in order to control each ClubWash 300 correctly and independently from any other fixture on the DMX data link.

If two, three or more ClubWash 300 are addressed similarly, they will work similarly.

For address setting, please refer to the instructions under "Addressing"(menu "A001").

Controlling:

After having addressed all ClubWash 300, you may now start operating these via your lighting controller.

Note:After switching on, the ClubWash 300 will automatically detect whether DMX 512 data is received or not. If there is no data received at the DMX-input, the display will start to flash "A001" with actually set address.

This situation can occur if:

- the 3 pin XLR plug (cable with DMX signal from controller) is not connected with the input of the ClubWash 300
- the controller is switched off or defective, the cable or connector is defective or the signal wires are swap in the input connector.

Note:It's necessary to insert the XLR termination plug (with 120 Ohm) to the last fixture in the link in order to ensure proper transmission on the DMX data link.

6.2 Remotely controllable functions

Lamp

A relay inside of the ClubWash 300 allows you to switch on and off the lamp via the control panel or via your DMX-controller without affecting the rest of the lighting.

To switch On/Off the lamp, please refer to "Lamp On/Off" (menu **LAMP**).

Note:It is also important to note, that the discharge lamp is cold restrike types, that means, that they have to be cold before re-striking. For this reason, you have to wait 5 minutes (max. speed of fan must be adjusted) after having switched Off the lamp before you can switch it back On again. If you try to switch On the lamp within 5 minutes after having switched it Off, the ClubWash 300 will store this information and automatically ignite the lamp when the 5 minutes period has expired. The message "HEAT" will appear on the control panel display of the ClubWash 300. If the ignition of the lamp is seven times unsuccessful, on the display will appear "LA.Er", meaning that the lamp could be damaged or even missed, or there could be a failure on the ignitor or ballast.

Colour wheel

This wheel contains 6 dichroic filters and an open position.

Dimmer/Shutter/Strobe

Smooth 0 - 100 % dimming is provided by the combined mechanical dimmer/shutter unit. This unit may also be used for strobe effect.

Fans

The ClubWash 300 is cooled by 3 axial fans - 2 in the projector head and one in the base. By the control board using the "FAnS" function you can choose the 4 types of the fan speed operating modes.

7. Stand - alone mode

The fixtures on a data link are not connected to the controller but can execute pre-set programs which can be different for every fixture. To set the program to be played, see the "Stand-alone setting" (menu "St.AL.").

"Stand-alone operation" can be applied to the single fixture (the fixture may be set to the master /slave mode or controller mode) or to multiple fixtures operating synchronously.

Synchronous operation of multiple fixtures requires that they must be connected on a data link and one of them is set as a master (master mode) and the rest as the slaves (slave mode). The slaves are assigned to SLA1-SLA9 and on the certain slave address can be connected only one fixture. To set the fixture as the master or slave , see the "Addressing" (menu "A001").

If the master fixture runs a reset, switches On/Off the lamp or plays test(program) ,all slaves will execute these acts too (e.g. if the master fixture has switched the lamp off, no slaves can switch the lamp on)!

The master fixture starts simultaneous program start in the other slave fixtures. All fixtures have a definite, synchronized starting point when playing back their programs. The number of running program is the same in all slaves and depends on the master's choice (menu "St.AL."). Every fixture runs its program repeatedly , starting the program step No.1 when requested by the master .

For example:

If the slave fixture has a shorter program length, it will continuously repeat its program until the master fixture finishes its own program and restarts its program running (slave 1- prog.step 3 will not be finished).

If the slave fixture has a longer program length, it will restart at prog. step 1 before it completes all its prog.steps

(slave 2 - prog.step 5 will not be played)- see the picture bellow.

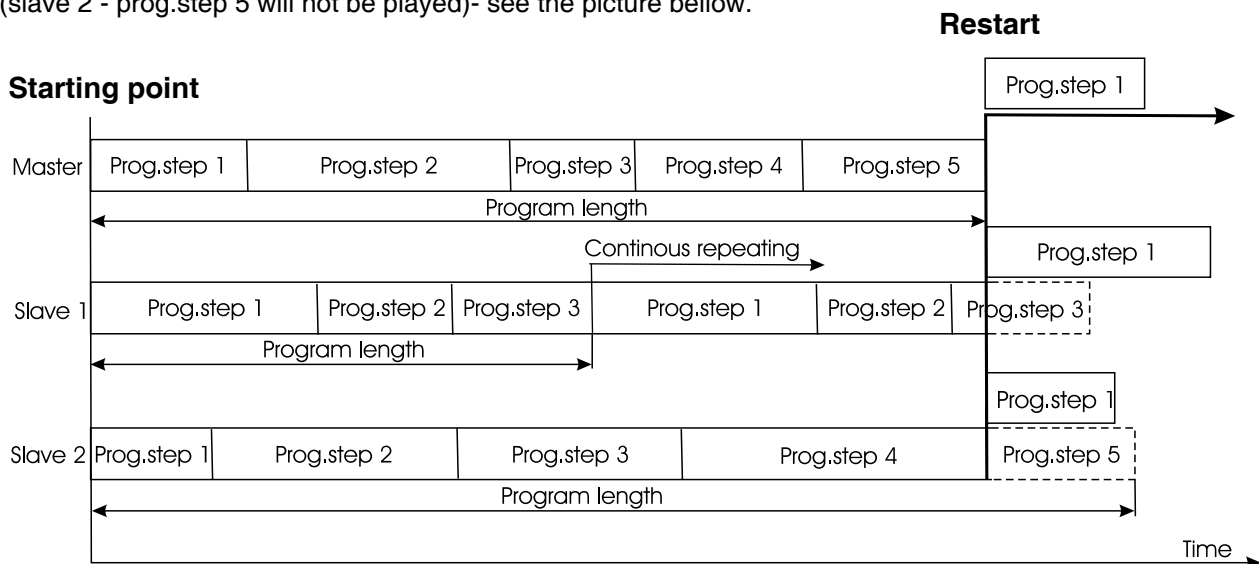

Note: Disconnect the fixtures from the DMX controller before master/slave operating , otherwise data collisions can occur and the fixtures will not work properly!

8.Control menu map

Default settings=**Bold print**

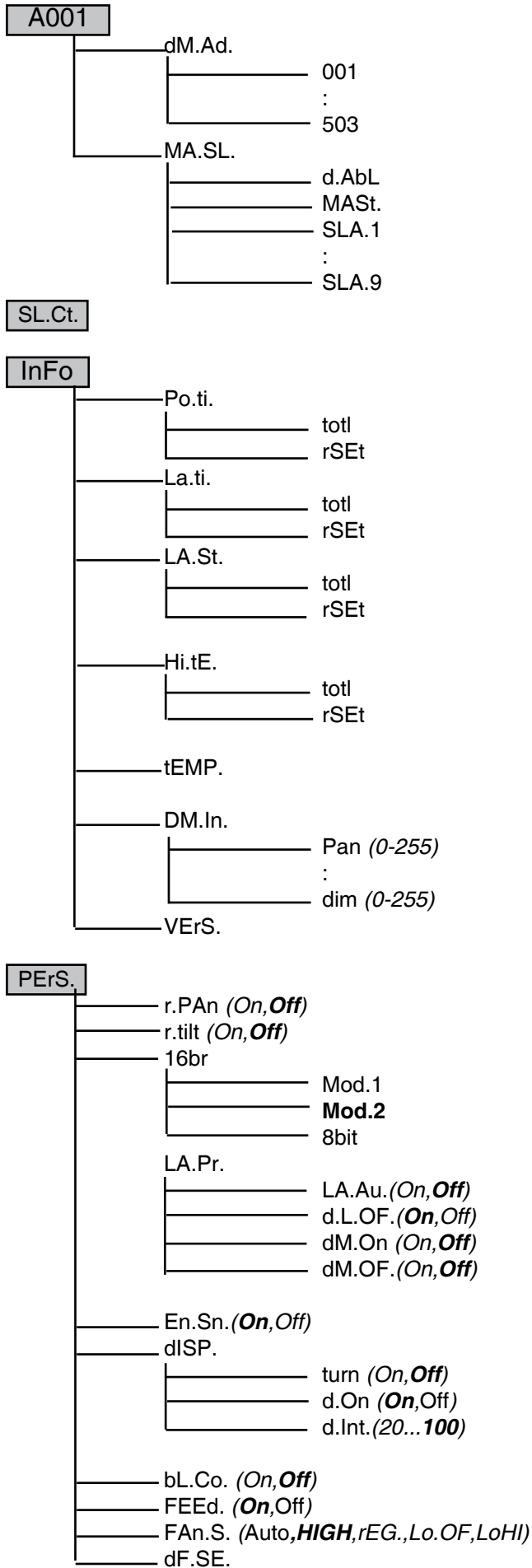

LAMP (On, Off)

tEst

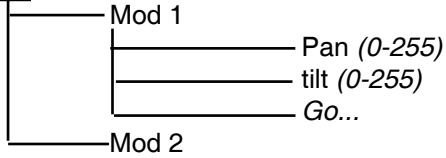

St.AL.

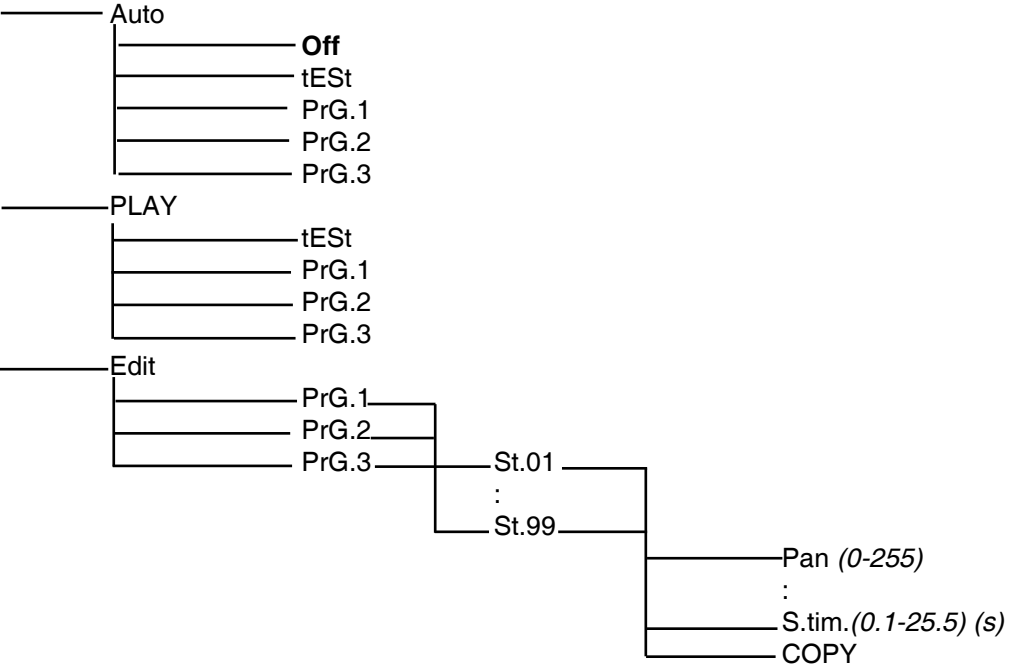

rESE.

SPEC.

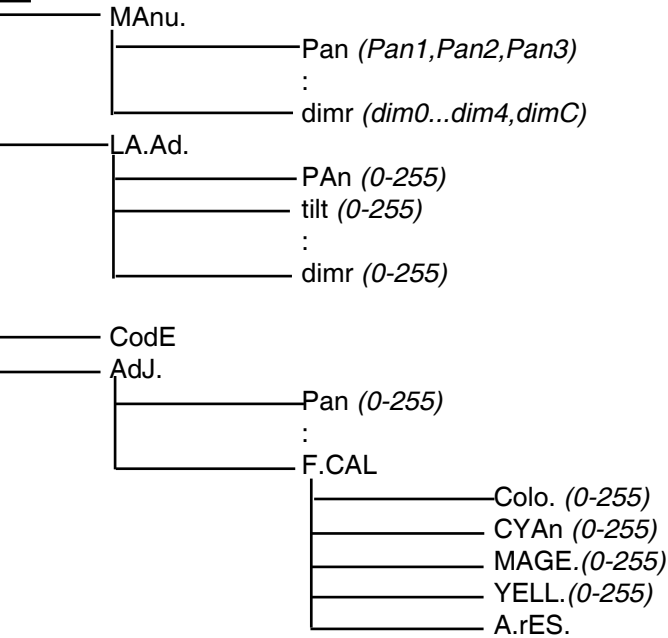

9. Control menu

The control panel situated on the front panel of the base offers several features. You can simply set the DMX address, read the number of the lamp or unit hours, switch On and Off the lamp, run test, make a reset and also use many functions for setting fixture behaviour.

Control elements on the control board:

[MODE] button-leaves menu without saving changes.

[ENTER] button- enters menu, confirms adjusted values and leaves menu.

[UP] button and [DOWN] button- moves between menu items on the the same level, sets values.

After switching the fixture on, the display shows the initial screen:



Use [UP],[DOWN] to browse through the menu. To select a function or submenu, press [ENTER].

9.1 Fixture Address



Use this menu to set the DMX address of the fixture or set the fixture as a Master (Slave).

dM.Ad. --- **DMX addressing.** Select this submenu to set DMX start address.

MA.SL. --- **Master/slave addressing.** Select this submenu to set the fixture as a Master or Slave (Slave1-Slave 9). Option "d.AbL" deactivates master/slave setting.

9.2 Slave control



This function allows you to control the slaves from the master's control panel in a master/slave operation. Select this function from the main menu and press [ENTER]. Browse the list of all connected slaves ("SL.C.1" - "SL.C.9") by pressing [UP] or [DOWN]. Select the desired slave and press [ENTER]-button. The matching slave control panel is available from the master control panel.

Note: This function is available from the master fixture only.

9.3 Fixture informations



Use this menu to read an useful information about the fixture.

Po.ti. --- **Power on time.** Select this submenu to read the number of operation hours.

totL --- The function shows the total number of the operation hours since the ClubWash 300 has been fabricated.

rSEt --- The function shows the number of the operation hours that the ClubWash 300 has been powered on since the counter was last reset. In order to reset this counter to 0 you have to hold [UP] and [DOWN] and press the [ENTER].

La.ti. --- **Lamp on time.** Select this submenu to read the number of the operation hours with the lamp on.

totL --- The function shows the total number of the operation hours with the lamp on since

the ClubWash 300 has been fabricated.

rSEt --- The function shows the number of the operation hours with the lamp on that the ClubWash 300 has been powered on since the counter was last reset. In order to reset this counter to 0 you have to hold [UP] and [DOWN] and press the [ENTER].

LA.St. --- **Lamp strikes.** Select this submenu to read the total number of the lamp strikes.

totL --- The function shows the total number of the lamp strikes since the ClubWash 300 has been fabricated.

rSEt --- The function shows the number of the lamp strikes since the counter was last reset. In order to reset this counter to 0 you have to hold [UP] and [DOWN] and press [ENTER].

Hi.tE --- **Max.fixture head temperature.** Select this submenu to read the max. fixture head temperatures (°C).

totL - The function shows the max. temperature of the head inside since the ClubWash 300 has been fabricated.

rSEt - The function shows the maximum temperature of the head inside since the counter was last reset. In order to reset the counter to 0 you have to hold [UP] and [DOWN] and press the [ENTER].

tEMP --- **Current head temperature.** Select this submenu to read the current fixture head temperature (°C). Temperatures below 95°C are not critical. 95° C and more lead to the lamp being switched off. Please note that the outside temperature should not exceed 45° C.

DM.In. --- **Readout of DMX values.** Select this function to read DMX values (0-255) of each channel received by the fixture.

- | | | | |
|---------------|------------------------|--------------|-------------------|
| PAn | a coarse pan movement | CYAn | a cyan colour |
| F.PAn | a fine pan movement | MAGE. | a magenta colour |
| tilt | a coarse tilt movement | YELL. | a yellow colour |
| F.tilt | a fine tilt movement | C.SpD | a colour speed |
| SpEd | a pan/tilt speed | MACr. | a CMY macro |
| Func. | a special function | EFFE. | a effect wheel |
| Colo | a colour wheel | Stro. | a shutter, strobe |
| | | dimr | a dimmer |

VErS. --- **Software version.** Select this function to read the software version of the display module.

9.4 Personality



Use this menu to modify ClubWash 300 operating behavior.

r.PAn --- **Pan reverse.** Select this function to invert the pan movement.

r.tilt --- **Tilt reverse.** Select this function to invert the tilt movement.

LA.Pr. --- **Lamp presetting.** Select this menu to change the lamp "behaviour".

LA.Au. --- Select this function to turn the lamp on automatically after switching the fixture on.

d.L.OF. --- Select this function to switch off the lamp via DMX.

dM.On --- This function allows you to strike the lamp automatically after 26 seconds if DMX signal is present on the data link. If the ignition is unsuccessful (e.g. lamp is too hot), the fixture will try to ignite the lamp after next 26 s. This process will repeat until the lamp lights.

dM.OF. --- This function allows you to switch Off the lamp automatically after 2 minutes if DMX signal is missing on the data link.

16b.r. --- **16bit resolution.** By this function you can adjust the 16-bit movement resolution (Mod1, Mod 2) or 8-bit resolution (8bit).

En.Sn. --- Switching on/of the lamp light sensor.Select this function to switch the lamp light sensor on or off.The option"On" is for the standard operation.

Important: The option"Off" is for "emergency operation" only if the lamp light sensor is defective and you will wait for a service intervention! If the lamp light sensor is switched off and at switching the lamp on the electronics will still try to ignite the lamp until it shines (even when the lamp is damaged or absent), on this account some electronics parts could be damaged!

DiSP. --- Display adjusting.This function allows you to change the display settings.

turn --- Select this function to turn the display by 180°.

d.On --- This function allows you to keep the display on or to turn off automatically 2 minutes after last pressing any button on the control panel.

d.Int. --- Select this function to adjust the display intensity (20-min.,100-max.).

bL.Co. --- Blackout during movement correction.Select this function to enable the blackout during the head movement correction (if the moving head lost its right pan/tilt position for a short moment).

FEEd --- Pan/Tilt feedback.This function allows to return the moving head to the required pan/tilt position after changing the position by external force (e.g.by stroke).

Be careful, the Pan/Tilt Feedback OFF is not the standard operation and the head of the fixture can be damaged!

Note: If the feedback was switched off ,the pan/tilt-position is changed by an external force and the feedback is switched on again,the moving head might not to be synchronized with the DMX signal.You have to make a reset in order to synchronize the moving head with the DMX signal.

Fan.S. --- Fan speed operating modes.By using this function you can choose 3 types of the fans speed operating modes.

Auto --- The fans automatically raise their speed in order to control inside temperature of the head.

HIGH --- The cooling fans work on max. speed (max. cooling).

reg --- This mode is similar to "Auto" but the initial level of the fans speed can be adjusted by DMX values on the channel 6 (see DMX protocol).

Lo.OF. --- The fans keep the adjusted low speed until the temperature exceeds max. inside temperature of the fixture, then the ClubSpot 300 automatically switches off the lamp.

Lo.HI. --- The fans keep the adjusted low speed until the temperature exceeds max. inside temperature of the fixture, then the ClubSpot 300 automatically switches from low to high the fan speed.

dF.SE. --- Default Settings .Select this option to reset all fixture personalities to the default values.

9.5 Lamp On/Off



Use this option in order to switch on/off the lamp.It is also important to note, that the lamp is cold restrike type, that means, that it has to be cold before striking.

9.6 Test sequences



Use this menu to to run a special demo-test sequences without an external controller, which will show you some possibilities of using ClubWash 300.

Mod. 1 --- Mode 1. This mode is suitable for projections on the wall, ceiling or ground without any head movement.

Mod. 2 --- Mode 2.This mode uses all ClubWash 300 functions including pan/tilt movement and therefore is good for a complete introduction of the fixture.

9.7 Stand-alone setting



Use this menu to set options for stand-alone mode as a selection of the playing program, programming and modifying current programs.

Auto --- Presetting playback. This function allows you to select the program which will be played in the stand-alone mode after switching the fixture on. Selected program will be played continuously in a loop.

d.Abl --- The option disables "Auto" function.

tESt --- The option will start built-in test program.

PrG. 1 --- The option will start created program No.1

PrG. 2 --- The option will start created program No. 2

PrG. 3 --- The option will start created program No. 3

Note: If the fixture operates in the controller mode (DMX controller is connected) and any program from this menu is selected , in this case the fixture will not respond to the DMX controller after switching on and will play selected program.

PLAY --- Playing program. Select this menu to run a built-in program or the 3 freely-programmable programs in a loop.

tESt --- The option starts built-in test program.

PrG.1 --- The option starts created program No. 1

PrG.2 --- The option starts created program No. 2

PrG. 3 --- The option starts created program No. 3

Select the program you wish and press [ENTER]. The selected program starts running. By Pressing [ENTER] again is possible to pause the program running.

Edit --- Editing program. Select this menu to edit or create the program. The ClubWash 300 has one built-in program and the 3 free programs, each up to 99 steps. Each program step has a step time. Step time - the time, during which effects last in the current step.

If the fixture is set as a master, then you may edit any program in the slaves. You can't edit programs on the slave fixtures from their control panels if the master fixture is switched on and connected to the slaves (editing is possible by the master control panel only).

Procedure:

1. Press [UP] or [DOWN] to select the program you want to edit ("PrG.1" - "PrG.3") and press [ENTER].
2. Press [UP] or [DOWN] to select the desired fixture ("MASt." - "SLA.9") and press [ENTER]-button.
3. Press [UP] or [DOWN] to select the desired program step ("St.01" - "St.99") and press [ENTER]-button.
4. Press [UP] or [DOWN] to select the desired item and press [ENTER]-button. Now you can edit by [UP] or [DOWN] buttons the DMX value (0-255) for selected item:

P.End. - a total number of the program steps (value 1-99). **This value you must set before start programming** (e.g. if you want to create program with the 10 steps, set P.End=10).

PAn a coarse pan movement

tilt a coarse tilt movement

SpEd a pan/tilt speed

Func. a special function

Colo a colour wheel

CYAn a cyan colour

MAGE. a magenta colour

YELL. a yellow colour

C.Spd a colour speed

MACr. a CMY macro

EFFE. a effect wheel

Stro. a shutter, strobe

dimr a dimmer

S.tim. a step time, value 0,1-25,5 seconds

COPY. - copying the current prog. step to the next prog. step. If the last prog. step is copied to the next prog. step, parameter "P.End" is increased about one by itself (except step 99).

5. Press [ENTER]-button to confirm adjusted value.

6. Press [MODE]-button, select next prog. step and repeat this procedure (steps 4 - 6).

9.8 Reset function



This option enables the ClubWash 300 to index all effects (functions) and return to their standard positions.

9.9 Special functions



Use this menu for special services like adjusting lamp or adjusting effects.

MAnu. --- **Manual control of the effects.** Select this menu to call up presetted positions of the channel effects.

LA.Ad. --- **Lamp adjustment.** This function can be used when you make the fine adjustment of the lamp. If you select this function, all effects will be canceled, shutter will be opened and the dimmer intensity will be set onto 100%. By using the options "**PAn, tilt, CYAn, MAGE, YELL, dimr**" you can focus the light on a flat surface (wall) and perform the fine lamp adjustment.

Code --- **Code.** This function contains identification hexadecimal code (0000-FFFF) for the fixture, which is used for the master/slave operation.

AdJ. --- **Effect adjustment.** By this function you can calibrate and adjust the effects to their standard/right positions. Disconnect the DMX controller from the fixture and select "**AdJ.**" menu. The display shows step by step effects by which you can adjust the fixture to the required position before the function calibration (DMX controller must be disconnected). When the positioning is finished, select "**F.CAL.**" and press [ENTER]:

1. Calibration via the control board

Disconnect DMX controller from the fixture. Press [ENTER] and use [UP] and [DOWN] in order to display the following item: "**Colo., CYAn, MAGE, YELL**" for very smooth function calibration. Press [ENTER] and use the [UP] and [DOWN] in order to adjust its right value from 0 to 255. Then press [ENTER] to confirm or [MODE] to cancel and return to the menu. When the calibration is finished, it is necessary to use the "**A.rES**" function in order to write the calibration value to the memory (EPROM) and to make a reset in order to check the newly adjusted positions of the colour wheel. When the reset of the fixture is finished, the display will show the "**F.CAL**" message. Press [ENTER] to repeat the calibration or [MODE] to return to the "**AdJ.**" menu.

2. Calibration via the external controller

Connect the DMX controller to the fixture, press [ENTER] and the [UP] and [DOWN] buttons in order to display the following item: "**Colo., CYAn, MAGE, YELL**". Select one of them and press [ENTER].

Now you can calibrate this effect by your controller. The DMX calibration protocol is described in the table mentioned below.

DMX calibration protocol:

Effect	pan/tilt resolution=16bit (Mode1,Mode2)
Colour wheel (<i>smooth microstep movement</i>)	channel 1
Cyan (<i>smooth microstep movement</i>)	channel 2
Magenta (<i>smooth microstep movement</i>)	channel 3
Yellow (<i>smooth microstep movement</i>)	channel 4
No function	channel 5
No function	channel 6
Standard DMX protocol:	
Colour wheel	channel 7
:	:
Dimmer	channel 16

After having calibrated required effects, press [ENTER] to confirm (or [MODE] to cancel and return to the menu without reset by the "**A.rES.**" function) and use the "**A.rES.**" function in order to write the calibration value to the memory (EEPROM) and to make a reset in order to check the new adjusted positions of the colours.

10. Error and information messages

HEAt

This message appears if you try to switch on the lamp within 5 minutes after having switched it off (the lamp is too hot). The message will appear on the display if the lamp doesn't ignite within 28 seconds. The ClubWash 300 will store this information and automatically ignite the lamp when the 5 minutes period has expired.

Caution: The message is disabled if the lamp light sensor (function "En.Sn.") is switched Off (only if the lamp was turned Off and On within 5 minutes, the message "HEAt" will appear).

LA.Er.

The ignition of the lamp is seven times unsuccessful (the "HEAt" message appeared six times before), and the display shows "LA.Er", meaning that the lamp could be damaged or even missed, the fixture is overheating (this can occur if the ambient temperature is 40° C or more) or there could be a failure on the ignitor or ballast.

Please place or replace the lamp, check the ambient temperature or contact your dealer if the situation was not caused by the lamp.

Caution: The message is disabled if the lamp light sensor (function "En.Sn.") is switched Off.

Mb.Er.

This message informs you that the main PCB does not communicate correctly with the Control Board.

Co.Er. (color wheel error)

This message will appear after the reset of the fixture if the magnetic-indexing circuit malfunctions (sensor failed or magnet missing) or the stepping-motor is defective (or its driver circuit on the main PCB). The color-wheel is not located in the default position after the reset.

set.

Ft.Er.

This error message informs you that the fixture was overheating (occured if the ambient temperature is 40° C or more) and that the relay switched off the lamp.

Fr.Er.

This message will appear if the frequency of the main is not standard 50 or 60 Hz. This message can appear as a result of the interference during the lamp starting (if the lamp or igniter is old) or as a result of the interference by neighbouring devices. **In these cases the message does not affect the fixture operating!**

Sn.Er.

This message appears if the lamp light sensor is failed.

PoEr

This message will appear if the fixture was shortly disconnect from the main.

PA.Er. (Pan-yoke movement error)

This message will appear after the reset of the fixture if the yoke's magnetic-indexing circuits malfunction (sensors failed or magnet missing) or the stepping motor is defective. (Or its driving IC on the main PCB). The yoke is not located in the default position after the reset.

ti.Er. (TILT-head movement error)

This message will appear after the reset of the fixture if the head's magnetic-indexing circuit malfunctions (sensor failed or magnet missing) or the stepping motor is defective. (Or its driving IC on the main PCB). The head is not located in the default position after the reset.

MA.Er.(Master error)

The message informs you that the fixture was addressed as a master and DMX signal is connected to its input. Disconnect the DMX controller from fixture's input and address the fixture as the master again.

11. Technical specifications

Power supply:

EU-model: Voltage:.....208/230/240V AC, 50/60Hz ~
Fuse:.....T 3.15 A@230V

US-model: Voltage:.....100/120/208/230/240V AC, 50/60Hz ~
Fuse:.....T 6.3 A@120V

Power consumption:.....500 VA

Approved lamps:

Osram HSD 250/80, Philips MSD 250/2, Sylvania BA 250/2 SE

Optical System:

High luminous-efficiency parabolic reflector
-Fresnel lens of diameter 150 mm
-Manually adjustable beam angle from 8° to 22°

Colours:

-CMY - colours mixing system
-6 dichroic-filters plus white
-Red, green, blue colors and 3200K, 5600K, UV filters
-Colour-wheel continuous rotation in both directions (rainbow effect)

Beam effects:

-Beam shaper
-Wide and flat beam can steplesly be rotated by 90°
-Frost filter for softer beam

Strobe:

- Strobe effect with variable speed (max.10 flashes per second)

Dimmer:

- Smooth dimmer from 0 - 100 %

Zoom:

- Manual zoom 8°-22°

Motors:

- 9 high quality stepping-motors controlled by microprocessors

Electronics:

-Addressing, special functions setting, effects calibration via control panel with 4-digit LED display
-Readout fixture and lamp usage, receiving DMX values, temperature, etc
-Built-in analyzer for easy fault finding, error messages
-Remotely switching of the lamp
-Built-in demo sequences
-Black-out while head moving or color changing
-Self-resetable thermo-fuse
-Master/slave operation
-Digital serial input DMX-512
-14 or 16 DMX control channels

Pan/Tilt

-Pan movement range 530°
-Tilt movement range 280°

- 8/16 bit movement resolution
- Automatic Pan/Tilt position correction
- Remotely controllable speed of pan/tilt movement for easy programming
- Movement control:tracking and vector

Rigging

- Stands directly on the floor
- Mounts horizontally or vertically with 2 Omega brackets
- 2 truss orientation
- Safety chain/cord attachment point

Temperatures

- Maximum ambient temperature : 45° C
- Maximum housing temperature : 80° C

Minimum distances

- Min.distance from flammable surfaces: 0.5m
- Min.distance to lighted object: 1.3m

Weight (net):

- EU version:20.3 kg
- US version:23.7 kg

Dimensions(mm)

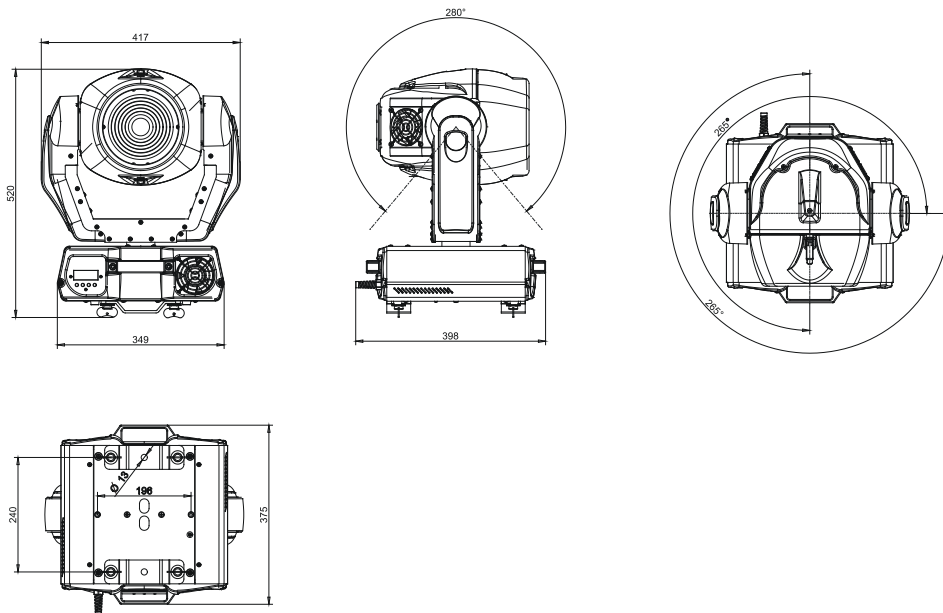

Accessories

Omega holder (2 pieces).....99010420

Optional accessories:

Mounting plate.....99010292

Beampath:

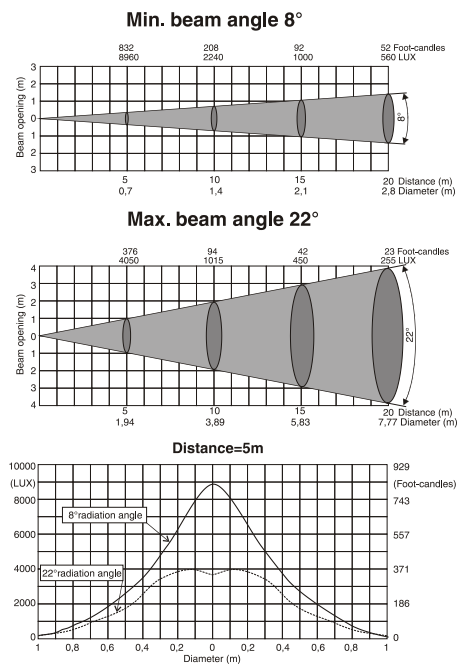

12. Maintenance and cleaning

It is absolutely essential that the fixture is kept clean and that dust, dirt and smoke-fluid residues must not build up on or within the fixture. Otherwise, the fixture's light-output will be significantly reduced. Regular cleaning will not only ensure the maximum light-output, but will also allow the fixture to function reliably throughout its life. A soft lint-free cloth moistened with any good glass cleaning fluid is recommended, under no circumstances should alcohol or solvents be used!

DANGER !
Disconnect from the mains before starting any maintenance work

The front Fresnel lens will require weekly cleaning as smoke-fluid tends to building up residues, reducing the light-output very quickly. The cooling-fans should be cleaned monthly.

The interior of the fixture should be cleaned at least annually using a vacuum-cleaner or an air-jet. The dichroic colour-filters should be cleaned monthly.

There are no serviceable parts inside the device except for the lamp and the fuse. Please refer to the instructions under "Fitting/Exchanging the lamp". Maintenance and service operations are only to be carried out by authorized dealers.

Replacing the fuse

If the lamp burns out, the fine-wire fuse of the device might fuse, too. Only replace the fuse by a fuse of same type and rating.

Before replacing the fuse, unplug mains lead.

Procedure:

- 1) Unscrew the fuseholder on the rear panel of the base with a fitting screwdriver from the housing (anti- clockwise).
- 2) Remove the old fuse from the fuseholder.
- 3) Install the new fuse in the fuseholder.
- 4) Replace the fuseholder in the housing and fix it.

Specifications are subject to change without notice.

