

**ROBE**

# RED Wash 2•36

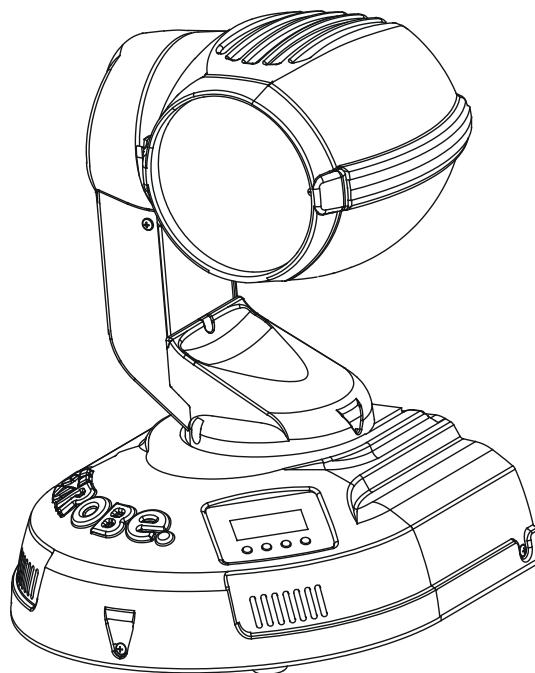

**USER MANUAL**

Version 1.1



# RED Wash 2 • 36

## *Table of contents*

<b>1. Safety instructions</b>	<b>4</b>
<b>2. Operating determinations</b>	<b>4</b>
<b>3. Description of the device</b>	<b>5</b>
<b>4. Installation</b>	<b>6</b>
<i>4.1 Mounting the fixture</i>	<i>6</i>
<i>4.2 Connection to the mains</i>	<i>7</i>
<i>4.3 DMX-512 connection/connection between fixtures</i>	<i>7</i>
<i>4.4 Fitting the frost filter</i>	<i>8</i>
<b>5. REDWash 2•36 - DMX protocol,version 1.0</b>	<b>9</b>
<b>6. REDWash 2•36 - Control menu map</b>	<b>11</b>
<b>7. Functions of the control panel</b>	<b>12</b>
<i>7.1 Fixture Address</i>	<i>12</i>
<i>7.2 Fixture informations</i>	<i>12</i>
<i>7.3 Personality</i>	<i>12</i>
<i>7.4 Manual mode</i>	<i>13</i>
<i>7.5 Test sequences</i>	<i>14</i>
<i>7.6 Reset function</i>	<i>15</i>
<i>7.7 Special functions</i>	<i>15</i>
<b>8. Power down mode</b>	<b>16</b>
<b>9. Error and information messages</b>	<b>16</b>
<b>10. Technical specifications</b>	<b>17</b>
<b>11. Maintenance and cleaning</b>	<b>18</b>

**CAUTION! Keep this device away from rain and moisture!  
Unplug mains lead before opening the housing!**

**FOR YOUR OWN SAFETY, PLEASE READ THIS USER MANUAL CAREFULLY  
BEFORE YOU INITIAL START - UP!**

## 1. Safety instructions

Every person involved with installation and maintenance of this device have to:

- be qualified
- follow the instructions of this manual

**CAUTION! Be careful with your operations. With a high voltage you can suffer a dangerous electric shock when touching the wires!**

This device has left our premises in absolutely perfect condition. In order to maintain this condition and to ensure a safe operation, it is absolutely necessary for the user to follow the safety instructions and warning notes written in this manual.

### **Important:**

The manufacturer will not accept liability for any resulting damages caused by the non-observance of this manual or any unauthorized modification to the device.

Please consider that damages caused by manual modifications to the device are not subject to warranty.

Never let the power-cord come into contact with other cables! Handle the power-cord and all connections with the mains with particular caution!

Make sure that the available voltage is not higher than stated on the rear panel.

Always plug in the power plug least. Make sure that the power-switch is set to off -position before you connect the device to the mains. The power plug has to be accessible after installing the device.

Make sure that the power-cord is never crimped or damaged by sharp edges. Check the device and the power-cord from time to time.

Always disconnect from the mains, when the device is not in use or before cleaning it. Only handle the power cord by the plug. Never pull out the plug by tugging the power-cord.

This device falls under protection class I. Therefore it is essential to connect the yellow/green conductor to earth.

The electric connection, repairs and servicing must be carried out by a qualified employee.  
Do not connect this device to a dimmer pack.

During the initial start-up some smoke or smell may arise. This is a normal process and does not necessarily mean that the device is defective.

Do not touch the device's housing bare hands during its operation (housing becomes hot)!

**CAUTION ! EYEDAMAGES !  
Avoid looking directly into the light source (meant especially for epileptics) !**

## 2. Operating determinations

This device is a moving-head spot for creating decorative effects and was designed for indoor use only.

If the device has been exposed to drastic temperature fluctuation (e.g. after transportation), do not switch it on immediately. The arising condensation water might damage your device. Leave the device switched off until it has reached room temperature.

Do not shake the device. Avoid brute force when installing or operating the device.

Never lift the fixture by holding it at the projector-head, as the mechanics may be damaged. Always hold the fixture at the

transport handles.

When choosing the installation-spot, please make sure that the device is not exposed to extreme heat, moisture or dust. There should not be any cables lying around. You endanger your own and the safety of others!

The minimum distance between light-output and the illuminated surface must be more than 0.8 meter.

Make sure that the area below the installation place is blocked when rigging, derigging or servicing the fixture.

Always fix the fixture with an appropriate safety rope. Fix the safety rope at the correct holes only.

Only operate the fixture after having checked that the housing is firmly closed and all screws are tightly fastened.

The maximum ambient temperature 40° C must never be exceeded.

Operate the device only after having familiarized with its functions. Do not permit operation by persons not qualified for operating the device. Most damages are the result of unprofessional operation!

Please use the original packaging if the device is to be transported.

Please consider that unauthorized modifications on the device are forbidden due to safety reasons!

If this device will be operated in any way different to the one described in this manual, the product may suffer damages and the guarantee becomes void. Furthermore, any other operation may lead to dangers like short-circuit, burns, electric shock, etc.

### 3. Description of the device

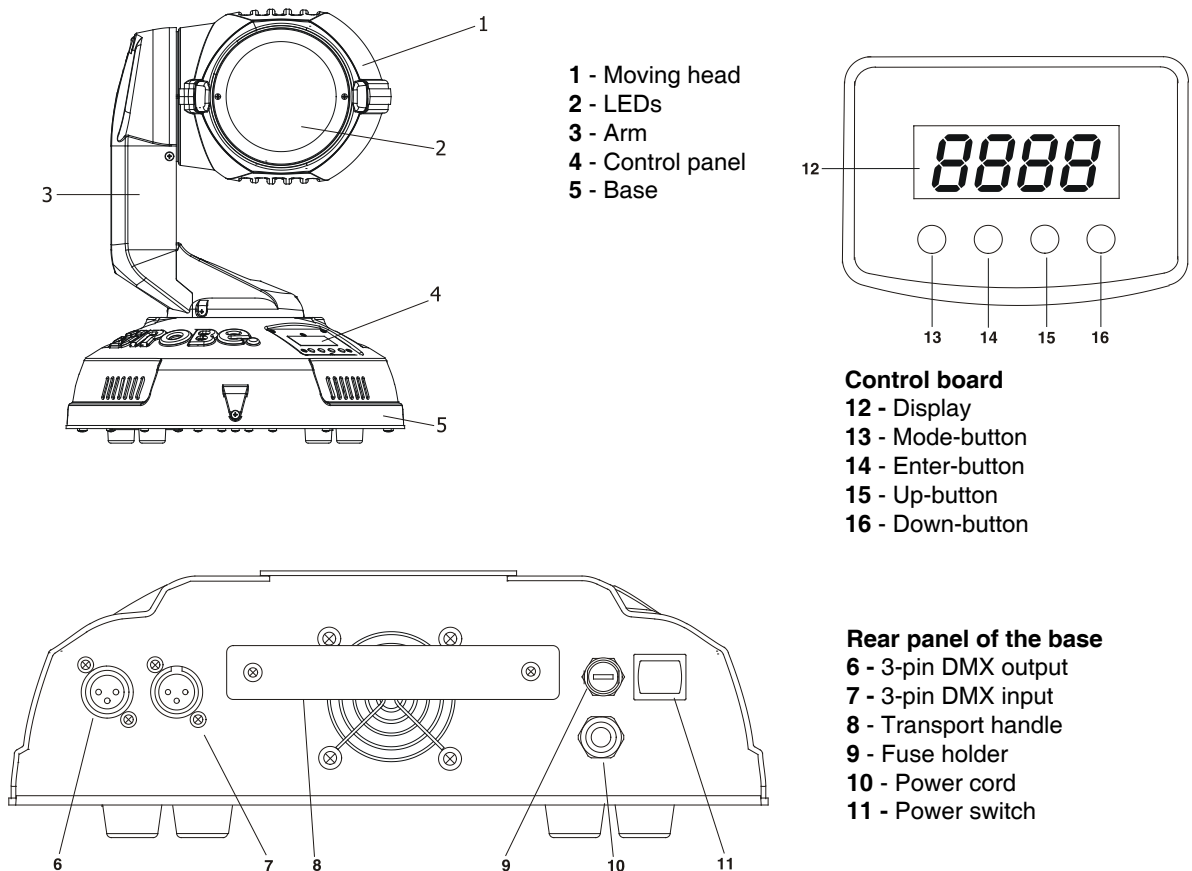

## 4. Installation

### 4.1 Mounting the fixture

**Warning !** Use 2 clamps to mount the fixture on the truss.  
Follow the instructions mentioned at the bottom of the base.  
Make sure that the device is fixed properly!  
Ensure that the structure (truss) to which you are attaching the fixtures is secure.

The moving-head can be placed directly on the stage floor or rigged in any orientation on a truss without altering its operation characteristics.

The installation of the projector has to be built and constructed in a way that it can hold 10 times the weight for 1 hour without any harming deformation.

The installation must always be secured with a secondary safety attachment, e.g. an appropriate catch net. This secondary safety attachment must be constructed in a way that no part of the installation can fall down if the main attachment fails. When rigging, derigging or servicing the fixture staying in the area below the installation place, on bridges, under high working places and other endangered areas is forbidden.

For overhead use, always install a safety-rope that can hold at least 10 times the weight of the fixture. You must only use safety ropes with screw-on carabines. Pull the safety-rope through the two apertures on the bottom of the base and over the trussing system etc. Insert the end in the carabine and tighten the fixation screw.

#### Fixation via Omega holders

1. Bolt the clamp (1) to the omega holder (4) with M12 bolt and lock nut through the hole in the holder.
2. Fasten the omega holders to the bottom of the base by inserting both quick-lock fasteners (3) into the holes of the base and tighten fully clockwise.
3. Fasten the safety-rope (2) through the two apertures on the bottom of the base and over the trussing system.

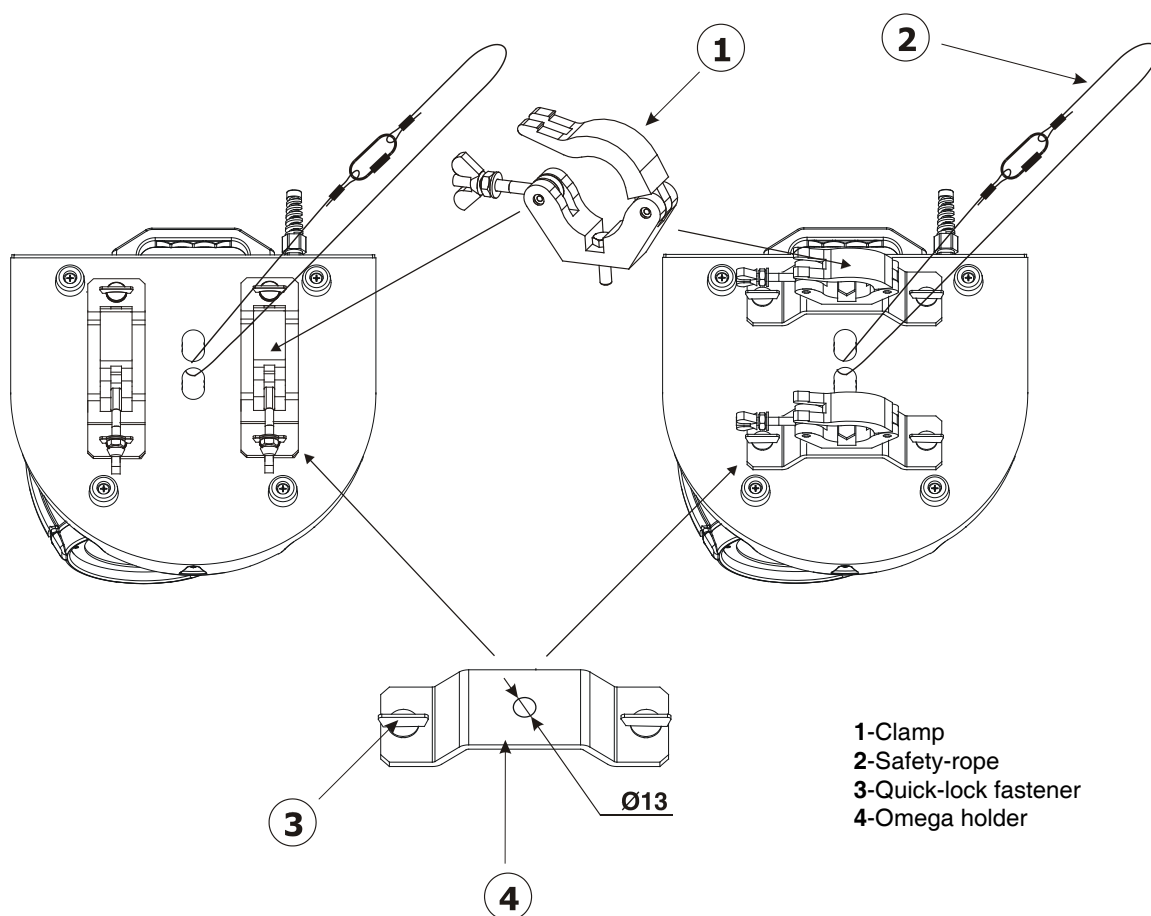

## 4.2 Connection to the mains

Connect the fixture to the mains with the power cord.

If the plug on the flexible cord is not the right type for your socket outlets, do not use an adaptor, but remove the plug from the cord and discard. Carefully prepare the end of the supply cord and fit a suitable plug. The earth has to be connected!

The occupation of the connection-cables is as follows:

Cable (EU)	Cable (US)	Pin	International
Brown	Black	Live	L
Light blue	White	Neutral	N
Yellow/ Green	Green	Earth	

## 4.3 DMX-512 connection/connection between fixtures

The fixture is equipped with 3-pin XLR sockets for DMX input and output. Only use a shielded twisted-pair cable designed for RS-485 and 3-pin XLR-plugs and connectors in order to connect the controller with the fixture or one fixture with another.

Occupation of the XLR-connection:

**DMX - output**  
XLR mounting-sockets (rear view):



- 1 - Shield
- 2 - Signal (-)
- 3 - Signal (+)

**DMX-input**  
XLR mounting-plugs (rear view):

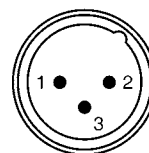

### Building a serial DMX-chain:

If you are using the standard DMX-controllers, you can connect the DMX-output of the controller directly with the DMX-input of the first fixture in the DMX-chain. If you wish to connect DMX-controllers with other XLR-outputs, you need to use adapter-cables.

Connect the DMX-output of the first fixture in the DMX-chain with the DMX-input of the next fixture. Always connect output with the input of the next fixture until all fixtures are connected.

**Caution:** At the last fixture, the DMX-cable has to be terminated with a terminator. Solder a 120 Ohm resistor between Signal (-) and Signal (+) into a 3-pin XLR-plug and plug it in the DMX-output of the last fixture.

### Building a master/slave-chain:

Connect the DMX-output of the master fixture in the data-chain with the DMX-input of the first slave. Always connect output with the input of the next slave until all slaves are connected (up to 32 fixtures).

**Caution:** It's necessary to insert the XLR termination plug (with 120 Ohm) into the input of the master fixture and into the output of the last slave fixture in the link in order to ensure the proper transmission on the data link.

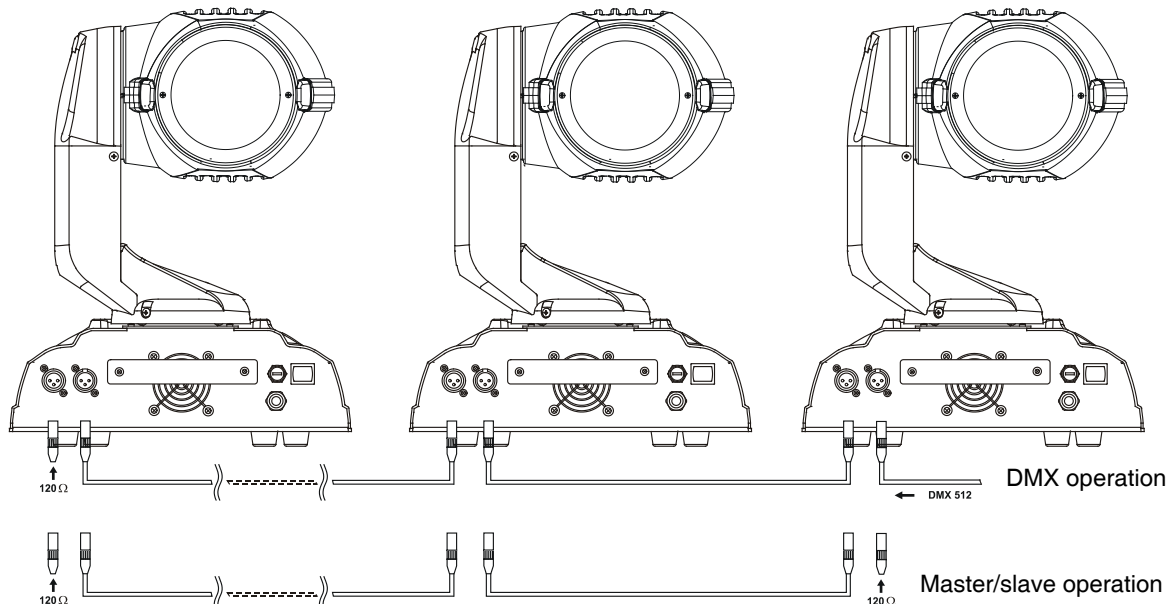

#### 4.4 Fitting the frost filter

The REDWash 2•36 is supplied with clear front glass (factory fitted) and two types of frost filters (films). If you wish to use a diffusive light, follow the steps to install desired frost filter:

1. Remove the ring (1) from the forefront of the head by loosening both fastening screws (2).

2. Put the frost film on the front glass and centre the holes in the film on the holes in the holder of the glass.

3. Put the ring carefully back and tighten both fastening screws.

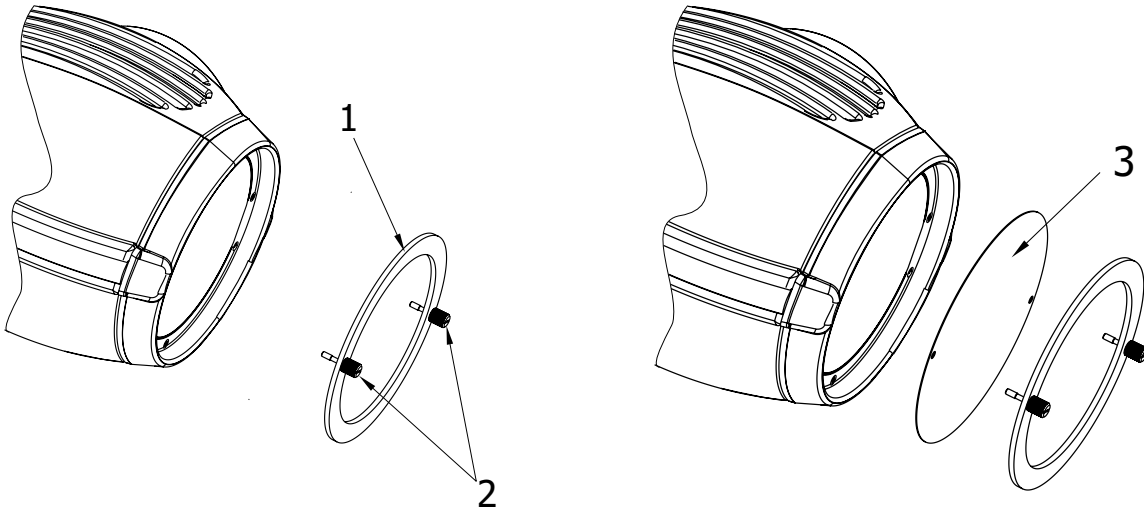



## 5. REDWash 2•36 - DMX protocol,version 1.0

Mode 1 Channel	Mode 2 Channel	Value	Function	Type of control
1	1	0 - 255	<b>Pan</b> Pan movement by 530°	proportional
2		0 - 255	<b>Pan Fine</b> Fine control of pan movement	proportional
3	2	0 - 255	<b>Tilt</b> Tilt movement by 280°	proportional
4		0 - 255	<b>Tilt fine</b> Fine control of tilt movement	proportional
5	3	0	<b>Pan/Tilt speed, Pan/Tilt time</b> Max. speed (tracking mode)	step
		1 - 255	<b>P./T. speed-set Speed Mode in menu: P./T. Mode</b> Speed from max. to min. (vector mode)	proportional
		1 - 255	<b>P./T. time - set Time Mode in menu: Pan/Tilt Mode</b> Time from 0,1 s to 25.5 s.	proportional
6		0 - 9	<b>Pan/Tilt macro selection</b> Disabled pan/tilt macro	step
		10 - 31	Reserved	step
		32 - 63	Figure of circle (from small to large)	proportional
		64 - 95	Figure of horizontal eight (from small to large)	proportional
		96 - 127	Figure of vertical eight (from small to large)	proportional
		128 - 159	Figure of rectangle (from small to large)	proportional
		160 - 191	Figure of triangle (from small to large)	proportional
		192 - 223	Figure of five-pointed star (from small to large)	proportional
224 - 255	Figure of cross (from small to large)	proportional		
7		0	<b>Pan/Tilt macro speed</b> <i>Set pan/tilt speed (channel 5) at 0 DMX</i>	step
		1-127	No macro generation	proportional
		128-129	Macro generation from fast to slow-forwards	step
		130-255	Macro generation from slow to fast-backwards	proportional
8		0 - 129	<b>Special functions</b> Reserved	step
		130 - 139	Pan/tilt reset	
		140 - 255	Reserved	
9	4	0-255	<b>Red LED</b> Red LED saturation control (0-100%)	proportional
10	5	0-255	<b>Green LED</b> Green LED saturation control (0-100%)	proportional
11	6	0-255	<b>Blue LED</b> Blue LED saturation control (0-100%)	proportional
12		0-7	<b>Colour MACRO SELECTION</b> No function	step
		8-15	Macro 1	step
		16-23	Macro 2	step
		24-31	Macro 3	step
		32-39	Macro 4	step
		40-47	Macro 5	step
		48-55	Macro 6	step
		56-63	Macro 7	step
		64-71	Macro 8	step
		72-79	Macro 9	step
		80-87	Macro 10	step
		88-95	Macro 11	step
		96-103	Macro 12	step
		104-111	Macro 13	step
		112-119	Macro 14	step
		120-127	Macro 15	step
128-135	Macro 16	step		

Mode 1 Channel	Mode 2 Channel	Value	Function	Type of control
12		136-143	Macro 17	step
		142-151	Macro 18	step
		152-159	Macro 19	step
		160-167	Macro 20	step
		168-175	Macro 21	step
		176-183	Macro 22	step
		184-191	Macro 23	step
		192-199	Macro 24	step
		200-207	Macro 25	step
		208-215	Macro 26	step
		216-223	Macro 27	step
		224-231	Macro 28	step
		232-239	Macro 29	step
		240-247	Macro 30	step
248-255	Macro 31-Rainbow effect	step		
13	7	0-31	<b>SHUTTER/STROBE</b> Shutter closed	step
		32-63	Shutter open	step
		64-95	Strobe-effect from slow to fast	proportional
		96-127	Shutter open	step
		128-143	Opening pulses in sequences slow--> fast	proportional
		144-159	Closing pulses in sequences fast --> slow	proportional
		160-191	Shutter open	step
		192-223	Random strobe-effects from slow to fast	proportional
		224-255	Shutter open	step
14	8	0-255	<b>DIMMER</b> Dimmer intensity from 0% to 100%	proportional

## 5. REDWash 2•36 - Control menu map

Default settings=Bold print

**A001** (001-498)

**InFo**

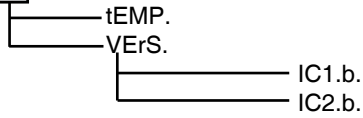

**PErS.**

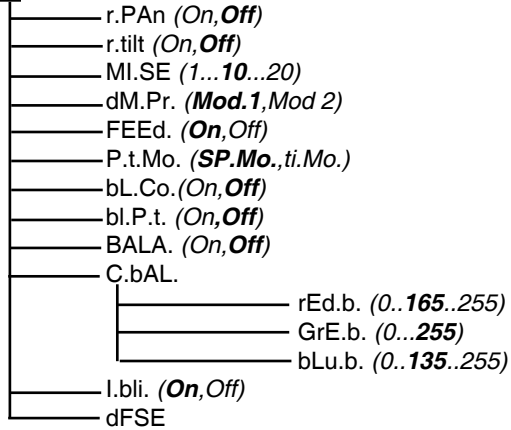

**MAn.C.**

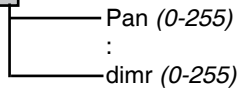

**tESt**

**St.AL.**

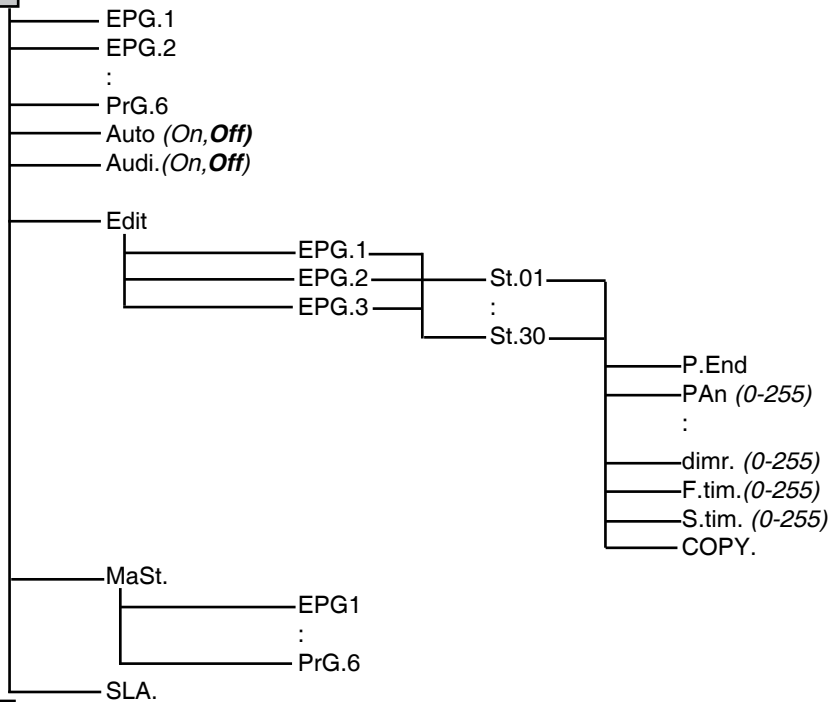

**rESE.**

**SPEC.**



## 7. Functions of the control panel

The control panel situated on the front panel of the base offers several features. You can simply set the DMX address, run programs, make a reset and also use many functions for setting the fixture behaviour.

### Control elements on the control board:

[MODE] button-leaves menu without saving changes.

[ENTER] button- enters menu,confirms adjusted values and leaves menu.

[UP] button and[DOWN] button- moves between menu items on the the same level, sets values.

After switching the fixture on,the display shows the initial screen:



Use [UP],[DOWN] to browse through the menu. To select a function or submenu,press [ENTER].

### 7.1 Fixture Address



Use this menu to set the DMX start address of the fixture, which is defined as the first channel from which the REDWash 2•36 will respond to the controller.

If you set, for example, the address 15, the REDWash 2•36 will use the channel 15 to 28 for control (if Mode 1 is selected).

Please, be sure that you don't have any overlapping channels in order to control each REDWash 2•36 correctly and independently from any other fixture on the DMX data link.

If two, three or more REDWash 2•36 are addressed similarly, they will work similarly.

After having addressed all REDWash 2•36, you may now start operating these via your lighting controller.

**Note:** After switching on, the REDWash 2•36 will automatically detect whether DMX 512 data is received or not.

If there is no data received at the DMX-input, the display will start to flash „A001” with actually set address.

#### This situation can occur if:

- the 3 PIN XLR plug (cable with DMX signal from controller) is not connected with the input of the REDWash 2•36.
- the controller is switched off or defective, the cable or connector is defective or the signal wires are swap in the input connector.

**Note:** It's necessary to insert the XLR termination plug (with 120 Ohm) to the last fixture in the link in order to ensure proper transmission on the DMX data link.

### 7.2 Fixture informations



Use this menu to read an useful information about the fixture.

**TEMP** ---**Fixture temperature.**The function shows the temperature in the fixture head (°C).Please note that the outside temperature should not exceed 40° C.

**VERs.** --- **Software version.**Select this function to read the software version of processors:

**IC1.b.**--- Main processor on the main board in the fixture base

**IC2.b.**--- Pan/tilt processor on the main board in the fixture base

### 7.3 Personality



Use this menu to to modify the REDWash 2•36 operating behavior.

**r.PAn** --- **Pan reverse.**Select this function to invert the pan movement.

**r.tilt** --- **Tilt reverse.**Select this function to invert the tilt movement.

**DM.Pr.** --- **DMX preset.**Select this item to choose desired DMX mode.Please refer to the chapter "DMX protocol" for detail description.

**Mi.SE.** --- **Microphone sensitivity.**Select this function to adjust the microphone sensitivity from 1(maximum) to 20(minimum).If the sensitivity is correctly adjusted,the upper segment of the first digit blinks in the bass beat.

Examples:



underexited



right level  
(upper segment blinks)



overexited

**FEEd** --- **Pan/Tilt feedback.**This function allows to return the mowing head to the required pan/tilt position after changing the position by external force (e.g.by stroke).

**Be careful, the Pan/Tilt Feedback OFF is not the standard operation and the head of the fixture can be damaged!**

Note: If the feedback was switched off ,the pan/tilt-position is changed by an external force and the feedback is switched on again,the moving head might not to be synchronized with the DMX signal.You have to make a reset in order to synchronize the moving head with the DMX signal.

**P.t.Mo.** --- **Pan/tilt movement mode.**Use this menu to set the character of the pan/tilt movement.

**ti.Mo.** --- **Time mode.**Pan and tilt will move with different speeds and they will come at the same time to end point (pan and tilt sets its optimal speed).

**SP.Mo.** --- **Speed mode.**Pan and tilt will move with the same speed as adjusted at the channel 5 (Pan/Tilt speed).E.g. pan will come to the end point and wait for tilt,which has longer track.

**bl.Co.** --- **Blackout during movement correction.**Select this function to enable the blackout during the head movement correction (if the moving head lost its right pan/tilt position for a short moment).

**bl.P.t.** --- **Active Blackout while Pan/Tilt moving:** - Use this function if you wish to close the light output during pan/tilt changes.

**bALA.** --- **Balance.**Select this function to enable (On) or disable (OFF) the white balance which is set in "White colour balance" menu below.If this function is set OFF,REDWash 2•36 will use maximum values (255) of saturation for red, green and blue channel.

**C.bAL.** --- **White colour balance.** Using this menu you can set the white balance:

1. Browse through the menu by pressing the [UP] and [DOWN] buttons until the display shows "C.bAL." menu.Press [ENTER] button and "rEd.b." will appear on the display.

2.Press [ENTER] button again and use [UP] and [DOWN] buttons to adjust the new maximum value required for the red channel.Confirm your choice by pressing [ENTER].Use the [UP] and [Down] buttons to select next colour.

3.Repeat step 2 for green channel "GrE.b." and for blue channel "bLu.b".

**i.bLi.** --- **Initial blink.**If this function is on,REDWash 2•36 makes auto-calibration (All LEDs light on 100% for a short time) after switching the fixture on.If this function is set off,you have to set manually every colour on max.brightness after switching on the driver before starting regular operating.This action should last min. one second for every colour.

**dF.SE.** --- **Default Settings** .Select this option to reset all fixture personalities to the factory values.

## 7.4 Manual mode



Select this menu to control channel effects by control buttons on the control board without an external controller.

**PAn** a coarse pan movement

**F.PAn** a fine pan movement

**tilt** a coarse tilt movement

**F.tilt** a fine tilt movement

**SpEd** a pan/tilt speed

**P.t.SE.** a pan/tilt macro selection

**P.t.SP.** a pan/tilt speed

**Func.** a special function

**rED** a red LED saturation

**GrEE** a green LED saturation

**bLuE** a blue LED saturation

**MACr** a colour macros

**Stro.** a strobe,shutter

**dimr** a dimmer

## 7.5 Test sequences



Use this menu to to run a demo-test sequences without an external controller, which will show you some possibilities of using REDWash 2•36.

## 7.6 Stand-alone setting



The fixtures on a data link are not connected to the controller but can execute pre-set programs which can be different for every fixture. "Stand-alone operation" can be applied to the single fixture or to multiple fixtures operating synchronously. Synchronous operation of multiple fixtures requires that they must be connected on a data link and one of them is set as a master ("MSt") and the rest as the slaves ("SLA"). Up to 32 fixtures can be connected in master/slave chain. Only one fixture can be set as the master.

**Note:** Disconnect the fixtures from the DMX controller before master/slave operating, otherwise data collisions can occur and the fixtures will not work properly!

It's necessary to insert the XLR termination plug (with 120 Ohm) into the input of the master fixture and into the output of the last slave fixture in the data link in order to ensure proper transmission on the data link.

### Operating multiple fixtures in stand-alone mode.

1. Select one fixture and set it as a master and select a program which is to be played (Menu path: "St.AL."---->"MASt.").
2. The rest of the fixtures set as slaves (Menu path: "St.AL."---->"SLA.").
3. Build the master/slave chain. (See chapter "DMX-512 connection and Master/Slave connection").

**Audi --- Music trigger.** Select this function to enable the sound control of the running programs via the built-in microphone.

**EPG1-PrG.6 --- Fixture programs.** By pressing [ENTER] selected program will run in a loop.

**Auto. --- Automatically playback.** If this function is on, the fixture in DMX mode remembers last running program and this program will run after switching the fixture on.

**Edit --- Editing program.** The fixture includes 6 built-in programs (PrG.1-PrG.6) and 3 free editable programs (EPG.1-EPG.3) each up to 30 steps. Every program step has a fade time-the time during which effects (except pan/tilt) go to the current step and a standing time-the time, during which effects last in the current step.

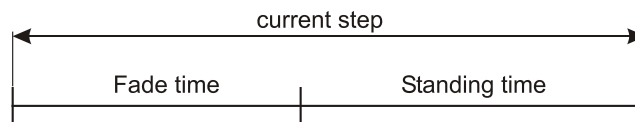

Programming procedure:

1. Enter "Edit." menu
2. Press [UP] or [DOWN] to select the desired program which you wish to edit and press [ENTER].
3. Press [UP] or [DOWN] to select the desired program step ("St.01" - "St.30") and press [ENTER].
4. Press [UP] or [DOWN] to select the desired item and press [ENTER] button. Now you can edit by using [UP] or [DOWN] buttons the DMX values of selected item:

**P.End.** - a total number of the program steps (value 1-30). This value must be set before start programming (e.g. if you want to create program with 10 steps, set P.End=10).

**PAn** a coarse pan movement

**F.PAn** a fine pan movement

**tilt** a coarse tilt movement

**F.tilt** a fine tilt movement

**SpEd** a pan/tilt speed

**P.t.SE.** a pan/tilt macro selection

**P.t.SP.** a pan/tilt speed

**rED** a red LED saturation

**F.tim.** - fade time, value 0-255 \*

**S.tim.** - standing time, value 0-255 \*

**COPY.** - copying the current prog. step to the next prog. step.

Press [ENTER]-button to confirm adjusted value.

5. Repeat steps 3 and 4 for next prog. step. If you want to copy current prog. step to the next prog. step, select option "COPY." and confirm it by pressing [ENTER].

**GrEE** a green LED saturation

**bLuE** a blue LED saturation

**MACr** a colour macros

**Stro.** a strobe, shutter

**dimr** a dimmer

\*Both Fade time and Standing time use the same conversion table in order to convert DMX value to the time value:

DMX	Time [sec.]	DMX	Time [min.]	DMX	Time [min.]	DMX	Time [min.]	DMX	Time [min.]
1	0.1	50	4.2	105	18.4	160	42.7	215	77
2	0.4	55	5	110	20.2	165	45.4	220	80.7
5	2.5	60	6	115	22	170	48.2	225	84.4
10	10	65	7	120	24	175	51	230	88.2
15	22.5	70	8.2	125	26	180	54	235	92
20	40	75	9.4	130	28.2	185	57	240	96
25	62.5	80	10.7	135	30.4	190	60.2	245	100
30	90	85	12	140	32.7	195	63.4	250	104
35	122.5	90	13.5	145	35	200	66.7	255	108
40	160	95	15	150	37.5	205	70		
45	202.5	100	16.7	155	40	210	73.5		

Exact expression of the time value follows the equation: time[sec.]=(DMX value)<sup>2</sup>/10.

**MASt.** --- **Master.** Enter this menu if you want to set the the fixture as a master. Use [UP] and [DOWN] buttons to select desired program and press [ENTER] to confirm selection.

**SLA.** --- **Slave.** Select this menu if you want to set the the fixture as a slave.

## 7.6 Reset function



This option enables the REDWash 2•36 to index all effects and return them to their standard positions.

## 7.7 Special functions



Use this menu for special services like software update.

**uPd.M.** --- **Updating mode.** Using this function you can update software in the fixture via PC and serial link.

The following are required in order to update software:

- PC running Windows 95/98/2000/XP or Linux
- DMX Software Uploader
- Flash cable RS232/DMX (No.13050624)

**Note1:** Software update should execute a qualified person. If you lack qualification, do not attempt the update yourself and ask for help your ROBE distributor.

**Note 2:** DMX address, IP address ,programs 1-3 and all functions in menu "PErS" will be set to their default values.

### To update software in the fixture:

#### 1. Installation of DMX Software Uploader.

1. DMX Software Uploader program is available from the ROBE web site at [WWW.robe.cz](http://WWW.robe.cz).
2. Make a new directory ( e.g. Robe\_Uploader) on your hard disk and download the software to it.
3. Unpack the program from the archive. If the Robe fixture is produced in magnetic and electronic ballast version, name of DMX Software Uploader is the same for both versions.

#### 2. Fixture software updating.

1. Determine which of your COM port is available on your PC and connect it with to the DMX input of the fixture using the uploading cable. Do not extend this cable! Disconnect the fixture from the other fixtures in DMX chain! Turn on the computer and the fixture.
2. Switch the fixture to the update mode by selecting the option Updating mode in menu SPEC. Functions on the fixture control panel: SPEC-->UPd-->yES. (From this option you cannot return back to the main menu. If you do not want to continue in software update, you have to switch off and on the fixture to leave this option!)
3. It is recommended that you exit all programs before running the Software Uploader.

4. Start the Software Uploader program. Select desired COM and then click Connect button. If the connection is OK, click Start Uploading button to start uploading. It will take several minutes to perform software update. If the option "Incremental Update" isn't checked, all processors will be updated (including processors with the same software version). If you wish to update only later versions of processors, enable the Incremental Update check box. Avoid interrupting the process. Update status is being displayed in the list window. When the update is finished, the line with the text "The fixture is successfully updated" will appear in this window and the fixture will reset with the new software.

Note: In the case of interruption of the upload process (e.g. power cut), the fixture remains in the update mode and you have to repeat the software update again.

For example: The fixture was switched off before finishing software upload. After switching the fixture on again, the fixture is still in the update mode and the display is dark. Restart the Software Uploader program and repeat software update from your PC.

## 8. Power down mode

This mode omits fixture reset after switching the fixture on and lowers motor powers of the fixture. „Power down mode” is useful in special cases, e.g. if the fixture is in a flight case and you want to set its DMX address without taking it out from the case. To enter „Power down mode”, press and hold [UP] and [DOWN] and at the same time switch on the Power switch. The following message appears on the display: "P.d.Mo."

Press [ENTER] to activate „Low power mode” without fixture reset. Now you can set features and behaviour of the fixture by using "Pers." menu. If you want to go „normal operation mode”, execute fixture reset.

Note: All motors in "Power down mode" are deactivated.

## 9. Error and information messages

### ***PA.Er.*** (Pan-yoke movement error)

This message will appear after the reset of the fixture if the yoke's magnetic-indexing circuits malfunction (sensors failed or magnet missing) or the stepping motor is defective. (Or its driving IC on the main PCB). The yoke is not located in the default position after the reset.

### ***ti.Er.*** (TILT-head movement error)

This message will appear after the reset of the fixture if the head's magnetic-indexing circuit malfunctions (sensor failed or magnet missing) or the stepping motor is defective. (Or its driving IC on the main PCB). The head is not located in the default position after the reset.



# 10. Technical specifications

## Power supply

- Input Voltage:100-240V AC, 50/60 Hz
- Fuse:T 2 A
- Max.Pover Consumption:180 VA

## Optical system

- 36 RGB Luxeon K2 LEDs
- Standard 6° beam angle lenses
- Optional 25° beam angle lenses

## Beam path

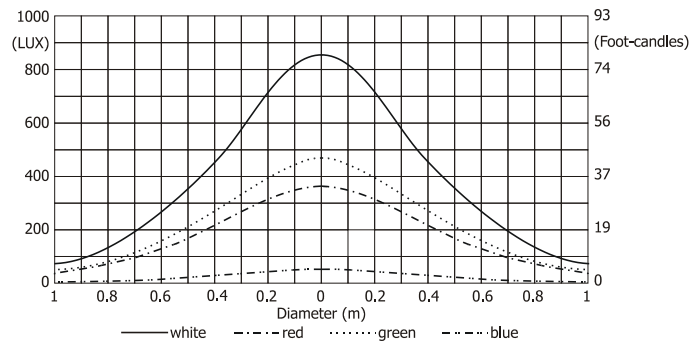
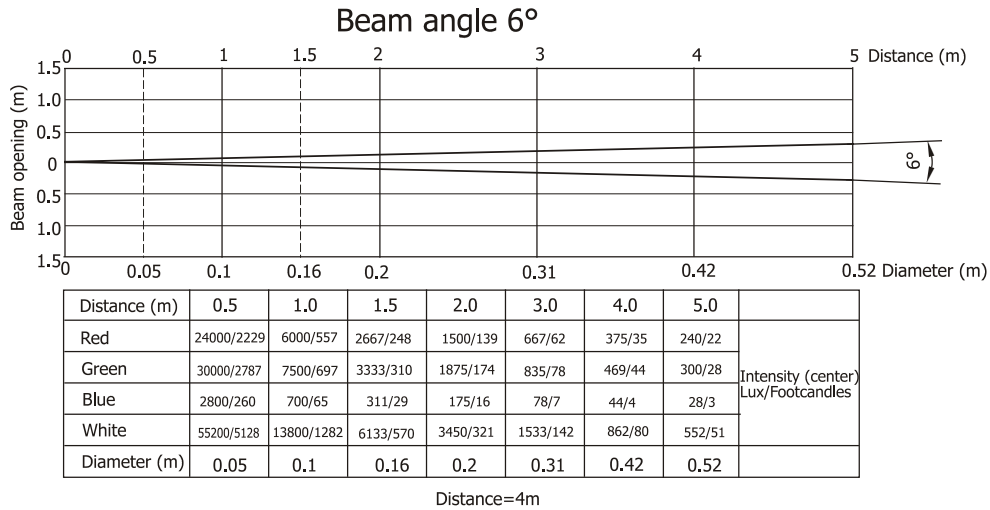

## Strobe

- Strobe effect with variable speed (max. 25 flashes per second)
- Preprogrammed random strobe pulse-effects

## Dimmer

- Smooth dimmer from 0 - 100 %

## Motors

- 2 high quality stepping motors controlled by microprocessors

## Electronics

- Addressing, special functions setting, manual control via control panel with 4-digit LED display
- Built-in analyzer for easy fault finding, error messages
- Built-in demo sequences
- Black-out while head moving
- Silent fans cooling
- Digital serial input DMX-512
- Master/slave operation
- DMX-control via every standard DMX controller
- control channels: 8 or 14

### Pan/Tilt

- Pan movement range 530°
- Tilt movement range 280°
- 8/16 bit movement resolution
- Automatic pan/tilt position correction
- Remotely controllable speed of pan/tilt movement for easy programming

### Rigging

- Stands directly on the floor
- Mounts horizontally or vertically with 2 Omega holders
- 2 truss orientation
- Safety cord attachment point

### Data input/output

- 3-pin XLR male socket for DMX data input
- 3-pin XLR female socket for DMX data output

### Temperatures

- Maximum ambient temperature: 40° C
- Maximum housing temperature: 65° C

### Minimum distances

- Min. distance from flammable surfaces: 0.5 m
- Min. distance to lighted object: 0.7 m

### Dimensions

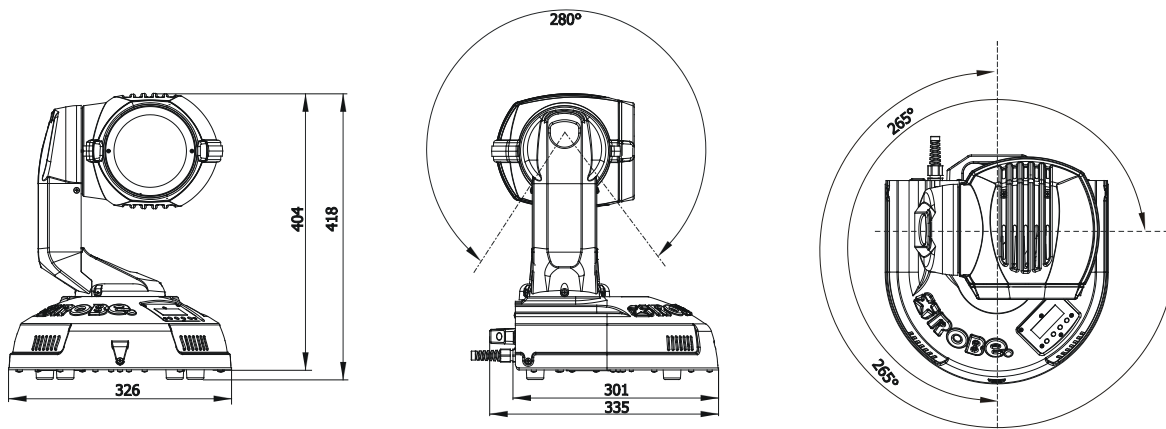

### Weight (net)

8.8 kg

### Accessories

- Mounting bracket Omega CL assembled (2 pieces) .....No. 99010420
- Frost film filter (soft).....No. 14060091
- Frost film filter (dense).....No. 14060092

### Optional accessories:

- Flash cable RS232/DMX .....No.13050624

## 11. Maintenance and cleaning

It is absolutely essential that the fixture is kept clean and that dust, dirt and smoke-fluid residues must not build up on or within the fixture. Otherwise, the fixture's light-output will be significantly reduced. Regular cleaning will not only ensure the maximum light-output, but will also allow the fixture to function reliably throughout its life.

A soft lint-free cloth moistened with any good glass cleaning fluid is recommended, under no circumstances should alcohol or solvents be used!

### ***DANGER !***

***Disconnect from the mains before starting any maintenance work***

The front objective glass will require weekly cleaning as smoke-fluid tends to building up residues, reducing the light-output very quickly. The cooling-fans should be cleaned monthly.

The interior of the fixture should be cleaned at least annually using a vacuum-cleaner or an air-jet.

More complicated maintenance and service operations are only to be carried out by authorized dealers.

### **Replacing the fuse**

If the lamp burns out, the fine-wire fuse of the device might fuse, too. Only replace the fuse by a fuse of same type and rating. Before replacing the fuse, unplug mains lead.

### **Procedure:**

- 1) Unscrew the fuseholder on the rear panel of the base with a fitting screwdriver from the housing (anti clockwise).
- 2) Remove the old fuse from the fuseholder.
- 3) Install the new fuse in the fuseholder.
- 4) Replace the fuseholder in the housing and fix it.