

# Color Mix **575** AT

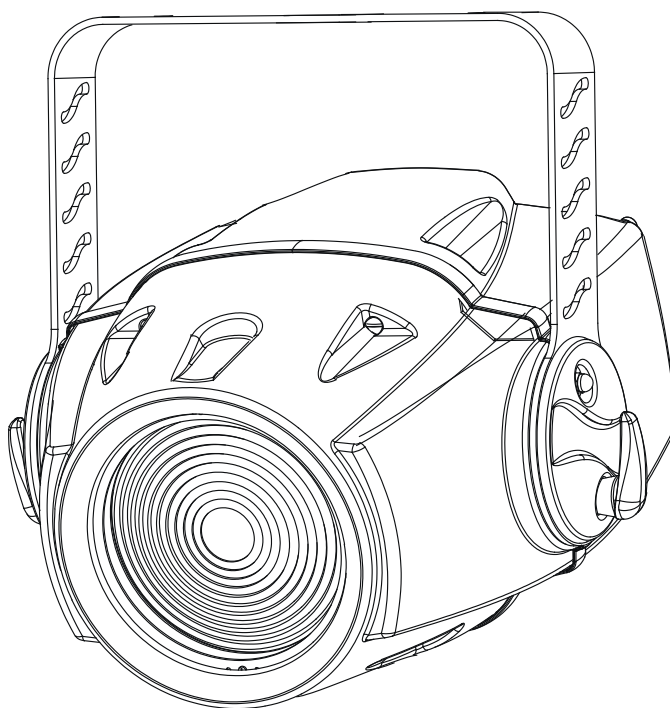

**AT** series

Version 2.1

**USER MANUAL**

# ColorMix 575 AT

## Table of contents

<b>1. Safety instructions</b> .....	<b>3</b>
<b>2. Operating determinations</b> .....	<b>4</b>
<b>3. Description of the device</b> .....	<b>5</b>
<b>4. Installation</b> .....	<b>6</b>
4.1 Fitting/Exchanging the lamp .....	6
4.2 Lamp adjustment .....	6
4.3. Changing the power supply settings .....	7
4.4 Rigging .....	8
4.5 Connection to the mains .....	10
4.6 DMX 512 connection, master/slave connection .....	11
4.7 Installation of the barn-doors .....	12
4.8 Changing the front lens .....	12
<b>5. DMX Protocol</b> .....	<b>13</b>
<b>6. Controller mode</b> .....	<b>16</b>
6.1 DMX addressing .....	16
6.2 Remotely controllable functions .....	16
<b>7. Stand - alone mode</b> .....	<b>17</b>
<b>8. Control menu map</b> .....	<b>18</b>
<b>9. Functions of the control panel</b> .....	<b>21</b>
9.1 Fixture Address .....	21
9.2 Slave control .....	21
9.3 Fixture informations .....	21
9.4 Personality .....	23
9.5 Lamp On/Off .....	23
9.6 Manual mode .....	24
9.7 Test sequences .....	24
9.8 Stand-alone setting .....	24
9.9 Reset functions .....	25
9.10 Special functions .....	25
<b>10. Low power mode</b> .....	<b>26</b>
<b>11. Error and information messages</b> .....	<b>26</b>
<b>12. Technical specifications</b> .....	<b>27</b>
<b>13. Maintenance and cleaning</b> .....	<b>29</b>

**CAUTION!**  
**Keep this device away from rain and moisture!**  
**Unplug mains lead before opening the housing!**

**FOR YOUR OWN SAFETY, PLEASE READ THIS USER MANUAL CAREFULLY  
BEFORE YOU INITIAL START - UP!**

## 1. Safety instructions

**Caution ! Be careful with your operations. With a dangerous voltage you can  
suffer a dangerous electric shock when touching the wires**

This device has left our premises in absolutely perfect condition. In order to maintain this condition and to ensure a safe operation, it is absolutely necessary for the user to follow the safety instructions and warning notes written in this manual.

### **Important:**

Damages caused by the disregard of this user manual are not subject to warranty. The dealer will not accept liability for any resulting defects or problems.

If the device has been exposed to drastic temperature fluctuation (e.g. after transportation), do not switch it on immediately. The arising condensation water might damage your device. Leave the device switched off until it has reached room temperature.

This device falls under protection-class I. The power plug must only be plugged into a protection class I outlet.

Never let the power-cord come into contact with other cables! Handle the power-cord and all connections with the mains with particular caution!

Make sure that the available voltage is not higher than stated on the rear panel.

Make sure that the power-cord is never crimped or damaged by sharp edges. Check the device and the power-cord from time to time.

Always disconnect from the mains, when the device is not in use or before cleaning it. Only handle the power-cord by the plug. Never pull out the plug by tugging the power-cord.

During the initial start-up some smoke or smell may arise. This is a normal process and does not necessarily mean that the device is defective.

**Caution:** During the operation, the housing becomes very hot.

Do not switch the device on and off in short intervals as this would reduce the lamp's life.

**HEALTH HAZARD!**  
**Never look directly into the light source, as sensitive persons may suffer  
an epileptic shock  
( especially meant for epileptics) !**

Please consider that damages caused by manual modifications to the device are not subject to warranty.

Keep away children and amateurs !

## 2. Operating determinations

This device is a projector for creating decorative effects and was designed for indoor use only.

This device is designed for professional use, e.g. on stages, in discotheques, theatres etc.

Never run the device without lamp!

Do not shake the device. Avoid brute force when installing or operating the device.

When choosing the installation-spot, please make sure that the device is not exposed to extreme heat, moisture or dust. There should not be any cables lying around. You endanger your own and the safety of others!

The minimum distance between light-output and the illuminated surface must be more than 1,5 meter.

Make sure that the area below the installation place is blocked when rigging, derigging or servicing the fixture.

Always fix the fixture with an appropriate safety-rope.

Only operate the fixture after having checked that the housing is firmly closed and all screws are tightly fastened.

The lamp must never be ignited if the fresnel-lens or any housing-cover is open, as discharge lamps may explode .

The maximum ambient temperature must never be exceeded.

**CAUTION!**  
**The lens has to be replaced when it is obviously damaged,  
so that its function is impaired, e. g. due to cracks or deep scratches!**

Operate the device only after having familiarized with its functions. Do not permit operation by persons not qualified for operating the device. Most damages are the result of unprofessional operation!

**CAUTION!**  
**The lamp has to be replaced when it is damaged  
or deformed due to the heat!**

Please use the original packaging if the device is to be transported.

Please consider that unauthorized modifications on the device are forbidden due to safety reasons!

If this device will be operated in any way different to the one described in this manual, the product may suffer damages and the guarantee becomes void. Furthermore, any other operation may lead to dangers like short-circuit, burns, electric shock, lamp explosion, crash etc.

### 3.Description of the device

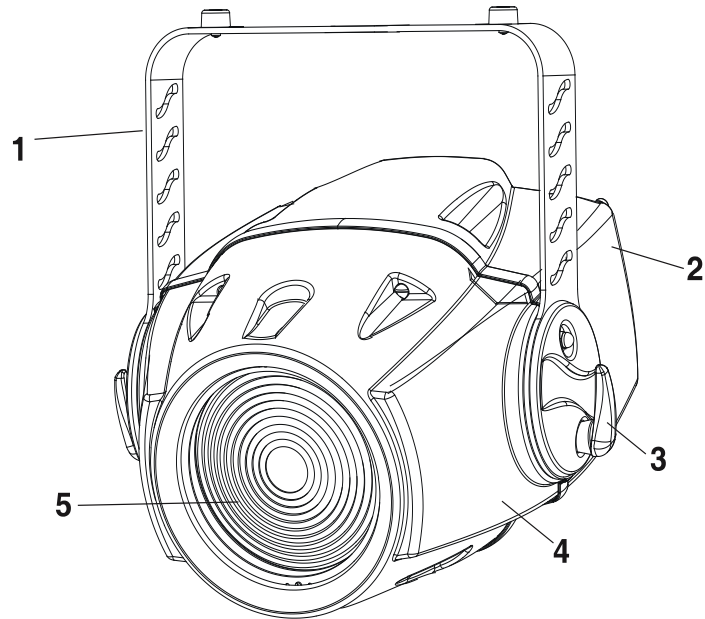

- 1 - Mounting bracket
- 2 - Rear cover
- 3 - Adjusting screw

- 4 - Front cover
- 5 - Fresnel lens

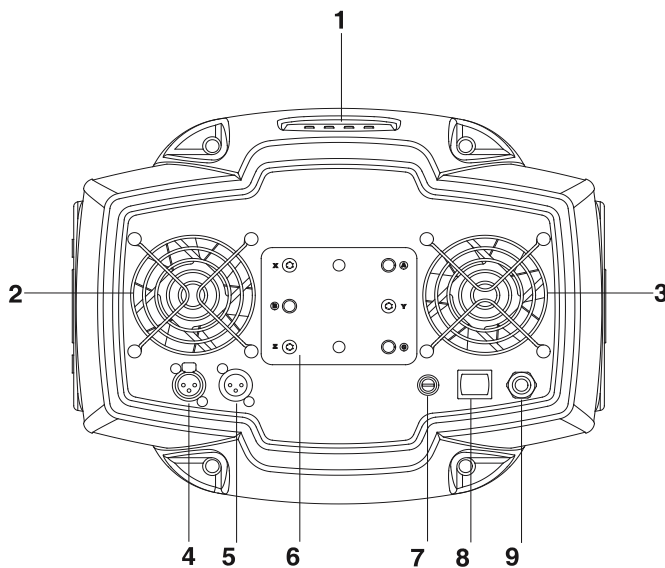

#### Rear side

- 1 - Control board
- 2,3- Fans
- 4 - DMX output
- 5 - DMX input
- 6 - Lamp cover
- 7 - Fuse holder
- 8 - Power switch
- 9 - Power cord

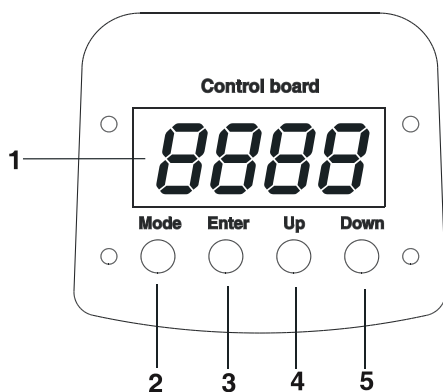

#### Control panel

- 1 - Display
- 2 - Mode-button
- 3 - Enter-button
- 4 - Up-button
- 5 - Down-button

## 4. Installation

### 4.1 Fitting/Exchanging the lamp

**DANGER !**  
**Install the lamp with the device switched off only.**  
**Unplug from mains before !**

Lamp cover:

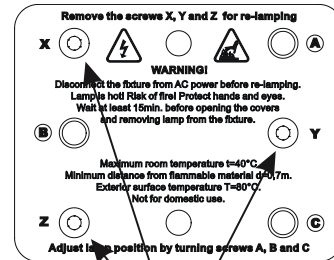
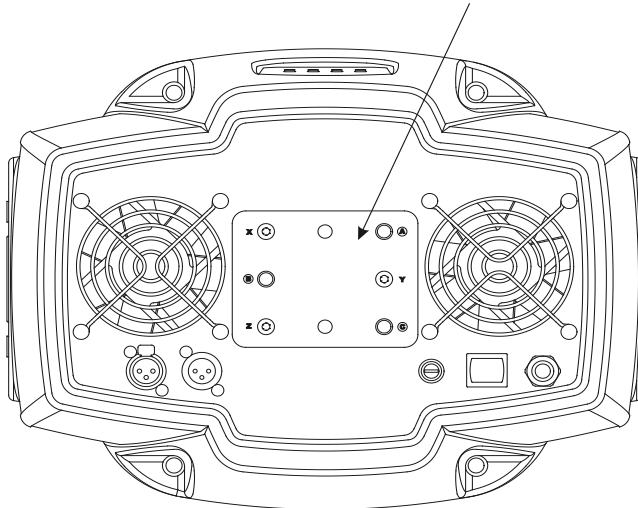

3 fastening screws

To insert the lamp MSR 575W/2 open the small cover at the rear of the projector by loosening the 3 screws „X, Y, Z” on the lamp cover.

Gently pull out the lamp socket assembly.

If changing the lamp, remove the old lamp from the socket. Insert the lamp to the socket.

Do not install a lamp with a higher wattage! A lamp like this generates temperatures the device is not designed for.

Damages caused by non-observance are not subject to warranty. Please follow the lamp manufacturer's notes!

Do not touch the glass-bulb bare hand during the installation! Make sure that the lamp is installed tightly into the lamp holder system.

Reinsert the lamp assembly and tighten the 3 screws again.

Before striking the lamp, reset the "LAti/rSEt" and "LAST/rSEt" counters in the "InFO" menu on the control panel, by pressing the [ Up ] and [ Down ] buttons in one time and then confirming with the [ Enter ] button.

**Do not operate this fixture with opened housing-cover!**

### 4.2 Lamp adjustment

The lamp holder is aligned at the factory. Due to differences between the lamps, fine adjustment may improve light performance.

Strike the lamp, cancel all effects, open the shutter and set the dimmer intensity to maximum and focus the light on a surface (wall) or use function "LAAAd" in the **Special functions** of the control board.

Center the hot-spot (the brightest part of the beam) using the 3 adjustment screws „A, B, C”. Turn one screw at a time to drag the hot-spot, diagonally across the projected image. If you cannot detect a hot-spot, adjust the lamp until the light even. To reduce a hot-spot, pull the lamp in by turning all three screws „A, B, C” clockwise 1/4-turn at a time until the light is evenly distributed. If the light is brighter around the edge than it is in the center, or if light output is low, the lamp is too far back in the projector. „Push” the lamp out by turning the screws „A, B, C” counterclockwise 1/4-turn at a time the light is bright and evenly distributed.

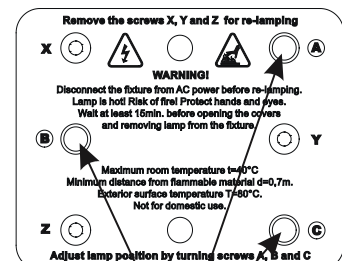

adjusting screws „A, B, C”

### 4.3. Changing the power supply settings

Both the transformer and the ballast must be connected correctly for the local AC voltage and frequency. The wrong settings can cause poor performance or damage of the moving head. The factory settings are printed next to the power switch.

**If you want to change the power supply settings, follow the instructions:**

1. Disconnect the fixture from AC power.
2. Remove the rear cover by loosening the 4 screws.
3. Move the wire (1) on the transformer connection block to the position according to the desired voltage.
4. EU version: Move the wires (2) and (3) on the ballast connection block to the position according to the desired frequency/voltage.  
US version: Move the wire (2) on the ballast connection block to the position according to the desired frequency.
5. Put the cover back before applying AC power.

**Examples:**

#### EU-version Power supply settings: 230V/50Hz

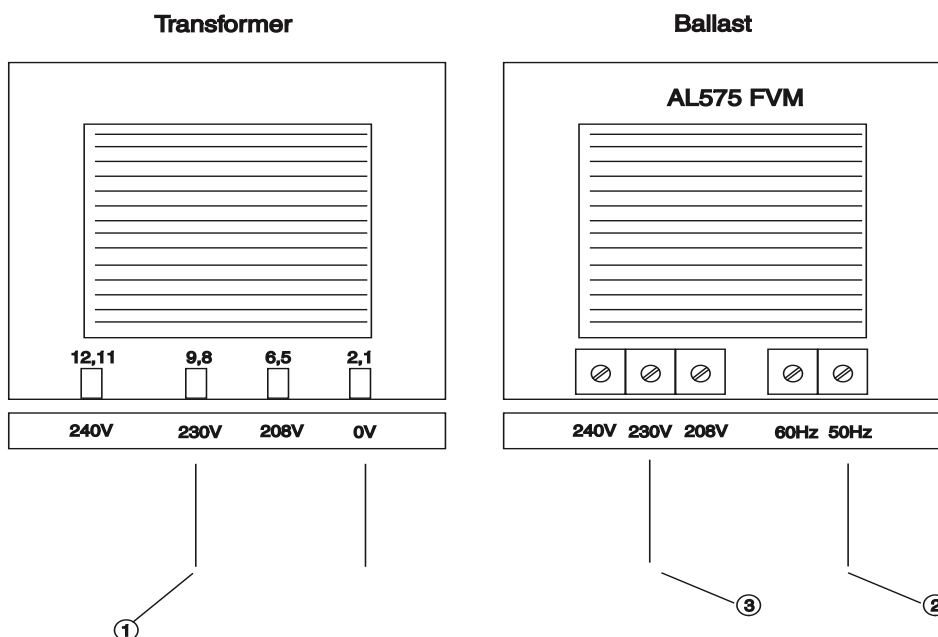

#### US-version Power supply settings: 120V/60Hz

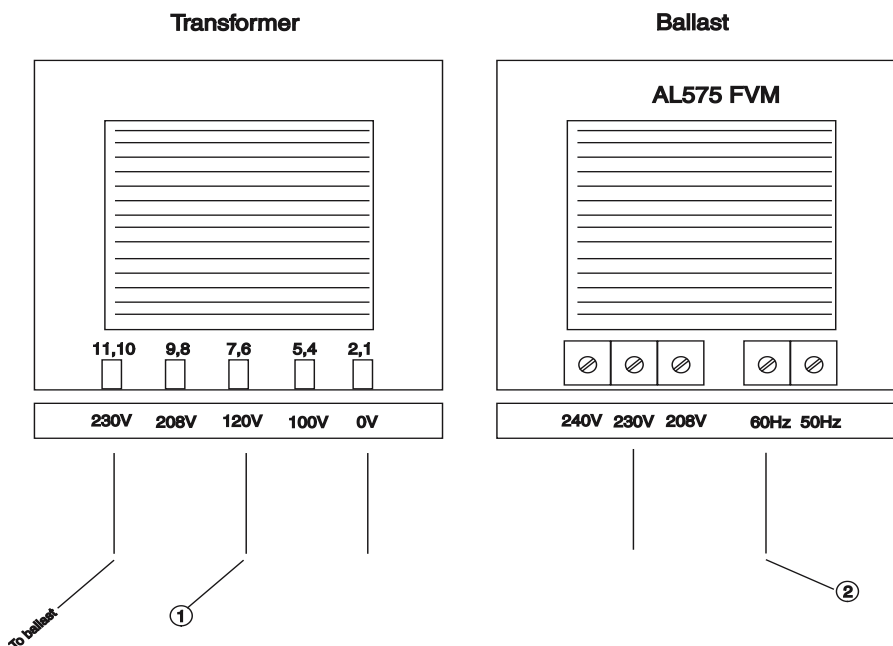

## 4.4 Rigging

**DANGER TO LIFE!**  
**Please consider the respective national norms during the installation!**  
**The installation must only be carried out by an authorized dealer!**

The installation of the projector has to be built and constructed in a way that it can hold 10 times the weight for 1 hour without any harming deformation.

The installation must always be secured with a secondary safety attachment, e.g. an appropriate catch net. This secondary safety attachment must be constructed in a way that no part of the installation can fall down if the main attachment fails.

When rigging, derigging or servicing the fixture staying in the area below the installation place, on bridges, under high working places and other endangered areas is forbidden.

The operator has to make sure that safety-relating and machine-technical installations are approved by an expert before taking into operation for the first time and after changes before taking into operation another time.

The operator has to make sure that safety-relating and machine-technical installations are approved by an expert after every four year in the course of an acceptance test.

The operator has to make sure that safety-relating and machine-technical installations are approved by a skilled person once a year.

The projector should be installed outside areas where persons may walk by or be seated.

**IMPORTANT! OVERHEAD RIGGING REQUIRES EXTENSIVE EXPERIENCE**, including (but not limited to) calculating working load limits, installation material being used, and periodic safety inspection of all installation material and the projector. If you lack these qualifications, do not attempt the installation yourself, but instead use a professional structural rigger. Improper installation can result in bodily injury and/or damage to property.

The projector has to be installed out of the reach of people.

If the projector shall be lowered from the ceiling or high joists, professional trussing systems have to be used. The projector must never be fixed swinging freely in the room.

**Caution:** Projectors may cause severe injuries when crashing down! If you have doubts concerning the safety of a possible installation, do NOT install the projector!

Before rigging make sure that the installation area can hold a minimum point load of 10 times the projector's weight.

**Danger of fire !**  
**When installing the device, make sure there is no highly inflammable material (decoration articles, etc.) in between a distance of min. 0,5 m.**

**CAUTION!**  
**Make sure that the device is fixed properly! Ensure that the structure (truss) to which you are attaching the fixtures is secure.**

The projector can be placed directly on the stage floor or rigged in any orientation on a truss without altering its operation characteristics .



### Overhead installation.

The mounting bracket provides 3 holes (a diameter of 13mm) and 2 quarter-circle slots.

To adjust the inclination-angle, loosen the 2 adjusting screws. Turn the projector to the desired angle and retighten the adjusting screws.

For overhead use, always install a safety rope that can hold at least 10 times the weight of the fixture. Pull the safety rope through the mounting bracket and over the trussing system etc.

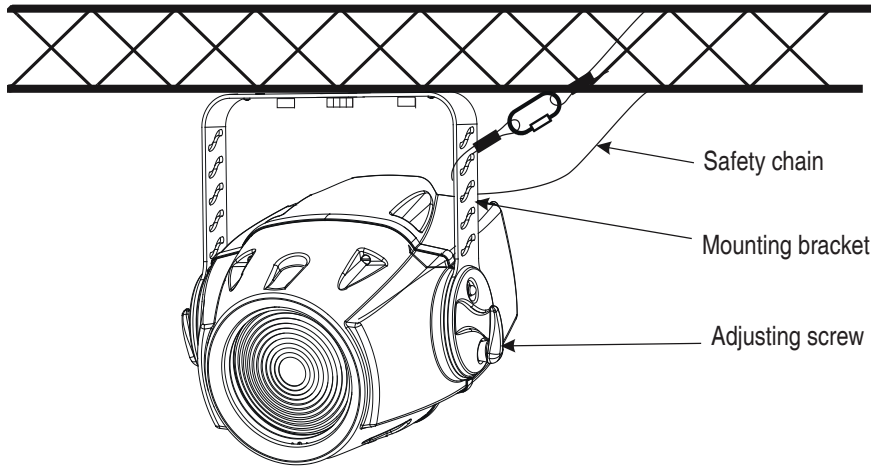

Mounting bracket (groundplan):

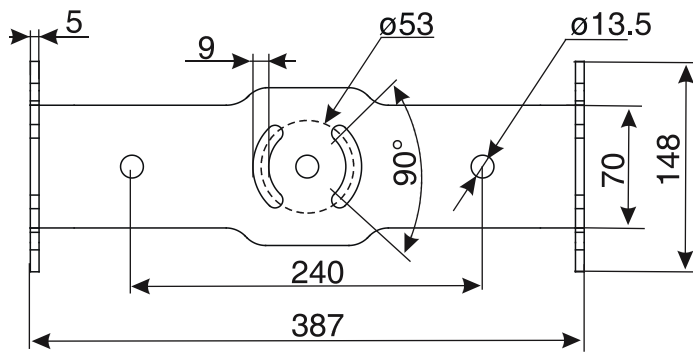

Measurements are in millimetres

### Floor installation.

The projector can stand directly on the floor by standing on the removable stand which is mounted with the nut to the projector mounting bracket.

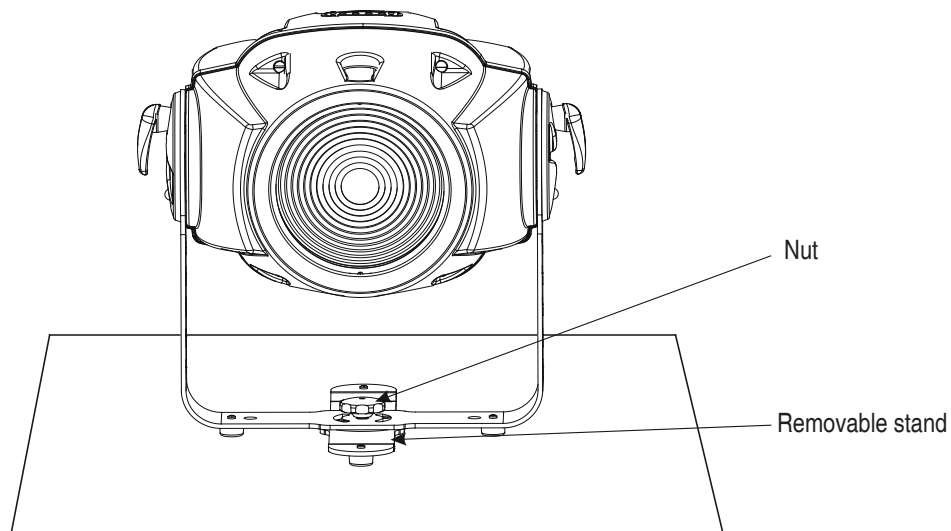

Removable stand:

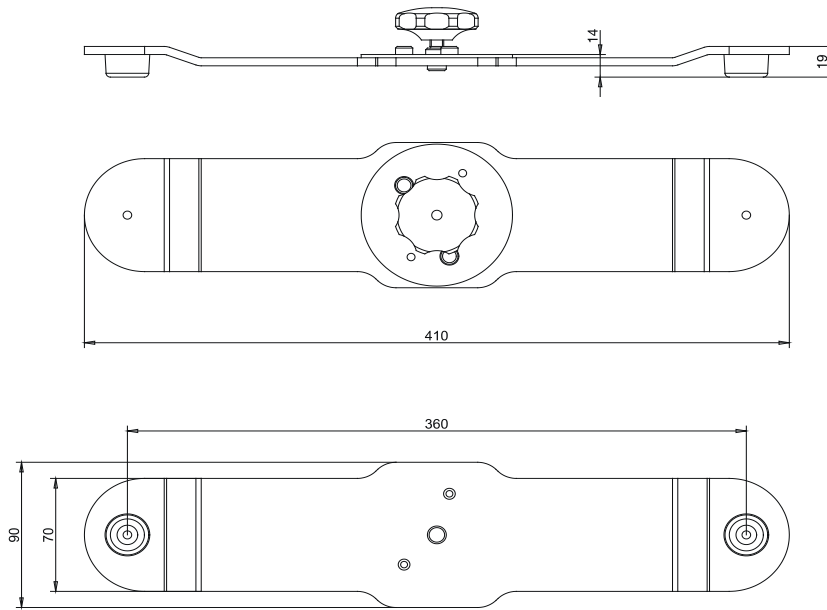

Measurements are  
in millimetres

**DANGER TO LIFE!**  
Before taking into operation for the first time, the installation has to be approved by an expert!

When installing fixtures side-by-side,  
avoid illuminating one fixture with another!

#### 4.5 Connection to the mains

**Verify the power supply settings before applying power!**

If you wish to change the power supply settings, see the chapter Appendix.

Connect the fixture to the mains with the enclosed power plug. If you need to install other power plug on the power cable, follow the identification table below.

The earth has to be connected!

**The occupation of the connection-cables is as follows:**

Cable (EU)	Cable (US)	Pin	International
Brown	Black	Live	L
Light blue	White	Neutral	N
Yellow/Green	Green	Earth	

**Do not connect the projector to a dimmer system!**

## 4.6 DMX 512 connection, master/slave connection

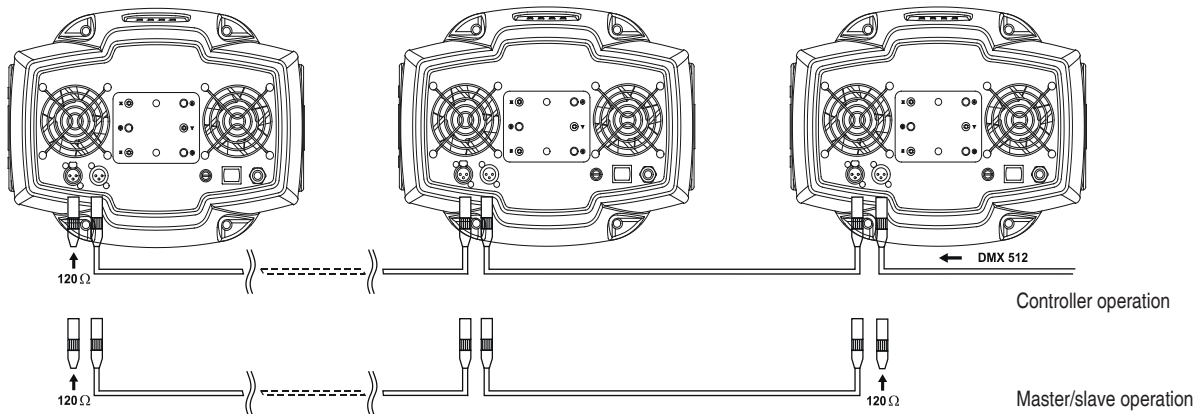

**The wires must not come into contact with each other, otherwise the fixtures will not work at all, or will not work properly.**

Only use a stereo shielded cable and 3-pin XLR-plugs and connectors in order to connect the controller with the fixture or one fixture with another.

### Occupation of the XLR-connection:

**DMX - output  
XLR mounting-socket:**

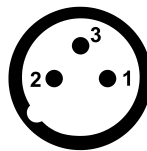

- 1 - Ground
- 2 - Signal (-)
- 3 - Signal (+)

**DMX-input  
XLR mounting-plug:**

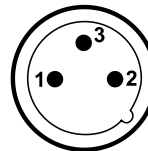

- 1 - Ground
- 2 - Signal (-)
- 3 - Signal (+)

### Building a serial DMX-chain:

If you are using the standard controllers, you can connect the DMX-output of the controller directly with the DMX-input of the first fixture in the DMX-chain. If you wish to connect DMX-controllers with other XLR-outputs, you need to use adapter-cables. Connect the DMX-output of the first fixture in the DMX-chain with the DMX-input of the next fixture. Always connect output with the input of the next fixture until all fixtures are connected.

**Caution:** At the last fixture, the DMX-cable has to be terminated with a terminator. Solder a 120 Ohm resistor between Signal (-) and Signal (+) into a 3-pin XLR-plug and plug it in the DMX-output of the last fixture.

### Building a master/slave-chain:

Connect the DMX-output of the master fixture in the data-chain with the DMX-input of the first slave. Always connect output with the input of the next slave until all slaves are connected (up to 9 fixtures).

**Caution:** It's necessary to insert the XLR termination plug (with 120 Ohm) into the input of the master fixture and into the output of the last slave fixture in the link in order to ensure proper transmission on the data link.

## 4.7 Installation of the barn-doors

You can install the barn-doors to better define the illuminated surface. The barn-doors are fixed with the 2 screws and may be turned in range 90°. Barn-doors are optional accessories.

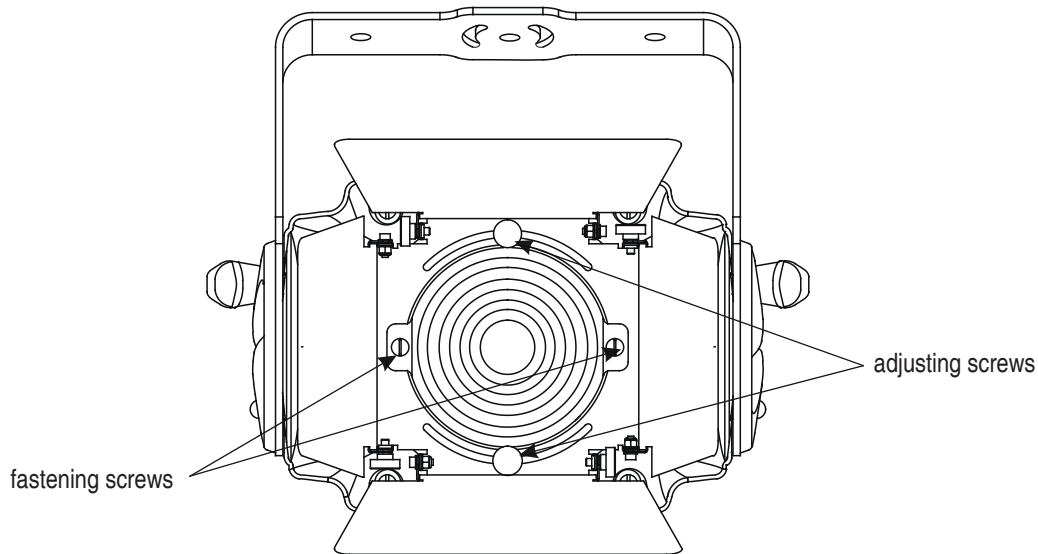

## 4.8 Changing the front lens

The ColorMix 575 AT can use the 2 types of the front lenses:

Fresnel lens - this lens is installed as a standard lens.

Wide-angle lens - optional accessories, it is not the standard part of delivery..

**Switch the fixture off before changing the lens. Be careful. Front lens is heavy!**

If you want to change the front lens, follow the instructions:

1. Remove the front cover by unlocking the 4 quarter-turn screws.
2. Remove the lens shielding by unscrewing the 8 screws.
3. Remove the fresnel lens by unscrewing the 2 screws
4. Remove the 4 distance rings.
5. Place the wide-angle lens and screw it with 2 screws.
6. Place back the lens shielding and screw it with the 8 fastening screws.
7. Fasten the front cover using the 4 quarter-turn fasteners.

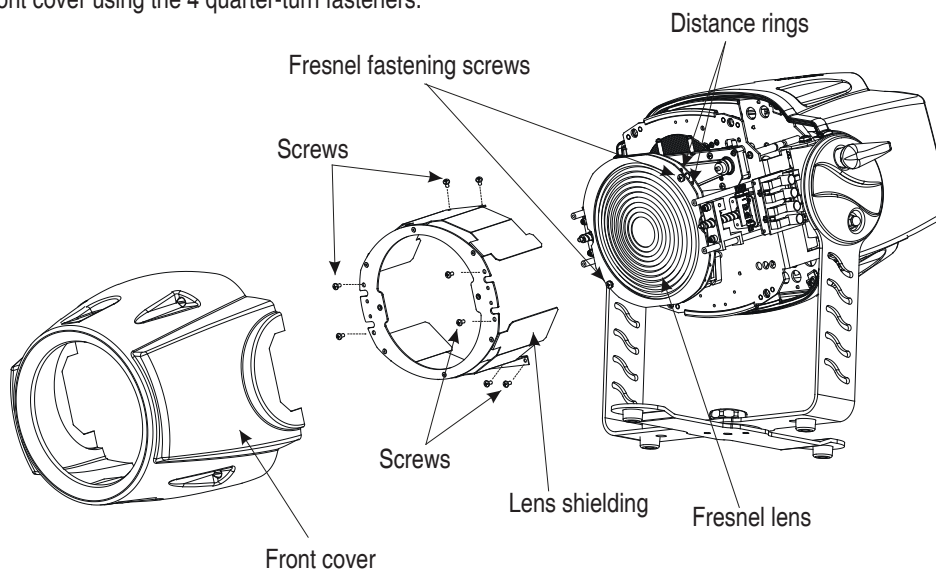

## 5. DMX Protocol

Mode 1 Channel	Mode 2 Channel	Value	Function	Type of control	
1	1	0-89	<b>Power/Special functions</b> Reserved <i>To activate following functions, stop in DMX value for at least 3 s and shutter must be closed at least 3 s. ("Shutter, Strobe" channel 12(10) must be at range:0-31 DMX).</i>	step	
		90-99	Blackout while colour wheel moving	step	
		100-109	Disabled blackout while colour wheel moving	step	
		110-129	No function	step	
				<i>To activate following functions, stop in DMX value for at least 3 s.</i>	
		130-139	Lamp On, reset	step	
		140-149	No function	step	
		150-159	Colour wheel + CMY+effect wheel reset	step	
		160-169	No function	step	
		170-179	Dimmer/Strobe reset	step	
		180-189	Zoom reset	step	
		190-199	Effect wheel+colour wheel reset	step	
		200-209	Total reset	step	
		210-229	No function	step	
230-239	Lamp Off	step			
240-255	Reserved	step			
2	2		<b>Colour wheel</b> <i>(disabled if CMY macro is active (channel 8 (7))</i> <b>Continual Positioning</b> <i>In range 0-129 DMX is possible fine colour positioning- set value on channel 3</i>		
		0	Open/white	proportional	
		16	Deep red	proportional	
		32	Blue	proportional	
		48	Green	proportional	
		64	Orange	proportional	
		80	CTF 3200K	proportional	
		96	CTF 5600K	proportional	
		112	UV filter	proportional	
		128-129	White	proportional	
			<b>Positioning</b>		
		130-138	Deep red	step	
		139-146	Blue	step	
		147-155	Green	step	
		156-163	Orange	step	
		164-172	CTF 3200K	step	
		173-180	CTF 5600K	step	
		181-189	UV filter	step	
		190-215	Forwards rainbow effect from fast to slow	proportional	
		216-217	No rotation	step	
		218-243	Backwards rainbow effect from slow to fast	proportional	
		244-249	Random colour selection by audio control (Set microphone sensitivity in menu "Personality")	step	
		250-255	Auto random colour selection from fast to slow	proportional	



Mode 1 Channel	Mode 2 Channel	Value	Function	Type of control
10	9	0-255	<b>Zoom</b> Coarse zoom from min. to max. beam angle	proportional
11		0-255	<b>Zoom fine</b> Fine movement of zoom	proportional
12	10	0-31 32-63 64-95 96-127 128-143 144-159 160-191 192-223 224-255	<b>Shutter, strobe</b> Shutter closed No function (shutter open) Strobe-effect from slow to fast No function (shutter open) Opening pulse in sequences from slow to fast Closing pulse in sequences from fast to slow No function (shutter open) Random strobe-effect from slow to fast No function (shutter open)	step step proportional step proportional proportional step proportional step
13	11	0-255	<b>Dimmer intensity</b> Coarse intensity from 0 to 100%	proportional
14		0-255	<b>Dimmer fine</b> Fine intensity	proportional

## 6. Controller mode

The fixtures are individually addressed on a data link and connected to the controller. The fixtures respond to the DMX signal from the controller.

### 6.1 DMX addressing

The control panel on the front side of the base allows you to assign the DMX fixture address, which is defined as the first channel from which the COLORMIX 575 AT will respond to the controller.

If you set, for example, the address to channel 5, the COLORMIX 575 AT will use the channel 5 to 15 for control.

Please, be sure that you don't have any overlapping channels in order to control each COLORMIX 575 AT correctly and independently from any other fixture on the DMX data link.

If two, three or more COLORMIX 575 AT are addressed similarly, they will work similarly.

For address setting, please refer to the instructions under "Addressing" (menu "**A001**").

#### Controlling:

After having addressed all COLORMIX 575 AT, you may now start operating these via your lighting controller.

**Note:** After switching on, the COLORMIX 575 AT will automatically detect whether DMX 512 data is received or not. If there is no data received at the DMX-input, the display will start to flash "**A001**" with actually set address.

This situation can occur if:

- the 3 PIN XLR plug (cable with DMX signal from controller) is not connected with the input of the COLORMIX 575 AT
- the controller is switched off or defective, the cable or connector is defective or the signal wires are swap in the input connector.

**Note:** It's necessary to insert the XLR termination plug (with 120 Ohm) to the last fixture in the link in order to ensure proper transmission on the DMX data link.

## 6.2 Remotely controllable functions

### Lamp

The COLORMIX 575 AT is to be operated with a MSR 575W/2 lamp.

A relay inside of the COLORMIX 575 AT allows you to switch on and off the lamp via the control panel on the top side of the projector or via your controller without affecting the rest of the lighting.

To switch On/Off the lamp, please refer to "Switching On/Off the lamp" (menu "**LAMP**").

**Note:** It is also important to note, that the discharge lamp is cold restrike types, that means, that they have to be cold before re-striking. For this reason, you have to wait 5 minutes (max. speed of fan must be adjusted) after having switched Off the lamp before you can switch it back On again. If you try to switch On the lamp within 5 minutes after having switched it Off, the COLORMIX 575 AT will store this information and automatically ignite the lamp when the 5 minutes period has expired. The message "**HEAT**" will appear on the control panel display of the COLORMIX 575 AT. If the ignition of the lamp is seven times unsuccessful, on the display will appear "**LA.Er**", meaning that the lamp could be damaged or even missed, or there could be a failure on the ignitor or ballast.

### Colour wheel

The COLORMIX 575 AT features a colour-wheel with 6 color positions - 3 dichroic colors, 2 correction filters 3200 K, 5600 K and UV filter + open. It is also possible to rotate the color-wheel continuously at different speeds, the so-called "Rainbow effect" is created.

### CMY colours mixing system

The CMY color mixing system is based on graduated cyan, magenta, and yellow color filters. A continuous range of colors may be achieved by varying the amount of each filter from 0 to 100%.

### Beam effects

The beam shaper allow you to widen and atten beam. Beam shaper rotates 180°.

Frost filter on the same wheel as beam shaper softens the beam.

### Zoom

Motorized zoom unit enables the beam to be zoomed between 10° and 26° beam angle with the standard Fresnel lens.

### Dimmer

Smooth 0 - 100 % dimming is provided by the special dimmer unit.

### Shutter/Strobe

Extremely fast shutter may also be used for strobe effect (max. 10 flashes per second).

### Fans

The COLORMIX 575 AT is cooled by the two axial fans. By the control board using the „**FAnS**” function you can choose 2 types of the fan speed operating modes.



## 7. Stand - alone mode

The fixtures on a data link are not connected to the controller but can execute pre-set programs which can be different for every fixture. To set the program to be played, see the "Stand-alone setting" ( menu "St.AL." ).

"Stand-alone operation" can be applied to the single fixture (the fixture may be set to the master /slave mode or controller mode ) or to multiple fixtures operating synchronously.

Synchronous operation of multiple fixtures requires that they must be connected on a data link and one of them is set as a master (master mode) and the rest as the slaves (slave mode). The slaves are assigned to SLA1-SLA9 and on the certain slave address can be connected only one fixture. To set the fixture as the master or slave , see the "Addressing" (menu "A001").

If the master fixture runs a reset or plays test(program) ,all slaves will execute these acts too.

You can't play or edit any programs on the slaves by their control panels if the master is switched on and connected to the master/slave chain.

The master fixture starts simultaneous program start in the other slave fixtures. All fixtures have a definite, synchronized starting point when playing back their programs. The number of running program is the same in all slaves and depends on the master's choice (menu "St.AL." ). Every fixture runs its program repeatedly , starting the program step No.1 when requested by the master .

For example:

If the slave fixture has a shorter program length, it will continuously repeat its program until the master fixture finishes its own program and restarts its program running (slave 1- prog.step 3 will not be finished).

If the slave fixture has a longer program length, it will restart at prog. step 1 before it completes all its prog.steps (slave 2 - prog.step 5 will not be played)- see the picture bellow.

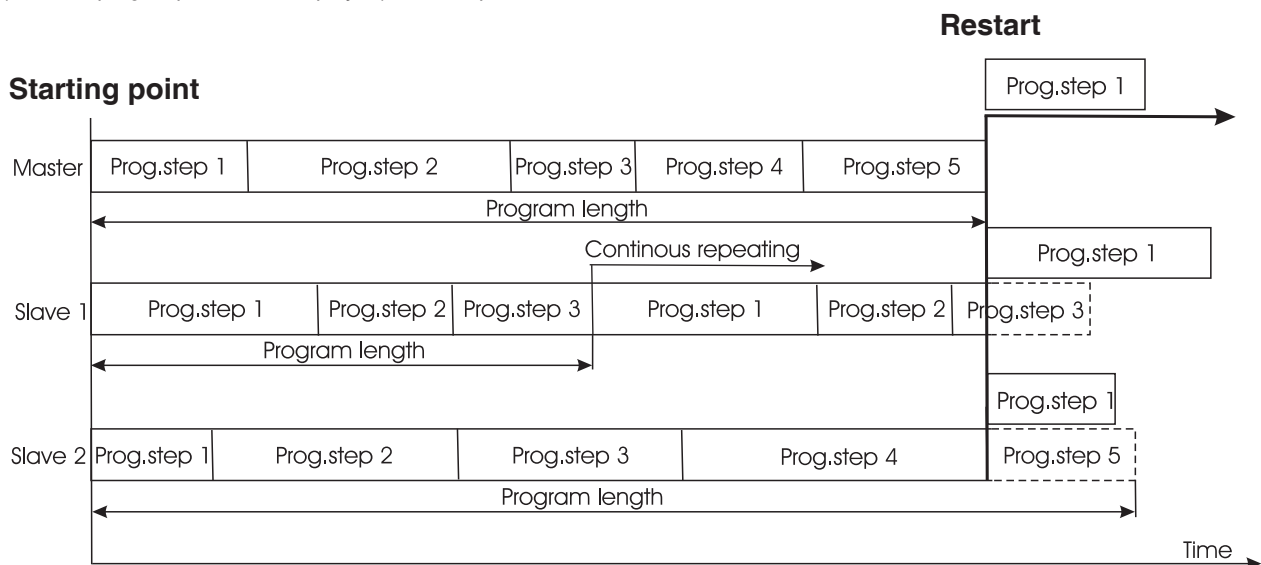

**Note:** Disconnect the fixtures from the DMX controller before master/slave operating ,otherwise data collisions can occur and the fixtures will not work properly!

It's necessary to insert the XLR termination plug (with 120 Ohm) into the input of the master fixture and into the output of the last slave fixture in the data link in order to ensure proper transmission on the data link.

From the master's control panel is possible to control any slave in a master/slave chain.

# 8.Control menu map

Default settings=**Bold print**

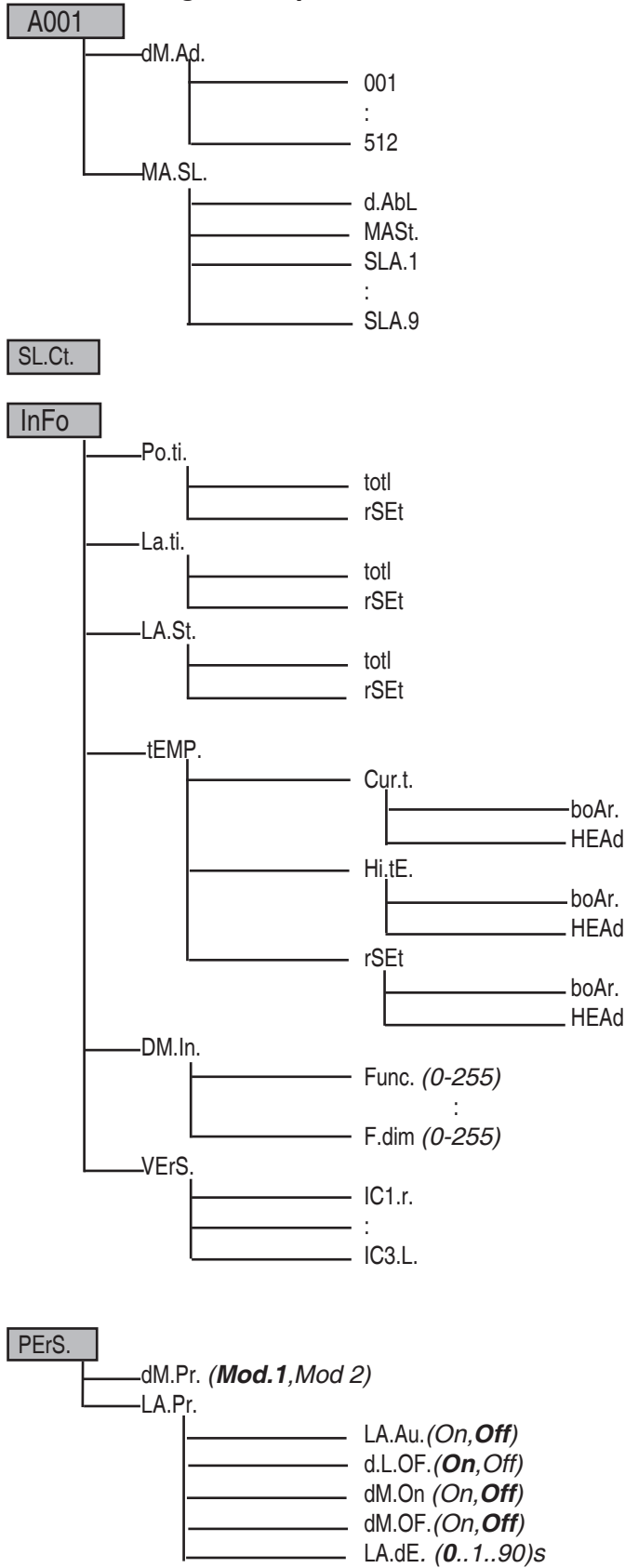

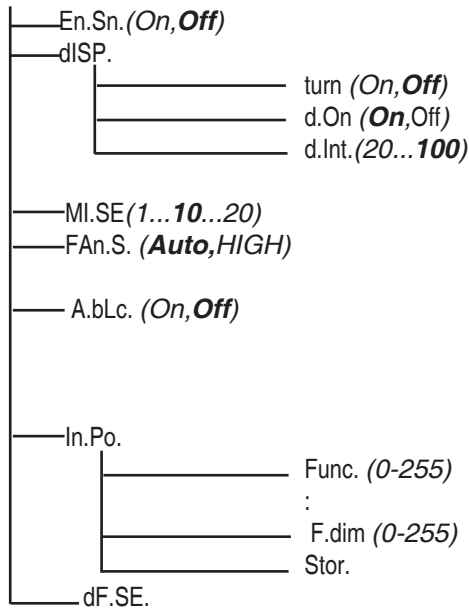

**LAMP** (*On, Off*)

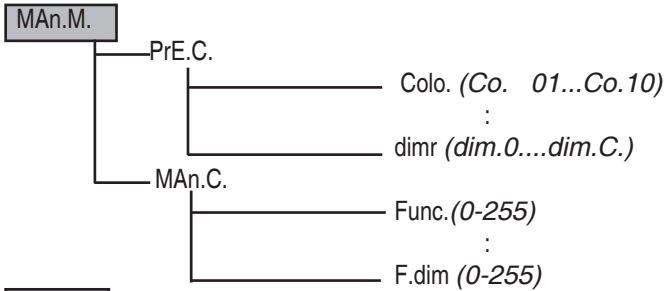

**tEst**

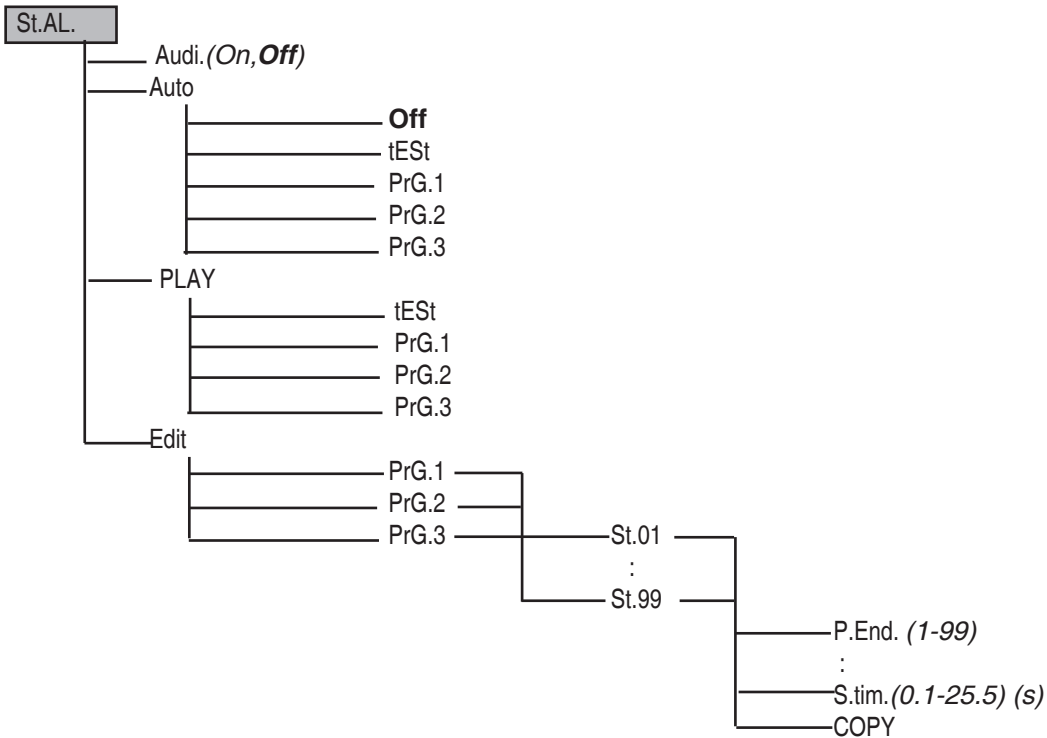

rESE.

SPEC.

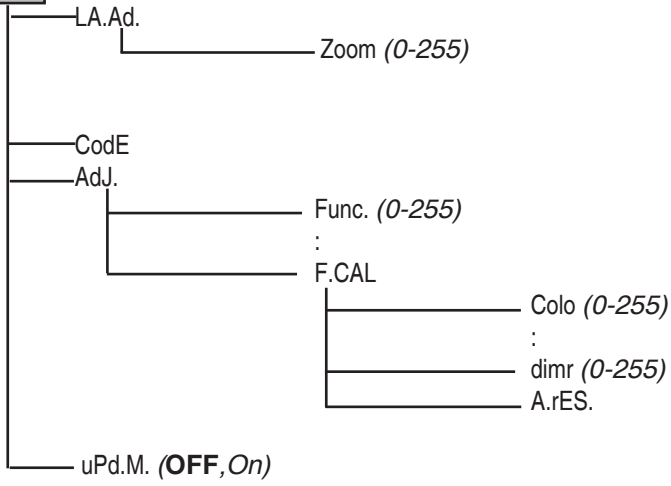

## 9. Functions of the control panel

The control panel situated on the front panel of the base offers several features. You can simply set the DMX address, read the number of the lamp or unit hours, switch On and Off the lamp, run test, make a reset and also use many functions for setting fixture behaviour.

### Control elements on the control board:

[MODE] button-leaves menu without saving changes.

[ENTER] button- enters menu, confirms adjusted values and leaves menu.

[UP] button and [DOWN] button- moves between menu items on the the same level, sets values.

After switching the fixture on, the display shows the initial DMX address:



Use [UP],[DOWN] to browse through the menu. To select a function or submenu, press [ENTER].

### 9.1 Fixture Address



Use this menu to set the DMX address of the fixture or set the fixture as a Master (Slave).

**dm.Ad.** --- **DMX addressing.** Select this submenu to set DMX start address.

**MA.SL.** --- **Master/slave addressing.** Select this submenu to set the fixture as a Master or Slave (Slave 1-Slave 9). Option "d.AbL" deactivates master/slave setting.

### 9.2 Slave control

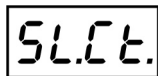

This function allows you to control the slaves from the master's control panel in a master/slave operation.

Select this function from the main menu and press [ENTER]. Browse the list of all connected slaves ("SL.C.1" - "SL.C.9") by pressing [UP] or [DOWN]. Select the desired slave and press [ENTER]-button. The matching slave control panel is available from the master control panel.

If no slave is connected to the master, messages "SL.C.1", "SL.C.2", "SL.C.3" ... "SL.C.9" still round repeat.

**Note:** This function is available from the master fixture only.

### 9.3 Fixture informations



Use this menu to read an useful information about the fixture.

**Po.ti.** --- **Power on time.** Select this submenu to read the number of operation hours.

**totL** --- The function shows the total number of the operation hours since the ColorMix 575 AT has been fabricated.

**rSEt** --- The function shows the number of the operation hours that the ColorMix 575 AT has been powered on since the counter was last reset. In order to reset this counter to 0 you have to hold [UP] and [DOWN] and press the [ENTER].

**La.ti.** --- **Lamp on time.** Select this submenu to read the number of the operation hours with the lamp on.

**totL** --- The function shows the total number of the operation hours with the lamp on since the ColorMix 575 AT has been fabricated.

**rSEt** --- The function shows the number of the operation hours with the lamp on that the ColorMix 575 AT has been powered on since the counter was last reset. In order to reset this counter to 0 you have to hold [UP] and [DOWN] and press the [ENTER].

**LA.St.** --- **Lamp strikes.** Select this submenu to read the total number of the lamp strikes.

**totL** --- The function shows the total number of the lamp strikes since the ColorMix 575 AT has been fabricated.

**rSEt** --- The function shows the number of the lamp strikes since the counter was last reset. In order to reset this counter to 0 you have to hold [UP] and [DOWN] and press the [ENTER].

**tEMP** --- **Fixture temperatures.** Select this submenu to read the fixture temperatures (°C). Please note that the outside temperature should not exceed 40° C.

**Cur.t. --- Current fixture temperatures.**

**boAr.** -Current temperature on the PCB in the fixture. Temperatures below 85°C are not critical. 82° C and more lead to the lamp being switched off and the fixture goes to "low power mode". Before switching the lamp on again (after 5 minutes), run a total fixture reset.

**HEAd** -Current temperature of the fixture head inside. Temperatures below 75°C are not critical. 70° C and more lead to the lamp being switched off and the fixture goes to "low power mode". Before switching the lamp on again (after 5 minutes), run a total fixture reset.

**Hi.tE. --- Maximum fixture temperatures.**

**boAr.** - The function shows the max.temperature on the PCB since the ColorMix 575 AT has been fabricated.

**HEAd** - The function shows the max.temperature of the fixture head inside since the ColorMix 575 AT has been fabricated.

**rSEt --- Maximum resetable temperatures.**

**boAr.** - The function shows the maximum temperature on the PCB since the counter was last reset. In order to reset the counter to 0 you have to hold [UP] and [DOWN] and press the [ENTER].

**HEAd** - The function shows the maximum temperature of the fixture head inside since the counter was last reset. In order to reset the counter to 0 you have to hold [UP] and [DOWN] and press the [ENTER].

**DM.In. --- Readout of DMX values.** Select this function to read DMX values (0-255) of each channel received by the fixture.

- Func.** a special function
- Macr.** CMY macros
- Colo.** a colour wheel
- Col.F.** a colour fine
- CYAN** cyan lamellas
- MAGE.** magenta lemellas
- YELL.** yellow lamelas

- C.SPd.** a CMY/dimmer speed
- EFFE.** an effect wheel
- Zoom** a zoom
- F.Zom.** a fine zoom
- Stro.** a strobe/shutter
- dimr** a dimmer
- F.dim.** a fine dimmer

**VErS. --- Software version.** Select this function to read the software version of processors:

- IC1.r.** --- Processor 1 on the right side board of the fixture
- IC2.r.** --- Processor 2 on the right side board of the fixture
- IC3.r.** --- Processor 3 on the right side board of the fixture
- IC1.L.** --- Processor 1 on the left side board of the fixture

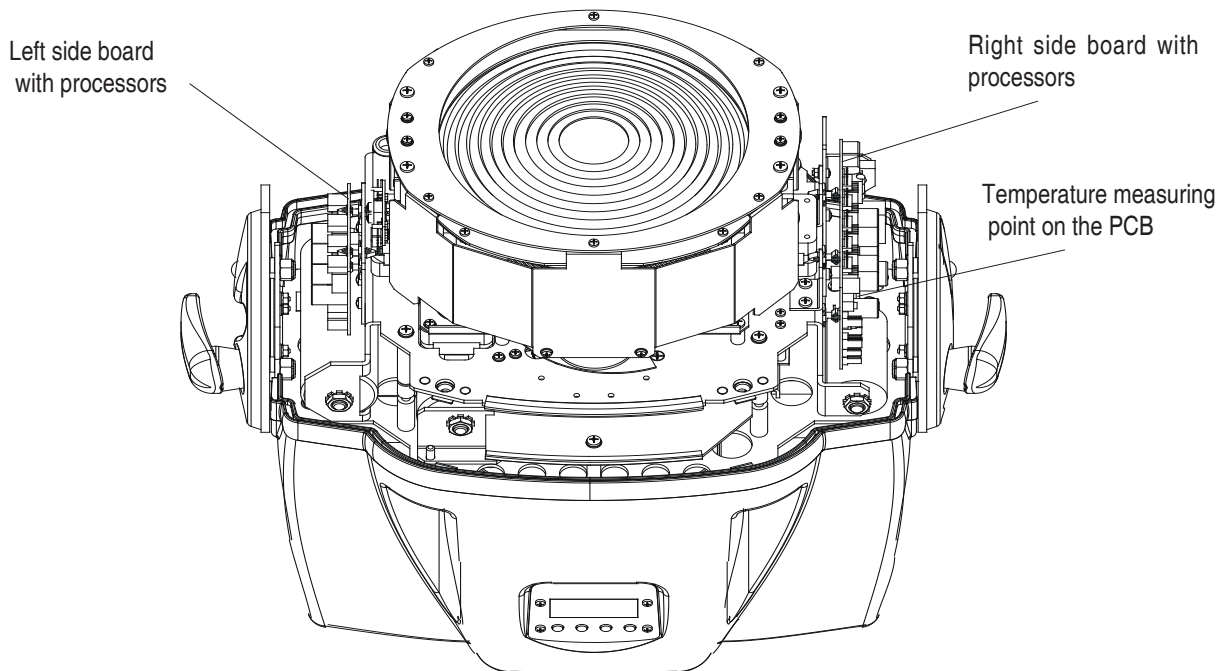

## 9.4 Personality



Use this menu to modify ColorMix 575 AT operating behavior.

**DM.Pr. --- DMX presetting.** Select this function to set desired effects assigning to the channels. Please refer to the chapter "DMX protocol" for detail description.

**LA.Pr. --- Lamp presetting.** Select this menu to change the lamp "behaviour".

**LA.Au. ---** Select this function to turn the lamp on automatically after switching the fixture on.

**d.L.OF. ---** Select this function to switch off the lamp via DMX.

**dM.On ---** This function allows you to strike the lamp automatically after 26 seconds if DMX signal is present on the data link. If the ignition is unsuccessful (e.g. lamp is too hot), the fixture will try to ignite the lamp after next 26 s. This process will repeat until the lamp lights.

**dM.OF. ---** This function allows you to switch Off the lamp automatically after 2 minutes if DMX signal is missing on the data link.

**LA.dE. ---** Lamp ignition delay. This function allows you to set the time delay (0-90s) before the lamp will be ignited. This setting will not affect starting the lamp direct from the control panel (menu "Lamp On/Off").

**En.Sn. --- Switching on/of the lamp light sensor.** Select this function to switch the lamp light sensor on or off. The option "On" is for the standard operation.

Important: The option "Off" is for "emergency operation" only if the lamp light sensor is defective and you will wait for a service intervention! If the lamp light sensor is switched off and at switching the lamp on the electronics will still try to ignite the lamp until it shines (even when the lamp is damaged or absent), on this account some electronics parts could be damaged!

**Di.SP. --- Display adjusting.** This function allows you to change the display settings.

**turn ---** Select this function to turn the display by 180°.

**d.On ---** This function allows you to keep the display on or to turn off automatically 2 minutes after last pressing any button on the control panel.

**d.Int. ---** Select this function to adjust the display intensity (20-min., 100-max.).

**Mi.SE. --- Microphone sensitivity.** Select this function to adjust the microphone sensitivity from 1 (maximum) to 20 (minimum). If the sensitivity is correctly adjusted, the upper segment of the first digit blinks in the bass beat.

Examples:



underexited



right level



overexited

(upper segment blinks via the bass rhythm)

**Fan.S. --- Fan speed operating modes.** By using this function you can choose 2 types of the fan speed operating modes.

**Auto ---** The fans automatically raise their speed in order to control inside temperature of the head, if the temperature inside increases about certain level (the low fan speed reduces the cooling of the lighting).

This cycle can repeat several times until the temperature inside is on a suitable level.

**HIGH ---** The cooling fans work on max. speed (max. cooling). This mode we recommend for high ambient temperature (30 °C and more).

**A.blc. --- Automatic blackout.** Use this function if you wish to close the light output when the colour wheel moving.

**In.Po. --- Init effect positions.** Select this function to adjust all effects to the desired initial positions. After switching the fixture on (if DMX is not connected), all effects will move to initial positions. Use the [UP] and [DOWN] buttons to select desired channel and press [ENTER]. Set the effect to the desired position using [UP] and [DOWN] buttons and confirm by pressing [ENTER]. After having adjusted required effects, select "Stor." to save all initial values to the memory.

**dF.SE. --- Default Settings.** Select this option to reset all fixture personalities to the default values.

## 9.5 Lamp On/Off



Use this option in order to switch on/off the lamp. It is also important to note, that the lamp is cold restrike type, that means, that it has to be cold before striking.

## 9.6 Manual mode



Select this menu to call up presetted positions of channel effects or direct control channel effects.

**PrE.C. --- Presetted effect control.**Select this menu to call up presetted positions of the channel effects.

**Man.C. --- Manual effect control.**Select this menu to control effects by control buttons on the control board.

**Func.** a special function  
**Macr.** CMY macros  
**Colo.** a colour wheel  
**Col.F.** a colour fine  
**CYAN** cyan lamellas  
**MAGE.** magenta lemellas  
**YELL.** yellow lamellas

**C.SPd.** a CMY/dimmer speed  
**EFFE.** an effect wheel  
**Zoom** a zoom  
**F.Zom.** a fine zoom  
**Stro.** a strobe/shutter  
**dimr** a dimmer  
**F.dim.** a fine dimmer

## 9.7 Test sequences



Use this menu to to run a special demo-test sequences without an external controller, which will show you some possibilities of using ColorMix 575 AT.

## 9.8 Stand-alone setting



Use this menu to set options for stand-alone mode as a selection of the playing program,programming and modifying current programs.

**Audi --- Music trigger.**Select this function to enable the sound control of the running programs via the built-in microphone.

**Auto --- Presetting playback.**This function allows you to select the program which will be played in the stand-alone mode after switching the fixture on.Selected program will be played continuously in a loop.

**d.Abl** --- The option disables "Auto" function.

**tESt** --- The option will start built-in test program.

**PrG. 1** --- The option will start created program No.1

**PrG. 2** --- The option will start created program No. 2

**PrG. 3** --- The option will start created program No. 3

**Note:**If the fixture operates in the controller mode ( DMX controller is connected) and any program from this menu is selected ,in this case the fixture will not respond to the DMX controller after switching on and will play selected program.

**PLAY --- Playing program.**Select this menu to run a bilt-in program or the 3 freely-programmable programs in a loop.

**tESt** --- The option starts built-in test program.

**PrG.1** --- The option starts created program No. 1

**PrG.2** --- The option starts created program No. 2

**PrG. 2** --- The option starts created program No. 3

Select the program you wish and press [ENTER].The selected program starts running.By Pressing [ENTER] again is possible to pause the program running.

**Edit --- Editing program.**Select this menu to edit or create the program.The ColorMix 575 AT has one built-in program and the 3 free programs,each up to 99 steps.Each program step has a step time.Step time-the time,during which effects last in the current step. If the fixture is set as a master ,then you may edit any program in the slaves.You can't edit programs on the slave fixtures from their control panels if the master fixture is switched on and connected to the slaves (editing is possible by the master control panel only).

Procedure:

1. Press [UP] or [DOWN] to select the program you want to edit ("PrG.1" - "PrG.3") and press [ENTER].



2. Press [UP] or [DOWN] to select the desired fixture ("MASt." - "SLA.9") and press [ENTER]-button.
3. Press [UP] or [DOWN] to select the desired program step ("St.01" - "St.99") and press [ENTER]-button.
4. Press [UP] or [DOWN] to select the desired item and press [ENTER]-button. Now you can edit by [UP] or [DOWN] buttons the DMX value (0-255) for selected item:

**P.End.** - a total number of the program steps (value 1-99). **This value you must set before start programming** (e.g. if you want to create program with the 10 steps, set P.End=10).

**Colo.** a colour wheel

**Col.F.** a colour fine

**CYAN** cyan lamellas

**MAGE.** magenta lamellas

**YELL.** yellow lamellas

**Macr.** CMY macros

**S.tim.** a step time, value 0,1-25,5 seconds

**COPY.-** copying the current prog. step to the next prog. step. If the last prog. step is copied to the

next prog. step, parameter "**P.End**" is increased about one by itself (except step 99).

5. Press [ENTER]-button to confirm adjusted value.

6. Press [MODE]-button, select next prog. step and repeat this procedure (steps 4 - 6).

**C.SPd.** a CMY/dimmer speed

**EFFE.** an effect wheel

**Zoom** a zoom

**Stro.** a strobe/shutter

**dimr** a dimmer

## 9.9 Reset functions



This option enables the ColorMix 757 AT to index all effects (functions) and return to their standard positions.

## 9.10 Special functions



Use this menu for special services like adjusting lamp or adjusting effects.

**LA.Ad. --- Lamp adjustment.** This function can be used when you make the fine adjustment of the lamp. If you select this function, all effects will be canceled, shutter will be opened and the dimmer intensity will be set onto 100%. By using the option "**Zoom**" you can set the light level on the at surface (wall) and perform the fine lamp adjustment.

**CodE --- Code.** This function contains identification hexadecimal code (0000-FFFF) for the fixture, which is used for the master/slave operation.

**Adj. --- Effect adjustment.** By this function you can calibrate and adjust the effects to their standard/right positions. Disconnect the DMX controller from the fixture and select "**Adj.**" menu. The display shows step by step effects by which you can adjust the fixture to the required position before the function calibration (DMX controller must be disconnected). When the positioning is finished, select "**F.CAL.**" and press [ENTER]:

### 1. Calibration via the control board

Disconnect DMX controller from the fixture. Press [ENTER] and use [UP] and [DOWN] in order to display the following items: "**Colo**, **CYAn**, **MAGE**, **YELL**, **EFFE**, **Zoom**, **dimr**" for very smooth function calibration. Select one of them, press [ENTER] and use the [UP] and [DOWN] in order to adjust their right value from 0 to 255. Then press [ENTER] to confirm or [MODE] to cancel and return to the menu. This can be repeated for each calibration parameter if it is required. When the calibration is finished, it is necessary to use the "**A.rES**" function in order to write the calibration values to the memory (EPROM) and to make a reset in order to check the newly adjusted positions of the colour, gobo wheels and dimmer. When the reset of the fixture is finished, the display will show the "**F.CAL**" message. Press [ENTER] to repeat the calibration or [MODE] to return to the "**Adj.**" menu.

### 2. Calibration via the external controller

Connect the DMX controller to the fixture, press [ENTER] and the [UP] and [DOWN] buttons in order to display the following items: "**Colo**, **CYAn**, **MAGE**, **YELL**, **EFFE**, **Zoom**, **dimr**". Select one of them and press [ENTER].

Now you can calibrate this effect by your controller. The DMX calibration protocol is described in the table mentioned below.

DMX calibration protocols:

Effect	Mode 1	Mode 2
"Colo."- Colour wheel	channel 15	channel 12
"CYAn"- Cyan	channel 16	channel 13
"MAGE."-Magenta	channel 17	channel 14
"YELL."- Yellow	channel 18	channel 15
"EFFE." - Effect wheel	channel 19	channel 16
"Zoom"-Zoom	channel 20	channel 17
"dimr"- Dimmer	channel 21	channel 18

After having calibrated required effects, press [ENTER] to confirm (or [MODE] to cancel and return to the menu without reset by the "A.rES." function) and use the "A.rES." function in order to write the calibration values to the memory (EEPROM) and to make a reset in order to check the new adjusted positions of the colour, gobo and effect wheels .

**Upd.M. ---Updating mode.** Using this function you can update software in the fixture via PC and serial link.

The following are required in order to update software:

- PC running Windows 95/98/2000/XP or Linux
- DMX Software Uploader
- Flash cable RS232/DMX (No.13050624)

**Note1:** Software update should execute a qualified person. If you lack qualification, do not attempt the update yourself and ask for help your ROBE distributor.

**Note 2:** DMX address, programs 1-3 and all functions in menu Personality "PErS." will be set to their default values

#### **To update software in the fixture:**

##### **1. Installation of DMX Software Uploader:**

1. DMX Software Uploader program is available from the ROBE web site at [WWW.robe.cz](http://WWW.robe.cz).
2. Make a new directory ( e.g. Robe\_Uploader) on your hard disk and download the software to it.
3. Unpack the program from the archive. Program file has name: DSU\_name of corresponding fixture\_SoftwareID. If the Robe fixture is produced in magnetic and electronic ballast version, the name of the DMX Software Uploader is the same for both versions. SoftwareID describes the versions of fixture software included in DMX Software Uploader. Higher number means later software versions.

##### **2. Fixture software updating:**

1. Determine which of your COM port is available on your PC and connect it with to the DMX input of the fixture using the Flash cable. Do not extend this cable! Disconnect the fixture from the other fixtures in DMX chain! Turn on the computer and the fixture. Make sure that the lamp is switched off.
2. Switch the fixture to the update mode by selecting the option Updating mode in menu Special Functions on the fixture control panel: SPEC-->UPd-->YES. (From this option you cannot return back to the main menu. If you do not want to continue in software update, you have to switch off and on the fixture to leave this option!)
3. It is recommended that you exit all programs before running the Software Uploader.
4. Start the Software Uploader program. Select desired COM and then click Connect button. If the connection is OK, click Start Uploading button to start uploading. It will take several minutes to perform software update. If the option "Incremental Update" isn't checked all processors will be updated (including processors with the same software version).

If you wish to update only later versions of processors, enable the Incremental Update check box.

Avoid interrupting the process. Update status is being displayed in the list window.

When the update is finished, the line with the text "The fixture is successfully updated" will appear in this window and the fixture will reset with the new software.

Note: In the case of interruption of the upload process (e.g. power cut), the fixture remains in the update mode and you have to repeat the software update again.

For example: The fixture was switched off before finishing software upload. After switching the fixture on again, the fixture is still in the update mode and the display is dark. Restart the Software Uploader program and repeat software update from your PC.

## **10. Low power mode**

This mode omits fixture reset after switching the fixture on and lowers motor powers of the fixture. To enter "Power down mode", press and hold [UP] and [DOWN] and at the same time switch on the Power switch. The following message appears on the display: "P.d.Mo." Press [ENTER] to activate "Low power mode" without fixture reset. Now you can set features and behaviour of the fixture by using "A001" menu and "Pers." menu. If you want to go "normal operation mode", execute fixture reset.

**Note:** All motors in "Low power mode" are deactivated and switching the lamp on from the control panel is blocked.

## **11. Error and information messages**

### **HEAt**

This message appears if you try to switch on the lamp within 5 minutes after having switched it off (the lamp is too hot). The message will appear on the display if the lamp doesn't ignite within 28 seconds. The fixture will store this information and automatically ignite the lamp when the 5 minutes period has expired.

**Caution:** The message is disabled if the lamp light sensor (function "En.Sn.") is switched Off (only if the lamp was turned Off and On within 5 minutes, the message "HEAt" will appear).

### **LA.Er.**

The ignition of the lamp is seven times unsuccessful (the HEAt message appeared six times before), and the display shows "LA.Er", meaning that the lamp could be damaged or even missed, the fixture is overheating (this can occur if the ambient temperature is 40° C or more) or there could be a failure on the ignitor or ballast.

Please place or replace the lamp, check the ambient temperature or contact your dealer if the situation was not caused by the lamp.

**Caution:** The message is disabled if the lamp light sensor (function "En.Sn.") is switched Off.

### **M.b.Er.**

This message informs you that the main PCB does not communicate correctly with the control panel.

### **F.t.Er.**

The message informs you that the fixture was overheating (occured if the ambient temperature is 40° C or more) and that the relay switched off the lamp. This message will appear on the display until the temperature will be on a suitable level, then the display will show the "HEAt" message meaning the lamp is too hot.

### **Co.Er. (color-wheel error)**

This message will appear after the reset of the fixture if the magnetic-indexing circuit malfunctions (sensor failed or magnet missing) or the stepping-motor is defective (or its driver circuit on the PCB). The color-wheel is not located in the default position after the reset.

### **EF.Er. (Effect-wheel error)**

This message will appear after the reset of the fixture if the magnetic-indexing circuit malfunctions (sensor failed or magnet missing) or the stepping-motor is defective (or its driver circuit on the PCB). The beam effect-wheel is not located in the default position after the reset.

### **Zo.Er. (Zoom error)**

This message will appear after the reset of the fixture and if the magnetic-indexing circuit malfunctions (sensor failed or magnet missing) or the stepping-motor is defective (or its driver circuit on the PCB). The zoom is not located in the default position after the reset.

### **Sn.Er.**

This message appears if the lamp lighting sensor is failed. Please, contact your dealer.

**Caution:** The message is disabled if the lamp light sensor (function "En.Sn.") is switched Off.

### **Po.Er.**

This message will appear if the fixture was shortly disconnect from the main.

### **MA.Er. (Master error)**

The message informs you that the fixture was addressed as a master and DMX signal is connected to its DMX input. Disconnect the DMX controller from fixture's input and address the fixture as the master again.

### **Fr.Er.**

This message will appear if the frequency of the main is not standard 50 or 60 Hz. This message can appear as a result of the interference during the lamp starting (if the lamp or igniter is old) or as a result of the interference by neighbouring devices. **In these cases the message does not affect the fixture operating!**

### **t.M.Er. (Temperature measuring error)**

The message informs you that the communication between the head temperature measuring sensor and its IC on the PCB was cut off and the lamp was automatically switched off.

## **12. Technical specifications**

### **Power supply:**

EU-model	Voltage.....208/230/240V AC, 50/60 Hz ~
	Fuse.....T 6.3 A@230V
US-model	Voltage.....100/120/208/230 V AC, 50/60Hz ~
	Fuse.....T 10 A@120V
	Power consumption....730 VA

### **Lamp**

Philips MSR 575W/2 GX-9.5

### **Colours**

CMY - colours mixing system  
4 dichroic-filters, 3 correction filters (5600K, 3200K, UV) plus white  
Colour wheel with variable rotation speed

### **Beam effects**

Beam shaper  
Frost filter

### **Strobe**

Strobe effect with variable speed

### **Dimmer**

Smooth dimmer from 0 - 100 %

### **Motors**

7 high quality stepping-motors controlled by microprocessors

## Optical System

- High luminous-efficiency parabolic reflector
- Standard Fresnel lens of diameter 200 mm
- Motorized zoom 10°-26° with the standard Fresnel lens
- 81° Beam angle with the optional wide-angle lens

## Beampath

### Fresnel lens

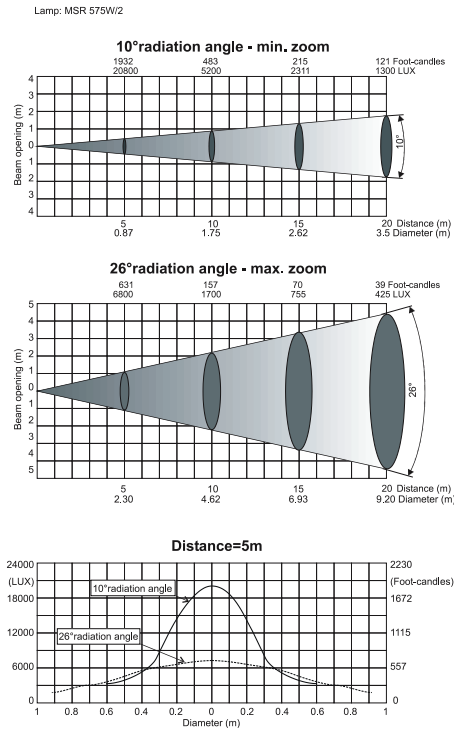

## Fans

Three axial fans

## Electronics

- Built-in microphone for music trigger
- Master/slave operation
- 3 freely programmable programs (99 steps each)
- Digital serial input DMX-512
- 2 DMX channel-presettings (11 or 14 channels)

## Rigging

- Stands directly on the floor with removable stand
- Mounts horizontally or vertically with mounting bracket
- Vertical head adjusting range: 135°

## Temperatures

- Maximum ambient temperature  $t_a$ : 40° C
- Maximum housing temperature  $t_b$  (steady state): 80° C

## Minimum distances

- Min.distance from flammable surfaces: 1.0 m
- Min.distance to lighted object: 1.5m

## Weight (net)

- EU-version:22 kg
- US-version:26 kg

### Dimensions (mm):

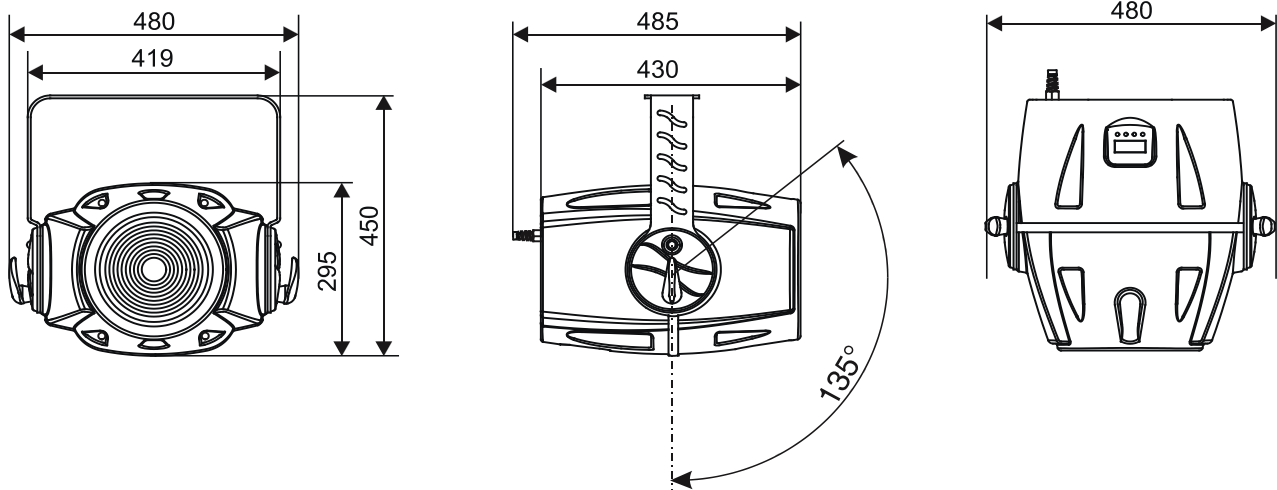

### Optional accessories:

- Barn-doors.....No. 99011064
- Wide-angle lens.....No. 99011082
- Flash cable RS232/DMX.....No.13050624

## 13. Maintenance and cleaning

The operator has to make sure that safety-relating and machine-technical installations are inspected by an expert after every four years in the course of an acceptance test.

The operator has to make sure that safety-relating and machine-technical installations are inspected by a skilled person once a year.

The following points have to be considered during the inspection:

- 1) All screws used for installing the devices or parts of the device have to be tightly connected and must not be corroded.
- 2) There must not be any deformations on housings, fixations and installation spots (ceiling, suspension, trussing).
- 3) Mechanically moved parts like axles, eyes and others must not show any traces of wearing (e.g. material abrading or damages) and must not rotate with unbalances.
- 4) The electric power supply cables must not show any damages, material fatigue (e.g. porous cables) or sediments. Further instructions depending on the installation spot and usage have to be adhered by a skilled installer and any safety problems have to be removed.

**DANGER TO LIFE !**  
**Disconnect from the mains before starting**  
**maintenance operation!**

It is essential that the fixture is kept clean and that dust, dirt and smoke-uid residues must not build up on or within the fixture. Otherwise, the fixture's light-output will be significantly reduced. Regular cleaning will not only ensure the maximum light-output, but will also allow the fixture to function reliably throughout its life.

Please use a moist, lint-free cloth. Never use alcohol or solvents!

The front fresnel lens will require weekly cleaning as smoke-uid tends to building up residues, reducing the light-output very quickly. The cooling fans should be cleaned monthly.

The interior of the fixture should be cleaned at least annually using a vacuum-cleaner or an air-jet.

The dichroic colour-filters should be cleaned monthly.

There are no serviceable parts inside the device except for the lamp and the fuse. Maintenance and service operations are only to be carried out by authorized dealers.

Please refer to the instructions under "Fitting/Exchanging the lamp".

## **Replacing the fuse**

If the lamp burns out, the fine-wire fuse of the device might fuse, too. Only replace the fuse by a fuse of same type and rating.

### **Before replacing the fuse, unplug mains lead.**

#### **Procedure:**

**Step 1:** Unscrew the fuseholder on the rear panel of the fixture with a fitting screwdriver from the housing (anti-clockwise).

**Step 2:** Remove the old fuse from the fuseholder.

**Step 3:** Install the new fuse in the fuseholder.

**Step 4:** Replace the fuseholder in the housing and fix it.

Should you need any spare parts, please use genuine parts.

If the power supply cable of this device will be damaged (cable firmly connected with the device), it has to be replaced by authorized distributor only in order to avoid hazards.

