

Color Mix **240**^{AT}

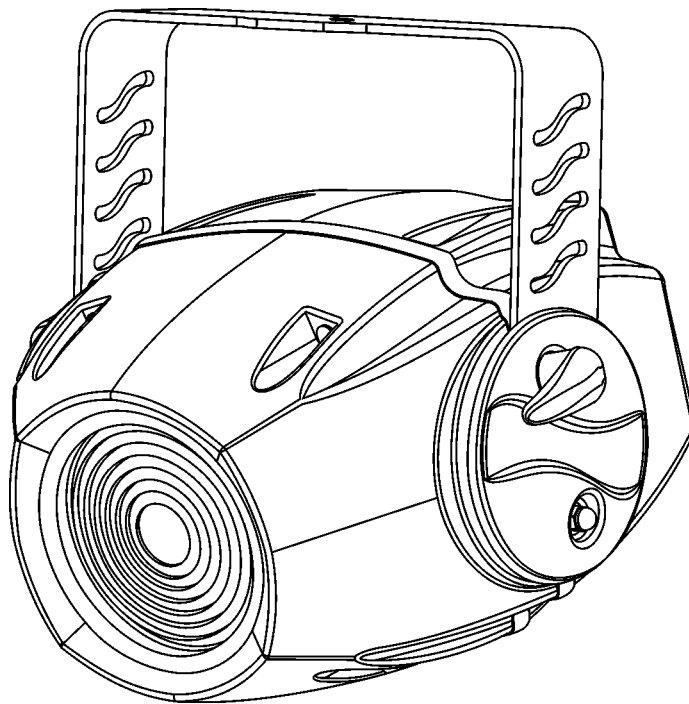

at **SERIES**

USER MANUAL

Color Mix 240^{AT}

Table of contents

1. Safety instructions	4
2. Operating determinations	4
3. Description of the device	5
4. Installation	6
4.1 Fitting/Exchanging the lamp	6
4.2 Lamp adjustment	6
4.3 Installation of the barn-doors	6
4.4 Manually adjustment of the beam angle	7
4.5 Rigging	7
4.6 Connection to the mains	8
4.7 DMX- 512 connection, master/slave connection	9
5. DMX Protocol - 8 bit	10
6. Controller mode	11
6.1 DMX addressing	11
6.2 Remotely controllable functions	11
7. Stand - alone mode	11
8. Functions of the control panel	12
8.1 Addressing	12
8.2 Slave control	13
8.3 Fixture informations	13
8.4 Personality options	15
8.5 Switching On/Off the lamp	18
8.6 Test sequences	18
8.7 Stand-alone setting	18
8.8 Reset function	20
8.9 Special functions	20
9. Error and information messages	21
10. Technical specifications	21
11. Maintenance and cleaning	23
12. Appendix 1 - Menu map	24
13. Appendix 2 - Changing the power supply settings	26

CAUTION ! *Keep this device away from rain and moisture! Unplug mains lead before opening the housing!*

FOR YOUR OWN SAFETY, PLEASE READ THIS USER MANUAL CAREFULLY BEFORE YOU INITIAL START - UP!

1. Safety instructions

CAUTION ! *Be careful with your operations. With a dangerous voltage you can suffer a dangerous electric shock when touching the wires*

This device has left our premises in absolutely perfect condition. In order to maintain this condition and to ensure a safe operation, it is absolutely necessary for the user to follow the safety instructions and warning notes written in this manual.

Important:

Damages caused by the disregard of this user manual are not subject to warranty. The dealer will not accept liability for any resulting defects or problems.

If the device has been exposed to drastic temperature fluctuation (e.g. after transportation), do not switch it on immediately. The arising condensation water might damage your device. Leave the device switched off until it has reached room temperature.

This device falls under protection-class I. The power plug must only be plugged into a protection class I outlet. Never let the power-cord come into contact with other cables! Handle the power-cord and all connections with the mains with particular caution!

Make sure that the available voltage is not higher than stated on the rear panel.

Make sure that the power-cord is never crimped or damaged by sharp edges. Check the device and the power-cord from time to time.

Always disconnect from the mains, when the device is not in use or before cleaning it. Only handle the power-cord by the plug. Never pull out the plug by tugging the power-cord.

During the initial start-up some smoke or smell may arise. This is a normal process and does not necessarily mean that the device is defective.

Caution: During the operation, the housing becomes very hot.

Do not switch the device on and off in short intervals as this would reduce the lamp's life.

HEALTH HAZARD!
Never look directly into the light source, as sensitive persons may suffer an epileptic shock (especially meant for epileptics) !

Please consider that damages caused by manual modifications to the device are not subject to warranty.

Keep away children and amateurs !

2. Operating determinations

This device is a projector for creating decorative effects and was designed for indoor use only.

This device is designed for professional use, e.g. on stages, in discotheques, theatres etc.

Periodic inspections will ensure that the device will serve you for a long time without defects.

Never run the device without lamp!

Do not shake the device. Avoid brute force when installing or operating the device.

When choosing the installation-spot, please make sure that the device is not exposed to extreme heat, moisture or dust. There should not be any cables lying around. You endanger your own and the safety of others!

The minimum distance between light-output and the illuminated surface must be more than 1,0 meter.

Make sure that the area below the installation place is blocked when rigging, derigging or servicing the fixture.

Always fix the fixture with an appropriate safety-rope.

Only operate the fixture after having checked that the housing is firmly closed and all screws are tightly fastened.

The lamp must never be ignited if the fresnel-lens or any housing-cover is open, as discharge lamps may explode .

The maximum ambient temperature t_a must never be exceeded.

CAUTION! *The lens has to be replaced when it is obviously damaged, so that its function is impaired, e. g. due to cracks or deep scratches!*

Operate the device only after having familiarized with its functions. Do not permit operation by persons not qualified for operating the device. Most damages are the result of unprofessional operation!

CAUTION! *The lamp has to be replaced when it is damaged or deformed due to the heat!*

Please use the original packaging if the device is to be transported.

Please consider that unauthorized modifications on the device are forbidden due to safety reasons!

Never remove the serial barcode from the device as this would make the guarantee void.

If this device will be operated in any way different to the one described in this manual, the product may suffer damages and the guarantee becomes void. Furthermore, any other operation may lead to dangers like short-circuit, burns, electric shock, lamp explosion, crash etc.

3. Description of the device

- 1 - Fresnel lens
- 2 - Mounting bracket
- 3 - Rear cover
- 4 - Adjusting screw
- 5 - Front cover
- 6 - Control board
- 7 - Fans
- 8 - DMX output
- 9 - DMX input
- 10 - Lamp cover
- 11 - Power cord
- 12 - Fuse holder
- 13 - Power switch
- 14 - Display
- 15 - Mode-button
- 16 - Enter-button
- 17 - Up-button
- 18 - Down-button

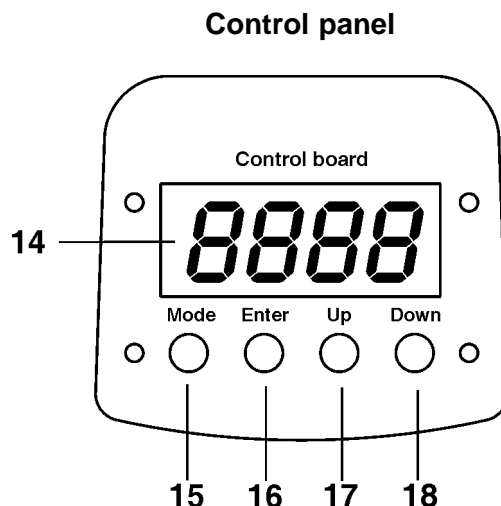
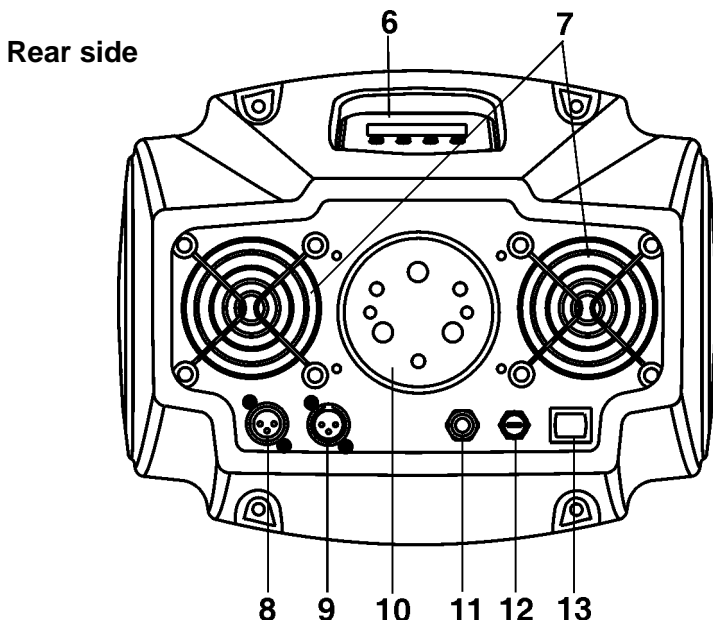
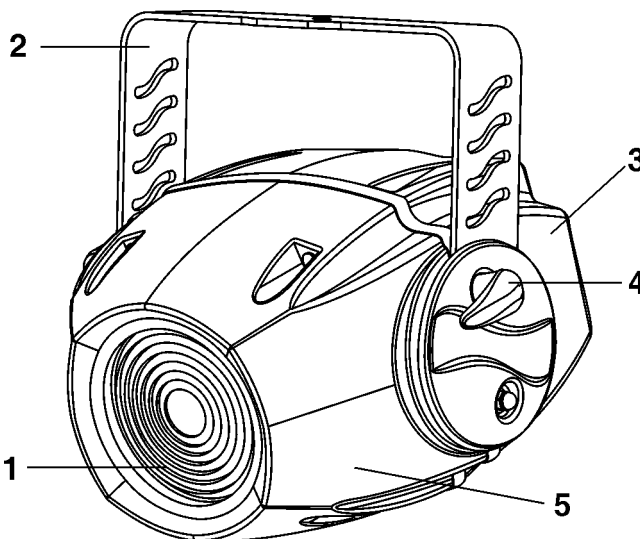

4. Installation

4.1 Fitting/Exchanging the lamp

DANGER ! Install the lamp with the device switched off only.
Unplug from mains before !

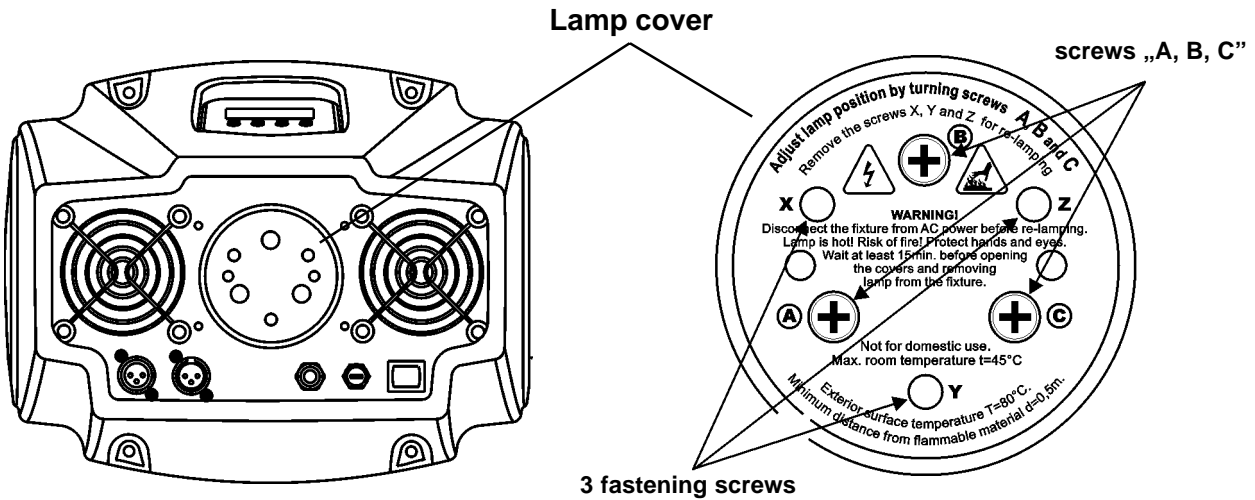

To insert the lamp MSD 250W/2 open the small cover at the rear of the projector by loosening the 3 screws „X, Y, Z” on the lamp cover.

Gently pull out the lamp socket assembly.

If changing the lamp, remove the old lamp from the socket. Insert the lamp to the socket.

Do not install a lamp with a higher wattage! A lamp like this generates temperatures the device is not designed for.

Damages caused by non-observance are not subject to warranty. Please follow the lamp manufacturer's notes!

Do not touch the glass-bulb bare hand during the installation! Make sure that the lamp is installed tightly into the lamp holder system.

Reinsert the lamp assembly and tighten the 3 screws again.

Before striking the lamp, reset the „LATi/rSEt” and „LASi/rSEt” counters in the „InFO” menu on the control panel, by pressing the [Up] and [Down] buttons in one time and then confirming with the [Enter] button.

Do not operate this fixture with opened housing-cover!

4.2 Lamp adjustment

The lamp holder is aligned at the factory. Due to differences between lamps, fine adjustment may improve light performance. Strike the lamp, cancel all effects, open the shutter and set the dimmer intensity to maximum and focus the light on a flat surface (wall) or use function „LAAd” in the **Special functions** of the control board.

Center the hot-spot (the brightest part of the beam) using the 3 adjustment screws „A, B, C”. Turn one screw at a time to drag the hot-spot, diagonally across the projected image. If you cannot detect a hot-spot, adjust the lamp until the light is even.

To reduce a hot-spot, pull the lamp in by turning all three screws „A, B, C” clockwise 1/4-turn at a time until the light is evenly distributed.

If the light is brighter around the edge than it is in the center, or if light output is low, the lamp is too far back in the reflector. „Push” the lamp out by turning the screws „A, B, C” counterclockwise 1/4-turn at a time the light is bright and evenly distributed.

4.3 Installation of the barn-doors

You can install the barn-doors to better define the illuminated surface. The barn-doors are fixed with the 2 screws and may be turned in range 90°.

Note: The barn-doors are not standard part of delivery, only on demand.

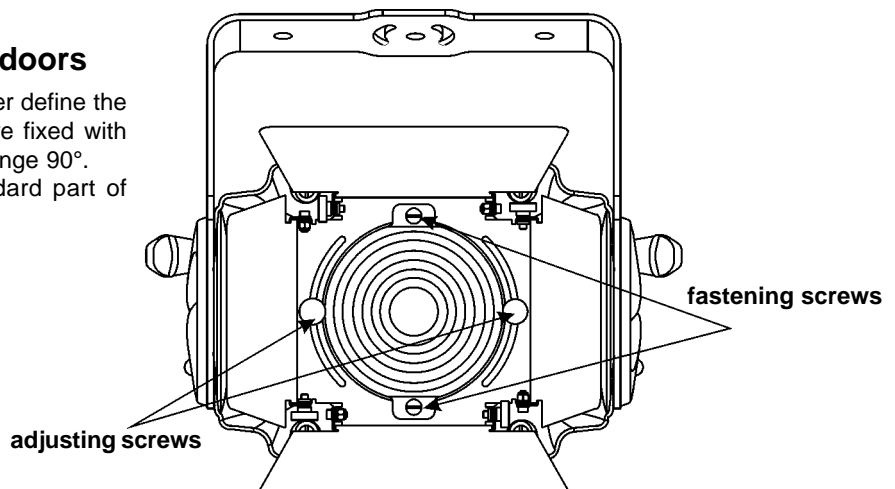

4.4 Manually adjustment of the beam angle

The lens system can be configured in the range between 8° and 22° beam angles. To set the desired beam angle, remove the barn-doors (if they are installed) by loosening the 2 fastening screws and open the front cover by loosening the 4 quarter turn fasteners, loose the 2 adjusting screws (with knurled-head) on the fresnel lens unit and adjust the required beam angle. Tighten the adjusting screws again and fix back the front cover and barn-doors.

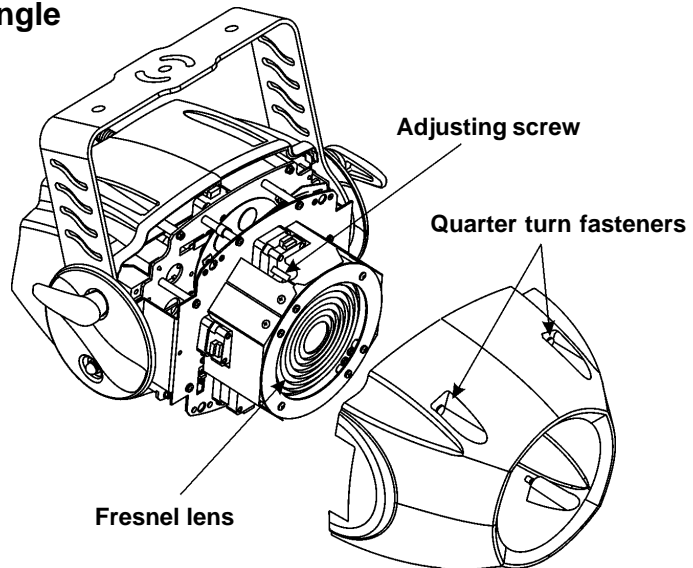

4.5 Rigging

DANGER TO LIFE!

***Please consider the respective national norms during the installation!
The installation must only be carried out by an authorized dealer!***

The installation of the projector has to be built and constructed in a way that it can hold 10 times the weight for 1 hour without any harming deformation.

The installation must always be secured with a secondary safety attachment, e.g. an appropriate catch net. This secondary safety attachment must be constructed in a way that no part of the installation can fall down if the main attachment fails.

When rigging, derigging or servicing the fixture staying in the area below the installation place, on bridges, under high working places and other endangered areas is forbidden.

The operator has to make sure that safety-relating and machine-technical installations are approved by an expert before taking into operation for the first time and after changes before taking into operation another time.

The operator has to make sure that safety-relating and machine-technical installations are approved by an expert after every four year in the course of an acceptance test.

The operator has to make sure that safety-relating and machine-technical installations are approved by a skilled person once a year.

The projector should be installed outside areas where persons may walk by or be seated.

IMPORTANT! OVERHEAD RIGGING REQUIRES EXTENSIVE EXPERIENCE, including (but not limited to) calculating working load limits, installation material being used, and periodic safety inspection of all installation material and the projector. If you lack these qualifications, do not attempt the installation yourself, but instead use a professional structural rigger. Improper installation can result in bodily injury and/or damage to property.

The projector has to be installed out of the reach of people.

If the projector shall be lowered from the ceiling or high joists, professional trussing systems have to be used. The projector must never be fixed swinging freely in the room.

Caution: Projectors may cause severe injuries when crashing down! If you have doubts concerning the safety of a possible installation, do NOT install the projector!

Before rigging make sure that the installation area can hold a minimum point load of 10 times the projector's weight.

Danger of fire ! ***When installing the device, make sure there is no highly inflammable material (decoration articles, etc.) in between a distance of min. 0,5 m.***

CAUTION! ***Make sure that the device is fixed properly! Ensure that the structure (truss) to which you are attaching the fixtures is secure.***

The projector can be placed directly on the stage floor or rigged in any orientation on a truss without altering its operation characteristics .

Overhead installation.

The mounting bracket provides 3 holes (a diameter of 13 mm) and 2 quarter-circle slots. To adjust the inclination-angle, loosen the 2 adjusting screws. Turn the projector to the desired angle and retighten the adjusting screws. For overhead use, always install a safety rope that can hold at least 10 times the weight of the fixture. Pull the safety rope through the mounting bracket and over the trussing system etc.

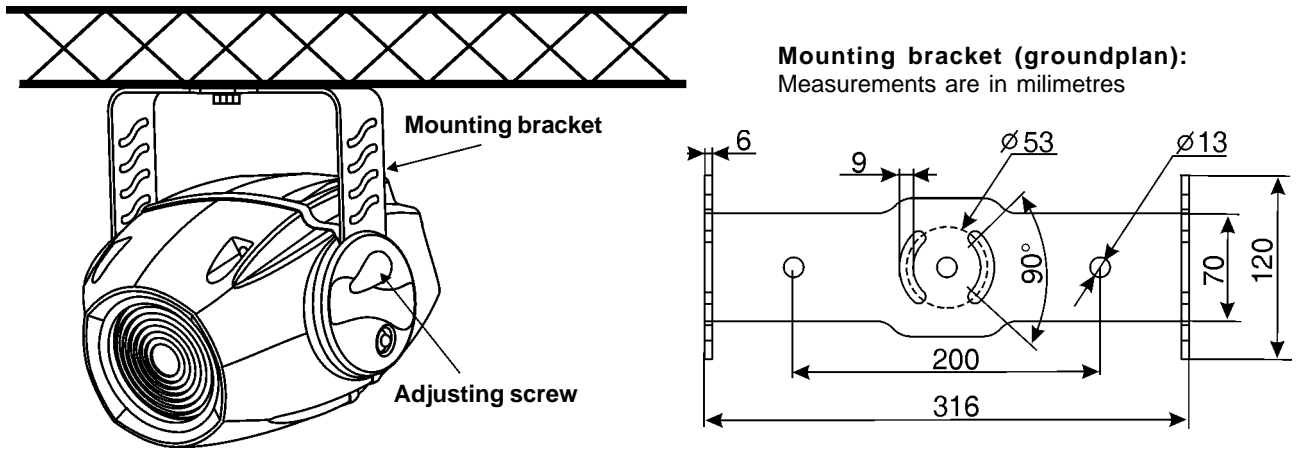

Floor installation.

The projector can stand directly on the floor by standing on the removable stand which is mounted with the nut M8 to the projector's mounting bracket.

Note: The barn-doors are not standard part of delivery, only on demand.

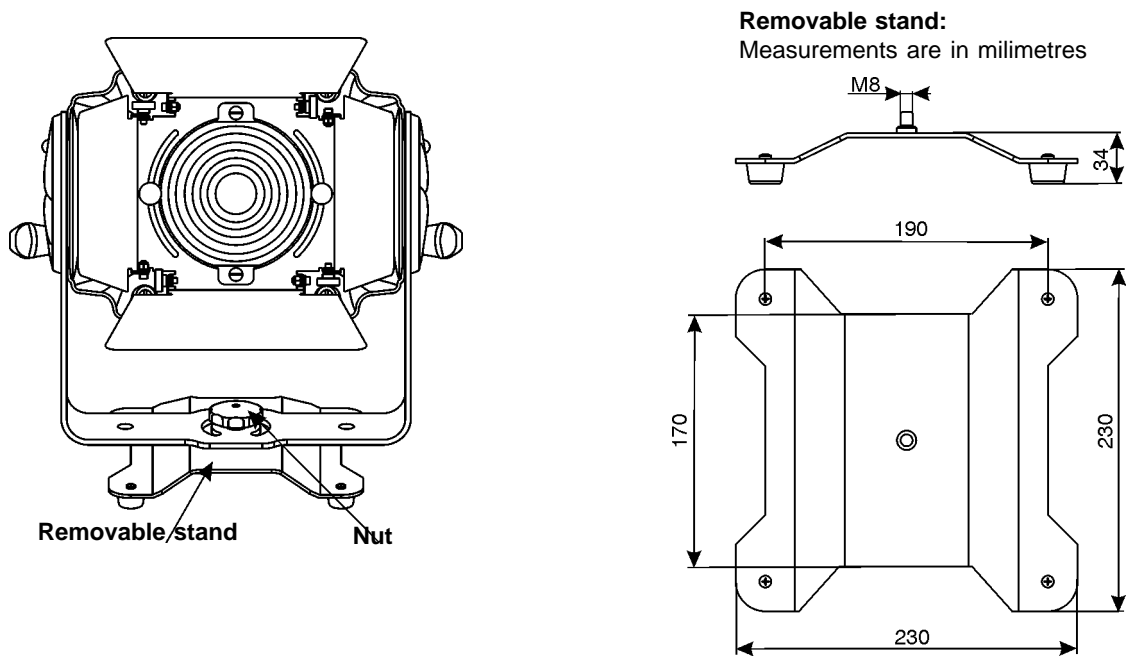

DANGER TO LIFE!
Before taking into operation for the first time, the installation has to be approved by an expert!
When installing fixtures side-by-side, avoid illuminating one fixture with another!

4.6 Connection to the mains

Verify the power supply settings before applying power!

If you wish to change the power supply settings, see the chapter Appendix. Connect the fixture to the mains with the enclosed power plug. If you need to install other power plug on the power cable, follow the identification table below. The earth has to be connected!

The occupation of the connection-cables is as follows:

Cable (EU)	Cable (US)	Pin	International
Brown	Black	Live	L
Light blue	White	Neutral	N
Yellow/Green	Green	Earth	

Do not connect the projector to a dimmer system!

4.7 DMX- 512 connection, master/slave connection

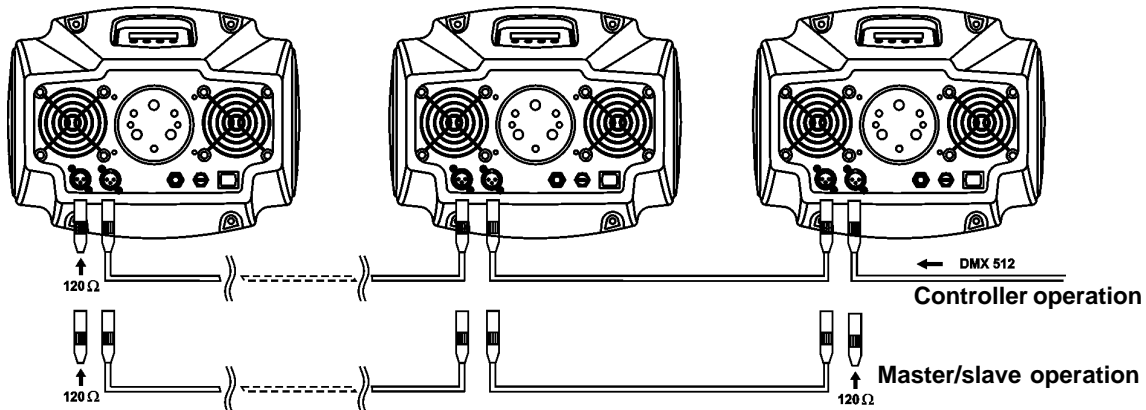

The wires must not come into contact with each other, otherwise the fixtures will not work at all, or will not work properly.

Only use a stereo shielded cable and 3-pin XLR-plugs and connectors in order to connect the controller with the fixture or one fixture with another.

Occupation of the XLR-connection:

XLR mounting-socket:

XLR mounting-plug:

DMX OUT



1 = GND
2 = SIG. -
3 = SIG. +

DMX IN



Building a serial DMX-chain:

If you are using the standard controllers, you can connect the DMX-output of the controller directly with the DMX-input of the first fixture in the DMX-chain. If you wish to connect DMX-controllers with other XLR-outputs, you need to use adapter-cables.

Connect the DMX-output of the first fixture in the DMX-chain with the DMX-input of the next fixture. Always connect output with the input of the next fixture until all fixtures are connected.

Caution: At the last fixture, the DMX-cable has to be terminated with a terminator. Solder a 120 Ohm resistor between Signal (-) and Signal (+) into a 3-pin XLR-plug and plug it in the DMX-output of the last fixture.

Building a master/slave-chain:

Connect the DMX-output of the master fixture in the data-chain with the DMX-input of the first slave. Always connect output with the input of the next slave until all slaves are connected (up to 9 fixtures).

Caution: It's necessary to insert the XLR termination plug (with 120 Ohm) into the input of the master fixture and into the output of the last slave fixture in the link in order to ensure proper transmission on the data link.

5. DMX Protocol - 8 bit

Mode 1 Channel	Mode 2 Channel	Value	Function	Type of control
1	1	0 -127 128-139 140-229 230-239 240-255	Lamp On/Off, control of fans From max. to min. speed of fans Lamp On after 3 seconds, reset No function Lamp Off after 3 seconds No function	proportional step step step step
2			No function	
3	2	0-255	Cyan Cyan (0 - white, 255 - full cyan)	proportional
4	3	0-255	Magenta Magenta (0-white, 255 full magenta)	proportional
5	4	0-255	Yellow Yellow (0-white, 255-full yellow)	proportional
6	5	0-255	Speed of CMY and dimmer Speed from max. (0) to min. (255)	proportional
7	6	0-7 8-15 16-23 24-31 32-39 40-47 48-55 56-63 64-71 72-79 80-87 88-95 96-103 104-111 112-119 120-127 128-135 136-143 144-151 152-159 160-167 168-175 176-183 184-191 192-199 200-207 208-215 216-223 224-231 232-239 240-247 248-255	Colour macros Off Macro 1 Macro 2 Macro 3 Macro 4 Macro 5 Macro 6 Macro 7 Macro 8 Macro 9 Macro 10 Macro 11 Macro 12 Macro 13 Macro 14 Macro 15 Macro 16 Macro 17 Macro 18 Macro 19 Macro 20 Macro 21 Macro 22 Macro 23 Macro 24 Macro 25 Macro 26 Macro 27 Macro 28 Macro 29 Macro 30 Macro 31	step step
8			No function	
9			No function	
10	7	0-31 32-95 96-127 128-159 160-175 176-191 192-223 224-255	Shutter, strobe, reset Shutter closed Shutter open Strobe-effect from slow to fast (max.10 flashes/s) Shutter closed Pulse-effect in sequences with increasing speed Pulse-effect in sequences with decreasing speed Random strobe-effect with increasing speed Shutter open	step step proportional step proportional proportional proportional step
11	8	0-255	Dimmer intensity Intensity from 0 to 100%	proportional

The ColorMix 240 AT can be operated with a controller in **controller mode** or without the controller in **stand-alone mode**. Both modes are described in the texts below.

6. Controller mode

The fixtures are individually addressed (001-502) on a data link and connected to the controller. The fixtures respond to the DMX signal from the controller.

6.1 DMX addressing

The control panel on the front side of the base allows you to assign the DMX fixture address, which is defined as the first channel from which the ColorMix 240 AT will respond to the controller.

If you set, for example, the address to channel 5, the ColorMix 240 AT will use the channel 5 to 15 for control.

Please, be sure that you don't have any overlapping channels in order to control each ColorMix 240 AT correctly and independently from any other fixture on the DMX data link.

If two, three or more ColorMix 240 AT are addressed similarly, they will work similarly.

For address setting, please refer to the instructions under „Addressing”(menu „**A001**”).

Controlling:

After having addressed all ColorMix 240 AT, you may now start operating these via your lighting controller.

Note: After switching on, the ColorMix 240 AT will automatically detect whether DMX 512 data is received or not. If there is no data received at the DMX-input, the display will start to flash „**A001**” with actually set address.

This situation can occur if:

- the 3 PIN XLR plug (cable with DMX signal from controller) is not connected with the input of the ColorMix 240 AT
- the controller is switched off or defective, the cable or connector is defective or the signal wires are swap in the input connector.

Note: It's necessary to insert the XLR termination plug (with 120 Ohm) to the last fixture in the link in order to ensure proper transmission on the DMX data link.

6.2 Remotely controllable functions

Lamp

The ColorMix 240 AT is to be operated with a MSD 250W/2 GY-9,5 lamp.

A relay inside of the ColorMix 240 AT allows you to switch on and off the lamp via the control panel on the top side of the projector or via your controller without affecting the rest of the lighting.

To switch On/Off the lamp, please refer to „Switching On/Off the lamp” (menu „**LAMP**”).

Note: It is also important to note, that the discharge lamp is cold restrike types, that means, that they have to be cold before re-striking. For this reason, you have to wait 5 minutes (max. speed of fan must be adjusted) after having switched Off the lamp before you can switch it back On again. If you try to switch On the lamp within 5 minutes after having switched it Off, the ColorMix 240 AT will store this information and automatically ignite the lamp when the 5 minutes period has expired. The message „**HEAT**” will appear on the control panel display of the ColorMix 240 AT. If the ignition of the lamp is seven times unsuccessful, on the display will appear „**LA.Er**”, meaning that the lamp could be damaged or even missed, or there could be a failure on the ignitor or ballast.

CMY-colours mixing system

The CMY color mixing system is based on graduated cyan, magenta, and yellow color filters. A continuous range of colors may be achieved by varying the amount of each filter from 0 to 100%.

Dimmer

Smooth 0 - 100 % dimming is provided by the special dimmer unit.

Shutter/Strobe

Extremely fast shutter may also be used for strobe effect (1 - 10 flashes per second).

Fans

The ColorMix 240 AT is cooled by the two axial fans . The speed of the fans (and of course the noise) can be continuously reduced if very quiet performance is required.

By the control board using the „**FANS**” function you can choose 5 types of the fan speed operating modes.

7. Stand - alone mode

The fixtures on a data link are not connected to the controller but can execute pre-set programs which can be different for every fixture. To set the program to be played, see the „Stand-alone setting” (menu „**St.AL.**”).

„Stand-alone operation” can be applied to the single fixture (the fixture may be set to the master /slave mode or controller mode) or to multiple fixtures operating synchronously.

Synchronous operation of multiple fixtures requires that they must be connected on a data link and one of them is set as a master (master mode) and the rest as the slaves (slave mode). The slaves are assigned to SLA1-SLA9 and on the certain slave address can be connected only one fixture. To set the fixture as the master or slave, see the „Addressing” (menu „**A001**”).

If the master fixture runs a reset or plays test (program), all slaves will execute these acts too.

You can't play or edit any programs on the slaves by their control panels if the master is switched on and connected to the master/slave chain.

The master fixture starts simultaneous program start in the other slave fixtures. All fixtures have a definite, synchronized starting point when playing back their programs. The number of running program is the same in all slaves and depends on the master's choice (menu „St.AL.”). Every fixture runs its program repeatedly, starting the program step No.1 when requested by the master.

For example:

If the slave fixture has a shorter program length, it will continuously repeat its program until the master fixture finishes its own program and restarts its program running (slave 1- prog.step 3 will not be finished).

If the slave fixture has a longer program length, it will restart at prog. step 1 before it completes all its prog.steps (slave 2 - prog.step 5 will not be played)- see the picture bellow.

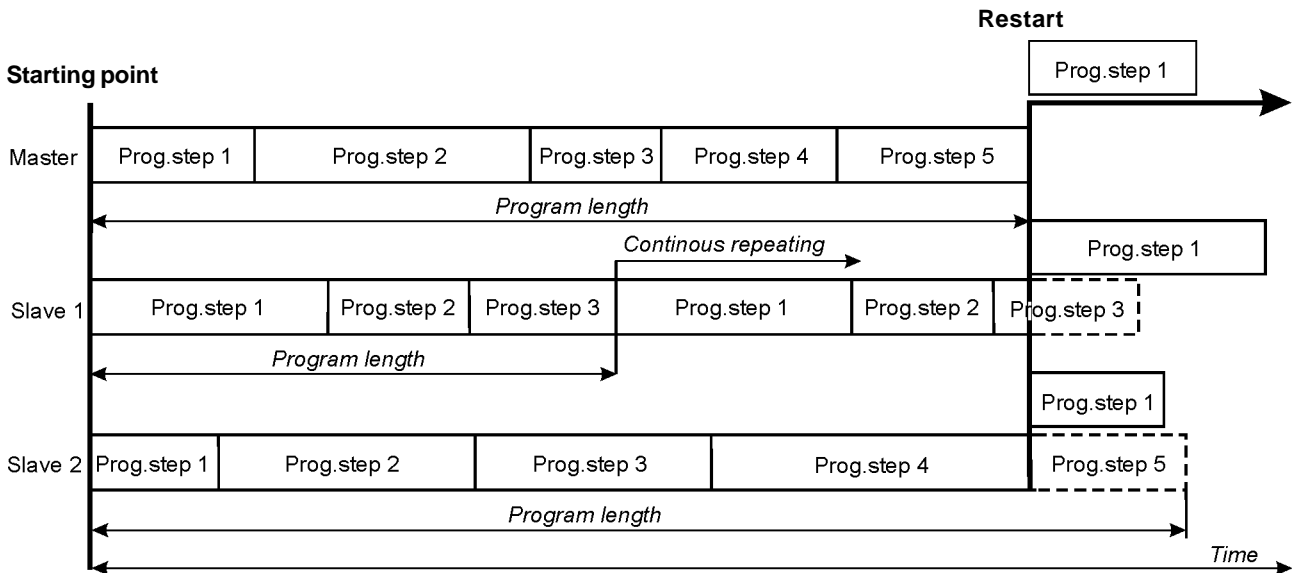

Note: Disconnect the fixtures from the DMX controller before master/slave operating, otherwise data collisions can occur and the fixtures will not work properly!

It's necessary to insert the XLR termination plug (with 120 Ohm) into the input of the master fixture and into the output of the last slave fixture in the data link in order to ensure proper transmission on the data link.

From the master's control panel is possible to control any slave in a master/slave chain.

8. Functions of the control panel

The control panel situated on the front side of the base offers several features. You can simply set the DMX address, master/slave mode, read the number of lamp or unit hours, run test, make a reset and also use many functions for setting and service purposes.

The main menu of the control panel is accessed by pressing the **[Mode]** button - press this one so many times until the display shows message „A001” (with actually stored address). Browse through the menu by the pressing **[Up]** or **[Down]** buttons - the display shows step by step these messages: **A001, SLct, InFO, PErS, LAMP, tESt, StAL, rESE, SPEC**. Press **[Enter]** if you wish to select one of them. The functions are described in the following sections and the function hierarchy is shown below.

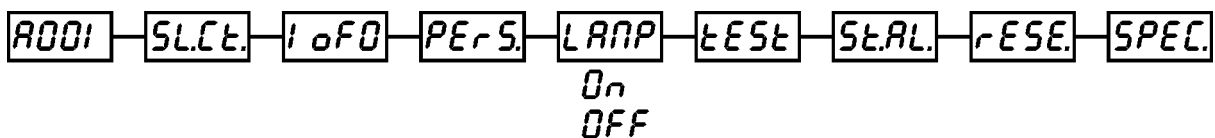

A001 - 8.1 Addressing

By this menu you can set the DMX address or address the fixture as a master/slave.

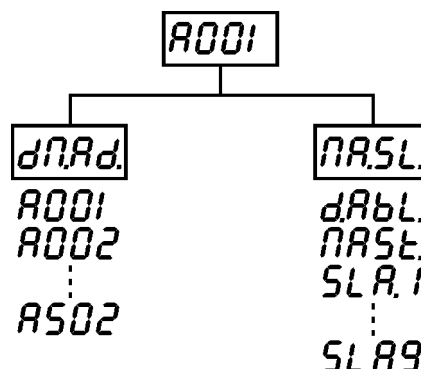

dMAd. - DMX addressing

1. Press the **[Mode]** - button so many times until the display shows message „**A001**” (with actually stored address).
 2. Press **[Enter]** - button and use the **[Up]** and **[Down]** buttons to select „**dM.Ad.**”- menu.
 3. Press **[Enter]** - button (the letter „**A**” flashes) and by **[Up]** and **[Down]** buttons select required address (001 - 501), press **[Enter]** - button to confirm.
 4. Select „**M.ASL.**”- menu, press **[Enter]**-button and use **[Up]** and **[Down]** buttons to select „**d.AbL.**” (no master or slave), press **[Enter]** - button to confirm.
 5. Press the **[Mode]** - button. Chosen address is shown on the display.
- If message „**A001**” (with actually stored address) flashes-no DMX data received at the DMX-input.

nRSL. - Master/slave addressing

1. Press the **[Mode]** - button so many times until the display shows message „**A001**” (with actually stored address).
 2. Press **[Enter]** - button and use the **[Up]** and **[Down]** buttons to select „**MA.SL.**” - menu.
 3. Press **[Enter]** - button (display flashes) and select „**MASt**” (to set the fixture as the master in a chain of multiple fixtures) or „**SLA.1 - SLA.9**” (to set the fixture to be the slave in a chain of multiple fixtures) and press **[Enter]** to confirm. If you want address no master or slave, select „**d.AbL.**”.
 4. Press the **[Mode]** - button. Chosen address is shown on the display.
- If message „**MASt.**” fast flashes - DMX signal is received at the DMX-input - disconnect DMX controller!

Only one fixture may be the master. Up to the 9 slaves may be connected to the master and on the certain address can be connected only one slave fixture („SLA1-SLA9”).

Note: Disconnect the fixtures from the DMX controller before master/slave operating, otherwise data collisions can occur and the fixtures will not work properly!

If the fixture is set as the master and DMX signal is connected to its input, the error message „**MAEr**” will appear on its display and the fixture's address will be set to its DMX address in order to respond to DMX signal from the controller.

For example:

The master fixture has this address setting: „**dM.Ad.**” - menu.....**A012**
 „**MA.SL.**” - menu.....**MASt** (is displayed)

The DMX signal is connected to the master fixture. The message „**MASt**” starts fast flashing and after 20s error message „**MA.Er**” appears on its display and the fixture automatically will be switched to its DMX address (master address is disabled). Now the fixture has the address setting: „**dM.Ad.**” - menu.....**A012** („A012/MA.Er” blinks)
 „**MA.SL.**” - menu.....**d.AbL.**

If the fixture is set as the slave and DMX signal is connected to its input, the fixture will respond to DMX signal from the controller (in dependence on the fixture's DMX address).

- 8.2 Slave control

This function allows you to control the slaves from the master's control panel in a master/slave operation. Select this function from the main menu and press **[Enter]** - button. Browse the list of all connected slaves („**SL.C.1 - SL.C.9**”) by pressing **[Up]** and **[Down]** buttons. Select the desired slave and press **[Enter]** - button. The slave's control panel is available from the master's control panel.

If no slave is connected to the master, messages „SL.C.1”, „SL.C.2”, „SL.C.3”,...,„SL.C.9” still round repeat.

Note: This function is available from the master fixture only.

Info - 8.3 Fixture informations

The menu allows you to read an useful information about the fixture as the lamp life,lamp strikes,software version, etc. Press **[Up]** or **[Down]** buttons to select the desired option and press **[Enter]** to see the value or next submenu.

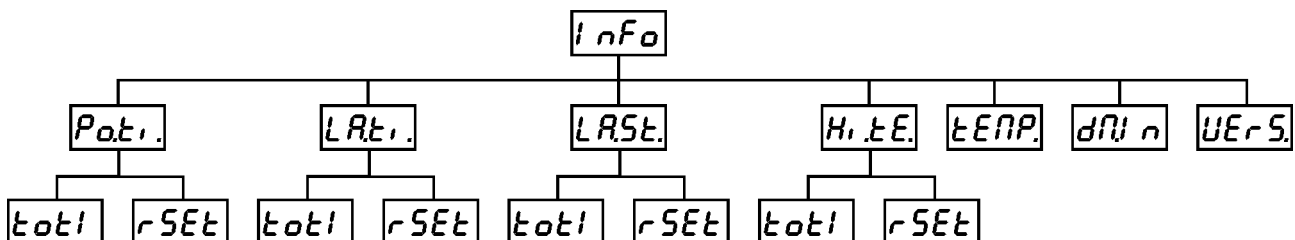

Pot. - Power On time

totl - By this option you can read the total number of the operation hours since the ColorMix 240 AT has been fabricated. Press **[Enter]** or **[Mode]** to return to the menu.

rSEt - The number of the hours that the ColorMix 240 AT has been powered on since the counter was last reset. Press **[Enter]** or **[Mode]** to return to the menu. In order to reset this counter to 0, you have to hold the **[Up]** and **[Down]**-button and press the **[Enter]**-button.

LA.t. - Lamp On time

totl - This option enables you to read the total number of the operation hours with the lamp on since the ColorMix 240 AT has been fabricated. Press **[Enter]** or **[Mode]** to return to the menu.

rSEt - The number of hours that the lamp has been powered On since the counter was last reset. Press **[Enter]** or **[Mode]** to return to the menu. In order to reset this counter to 0, you have to hold the **[Up]** and **[Down]**-button and press the **[Enter]**-button.

LASt. - Lamp strikes

totl - By this option you can read the total number of the lamp strikes since the ColorMix 240 AT has been fabricated. Press **[Enter]** or **[Mode]** to return to the menu.

rSEt - The number of the lamp strikes since the counter was last reset. Press **[Enter]** or **[Mode]** to return to the menu. In order to reset the counter to 0, you have to hold the **[Up]** and **[Down]**-button and press the **[Enter]**-button.

Hi.tE. - Max. fixture temperature

totl - By this option you can read the max. temperature of the fixture inside since the ColorMix 240 AT has been fabricated. Press **[Enter]** or **[Mode]** to return to the menu.

rSEt - Max. temperature of the fixture inside since the counter was last reset. Press **[Enter]** or **[Mode]** to return to the menu. In order to reset the counter to 0, you have to hold the **[Up]** and **[Down]**-button and press the **[Enter]**-button.

tENP. - Current fixture temperature

Temperature readouts of the fixture inside in Celsius. Inside temperatures below 86°C are not critical. 86°C and more lead to the lamp being switched off. Please note that the outside temperature should not exceed 40°C.

dNI n. - DMX values

Readout DMX values of each channel received by the fixture. Use the **[Up]** and **[Down]** buttons to select desired channel and press **[Enter]** to read its value coming to the fixture or **[Mode]** to cancel and return to the menu.

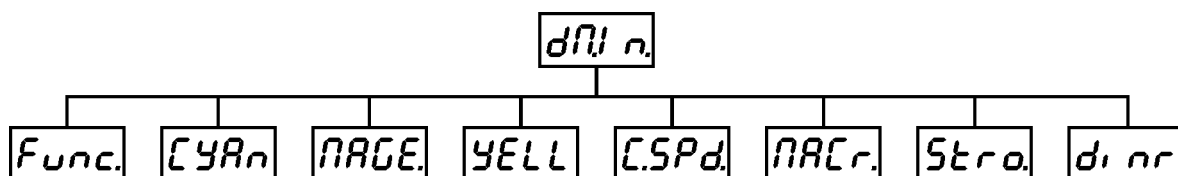

UErS. - Software version

By this function you can read the software version of the display module. Press **[Enter]** to read its value or **[Mode]** to return to the menu.

PErS. - 8.4 Personality options

These options allow you to modify ColorMix 240 AT operating behavior.

Press **[Up]** and **[Down]** buttons to select the desired option and press **[Enter]** to set the value or to see next submenu.

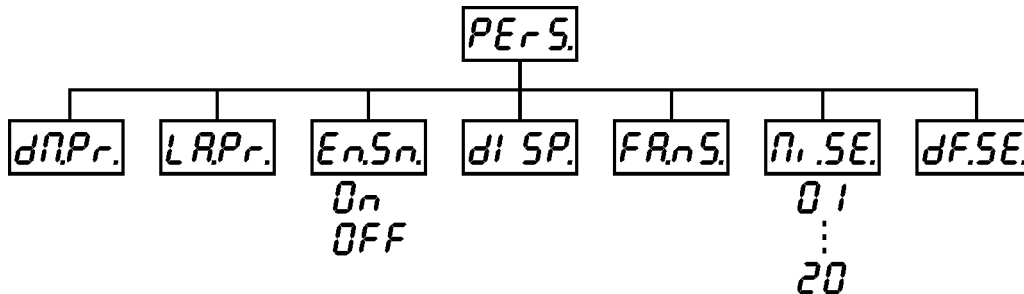

dNPr. - DMX presetting

The function makes possible to select from the 2 DMX- channels settings. Use the **[Up]** or **[Down]** buttons to select desired channel settings („Mod.1, Mod.2”) and press **[Enter]** to confirm or **[Mode]** to cancel and return to the menu.

Channel	Mode 1 (default)	Mode 2
1	Lamp On/Off, reset	Lamp On/Off, reset
2	No function	Cyan
3	Cyan	Magenta
4	Magenta	Yellow
5	Yellow	Speed of CMY
6	Speed of CMY	Colour macros
7	Colour macros	Effect-wheel
8	No function	Shutter, strobe
9	No function	Dimmer intensity
10	Shutter, strobe	
11	Dimmer intensity	

Please refer to the chapter „DMX- protocol” for detail description.

LARr. - Lamp presetting

This function allows you to adjust the lamp settings:

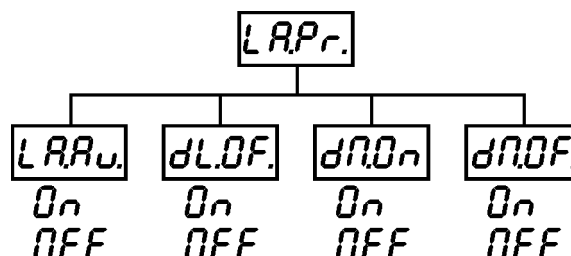

LARu. - Lamp On after switching the fixture On

This function enables to turn the lamp on automatically after switching the fixture on. Use the **[Up]** and **[Down]** buttons to select „On” if you wish to turn the lamp on automatically after switching the fixture on or „Off” if you wish the lamp off after switching on the fixture and press **[Enter]** to confirm or **[Mode]** to cancel and return to the menu.

dL.OF. - Lamp Off via DMX

This function allows you to switch off the lamp by DMX. Use the **[Up]** and **[Down]** buttons to select „On” if you want to switch off the lamp by DMX or „Off” if you don't want to switch off the lamp by DMX and press **[Enter]** to confirm or **[Mode]** to cancel and return to the menu.

dOn - Lamp On if DMX is present

This function allows you to strike the lamp automatically after 26 seconds if DMX signal is present on the data link. If the ignition is unsuccessful (e.g.lamp is too hot), the fixture will try to ignite the lamp after next 26 sec.This process will repeat until the lamp lights. Use the **[Up]** and **[Down]** buttons to select „On” if you want to strike the lamp or „Off” if you don't want to strike the lamp and press **[Enter]** to confirm or **[Mode]** to cancel and return to the menu.

dOff. - Lamp Off if DMX is missing

This function allows you to switch Off the lamp automatically after 2 minutes if DMX signal is missing on the data link. Use the **[Up]** and **[Down]** buttons to select „On” if you want to switch Off the lamp or „Off” if you don't want to switch Off the lamp and press **[Enter]** to confirm or **[Mode]**to cancel and return to the menu.

En.Sn. - Switch On/Off the lamp light sensor

Use the **[Up]** and **[Down]** buttons to select „On” if you wish to switch the lamp light sensor on and press **[Enter]** to confirm or **[Mode]** to cancel and return to the menu. **The option „On” is for the standard operation.** Use the **[Up]** and **[Down]** buttons to select „Off” if you wish to switch the lamp light sensor Off and press **[Enter]** to confirm or **[Mode]** to cancel and return to the menu.

Important: The option „Off” is for „emergency operation” only if the lamp light sensor is defective and you will wait for a service intervation! If the lamp light sensor is switched Off, the error messages „LAEr, SnEr, HEAt” will not appear on the display (only the message „HEAt” will appear if the lamp was turned off and on within 5 minutes) and at switching the lamp on the electronics will still try to ignite the lamp until it shines (even when the lamp is damaged or absent), on this account some electronics parts could be damaged!

di SP. - Display adjusting

This function allows you to adjust the display settings:

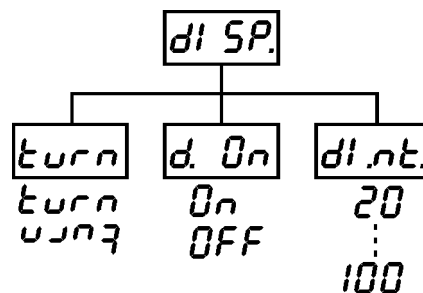

di.nt. - Display-intensity

With this function you can adjust the display intensity from 20% to 100% . Use the **[Up]** or **[Down]** buttons to select the level of the display intensity and press **[Enter]** to confirm or **[Mode]** to cancel and return to the menu.

turn - Display-reverse

With this function, you can rotate the display by 180°. Use the **[Up]** or **[Down]** buttons to select „normal display” or „display turned by 180°” and press **[Enter]** to confirm or **[Mode]** to cancel and return to the menu.

d. On - Display-On

This function allows you to keep the display on or to turn off automatically 2 minutes after last pressing any button on the control panel. Use the **[Up]** or **[Down]** buttons to select „On” if you wish to keep the display on or „Off” if you wish to turn off automatically 2 minutes after last pressing any button on the control panel and press **[Enter]** to confirm or **[Mode]** to cancel and return to the menu.

FAN.S. - Fan speed operating modes

By using this function you can choose 5 types of the fan speed operating modes. Browse through this menu by the pressing **[Up]** and **[Down]** buttons - the display shows step by step these messages: „Auto, HIGH, reG, LoOF, LoHI”. Press **[Enter]** if you wish to select one of them or **[Mode]** to cancel and return to the menu.

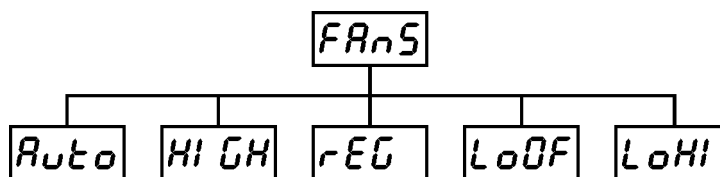

Auto - Continuous controlling of the fan speed without the DMX value

The fans automatically raise their speed in order to control inside temperature of the lighting, if the temperature inside increases about certain level (the low fan speed reduces the cooling of the lighting). This cycle can repeat several times until the temperature inside is on suitable level. The initial level of the fan speed can't be adjusted by the DMX.

HI GH - High (max.) speed of fans

The cooling fans work on max. speed (max. cooling)

reG - Continuous controlling of the fan speed

This mode is similar to „Auto”, but the initial level of the fan speed can be adjusted by the DMX.

LoOF - Low speed/Switch Off the lamp operating

The fans keep the adjusted low speed until the temperature exceeds max. inside temperature of the fixture, then the fixture automatically switches off the lamp.

LoHI - Low/high speed of the fan operating

The fans keep the adjusted low speed until the temperature exceeds max. inside temperature of the fixture, then the fixture automatically switches from low to high the fan speed.

Note: The modes „Auto” and „HIGH” don't interact to the DMX value on the channel 1 (0-127) !

M.S.E. - Microphone - sensitivity

With this function you can adjust the microphone sensitivity from 1 (maximum) to 20 (minimum) . Use the **[Up]** or **[Down]** buttons to select the level of the microphone sensitivity and press **[Enter]** to confirm the chosen level or **[Mode]** to cancel and return to the menu.

Example:

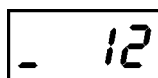

underexited

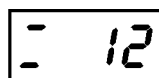

right level

(upper segment blinks by the bass rhythm)

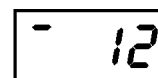

overexited

dFSE. - Default settings

Press **[Enter]** to reset all fixture personalities (not the adjusting functions) to the default values. On the display will appear „rSt” meaning that the fixture makes the reset. See the table of personality setting and their default positions.

LAMP. - 8.5 Switching On/Off the lamp

Press the **[Mode]** button in order to access the main menu. Browse through the menu by pressing the **[Up]** and **[Down]** buttons until the display shows „LAMP”. Confirm by pressing **[Enter]** button.

Use the **[Up]** and **[Down]** buttons to select „On” to switch On the lamp and „Off” to switch Off the lamp and press **[Enter]** to confirm or **[Mode]** to cancel.

tEST. - 8.6 Test sequences

This function allows you to run a special demo-test sequences without an external controller, which will show you some possibilities of using ColorMix 240 AT. Press **[Enter]**-button to run the test. If the test program is running, messages „run/test” blink on the display.

If you want to pause the running program in the required position, press the **[Enter]** button (messages „PAUS”/„test” blink). To continue the program running, press the **[Enter]**-button again.

StAL. - 8.7 Stand-alone setting

This menu offers options for stand-alone mode as a selection of the playing program, programming and modifying current programs.

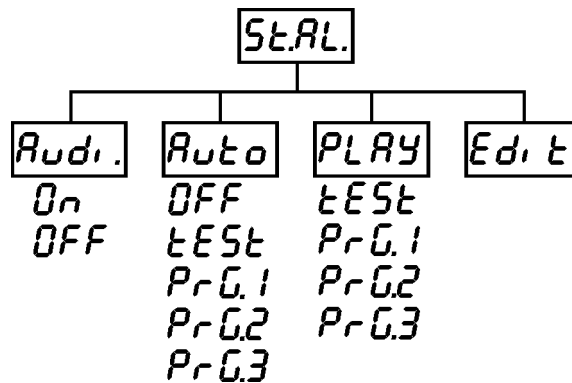

Audi - Music trigger

The ColorMix 240 AT enables the sound control of the running programs via the built-in microphone. Use the [Up] or [Down] buttons to select „On” if you wish this feature or „Off” if you don't wish this feature and press [Enter] to confirm or [Mode] to cancel and return to the menu.

Auto - Presetting playback

This function allows you to select the program which will be played in the stand-alone mode after switching the fixture On. Use the [Up] or [Down] buttons to select desired program („tEst”- built-in program) or „OFF” if you don't want trigger any program after switching the fixture On and press [Enter] to confirm or [Mode] to cancel and return to the menu. Selected program will be played continuously in a loop as long as it appears on the display.

This option should be set „OFF” for all slaves in the master/slave chain by reason of the right program starts.

For example: You have selected program „PrG.3” in this menu and:

This fixture is set as a single fixture (master/slave or controller operating)- the fixture will run its program „PrG.3”.

This fixture is set as a master in a data chain- the fixture will run its program „PrG.3”.

This fixture is set as a slave in a data chain- the fixture will run its program according to the master (if the master runs its own program „PrG.1”, the slave will run its own program „PrG.1” also).

Note: If the fixture operates in the controller mode (DMX controller is connected) and any program from this menu is selected, in this case the fixture will not respond to the DMX controller after switching On and will play selected program.

PLAY - Playing program

This function allows you to run a built-in program „tEst” and the 3 freely-programmable programs „PrG.1, PrG.2, PrG.3”. Press [Up] or [Down] buttons to select the desired program and press [Enter] to run the program which will be played continuously in a loop.

If you want to pause the running program in the required position, press the [Enter]-button (messages „PAUS/program No.” blink). To continue the program running, press the [Enter]-button again.

Note: If the fixture operates in the controller mode (DMX controller is connected) and any program from this function is selected in this case the fixture will not respond to the DMX controller and will play selected program.

You can't play programs on the slave fixtures from their control panels if the master fixture is switched On and connected to the slaves (playing is forced by the master).

Edit - Editing program

This menu item allows you to select a program to edit or create. The ColorMix 240 AT has one built-in program („tEst”) and the 3 free programs, each up to 99 steps.

If the fixture is set as a master, then you may edit any program in the slaves. You can't edit programs on the slave fixtures from their control panels if the master fixture is switched on and connected to the slaves (editing is possible by the master control panel only).

Procedure:

1. Press [Up] or [Down]-button to select the program you want to edit („PrG.1” - „PrG.3”) and press [Enter].
2. Press [Up] or [Down]-button to select the desired fixture („MASt.” - „SLA.9”) and press [Enter]-button.
3. Press [Up] or [Down]-button to select the desired program step („St.01” - „St.99”) and press [Enter]-button.
4. Press [Up] or [Down]-button to select the desired item and press [Enter]-button. Now you can edit by [Up] or [Down] buttons the DMX value for selected item:

„P.End” - a total number of the program steps, value 1-99. **This value you must set before start programming** (e.g. if you want to create program with the 10 steps, set the value onto 10).

„CYAn” - a cyan, value 0-255

„MAGe.” - a magenta, value 0-255

„YELL.” - a yellow, value 0-255

„C.SPd” - a speed of CMY, value 0-255

„MACr.” - a colour macro, value 0-255

„Stro.” - a strobe, value 0-255

„dimr” - a dimmer, value 0-255

„S.tim.” - a step time, value 0,1-25,5 seconds

„COPY.” - a copying the current prog. step to the next prog. step. If the last prog. step is copied to the next

prog. step, parameter „P.End” is increased about 1 by itself (except step 99).

5. Press **[Enter]**-button to confirm adjusted value.

6. Press **[Mode]**-button, select next prog. step and repeat this procedure (steps 4 and 6).

The editing programs „PrG.1, PrG.2, PrG.3” are saved in the current modified fixture (master or slave1-9).

rESE. - 8.8 Reset function

Press **[Enter]** button to run a reset. This option enables the ColorMix 240 AT to index all effects (functions) and return to their standard positions.

SPEC. - 8.9 Special functions

Use the **[Up]** or **[Down]** buttons to browse through the special functions and select the one by pressing **[Enter]**-button.

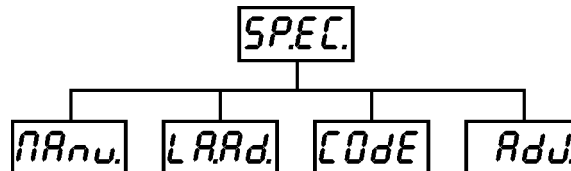

NAnu. - Manual control of effects

The function allows you to control manually the channel functions of the fixture. Use the **[Up]** or **[Down]** buttons to select desired function and press **[Enter]** to adjust the effect or **[Mode]** to cancel and return to the menu.

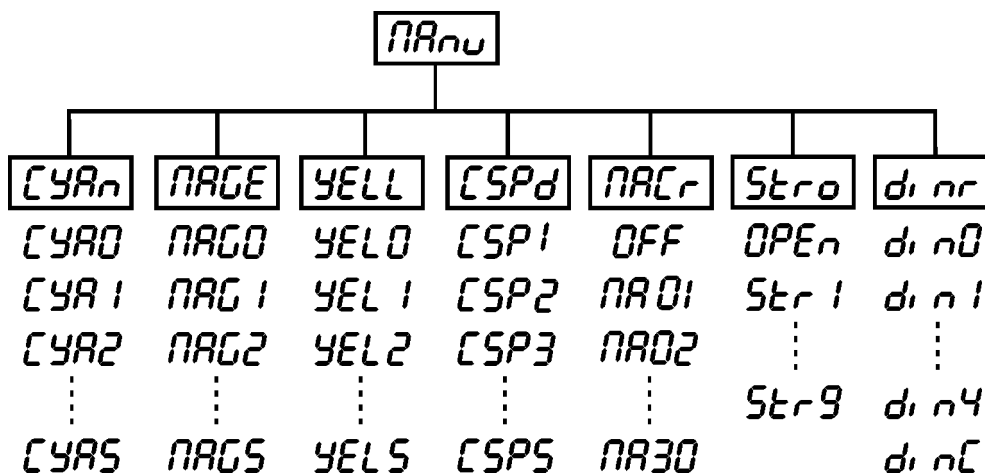

LAAAd. - Lamp adjustment

This function can be used when you make the fine adjustment of the lamp. If you select „LAAAd” pressing by **[Enter]**-button, all effects will be canceled, shutter will be opened and the dimmer intensity will be set to maximum. Now you can aim the light at a flat surface (wall) and perform the fine lamp adjustment.

COdE - Fixture code

The option contains identification code (1-9999) for the fixture, which is used for the master/slave operation.

AdJ. - Adjusting the effects to the required positions without DMX controller

By this function you can and adjust all effects to the required positions without DMX controller. Use the **[Up]** and **[Down]** keys to browse through the adjusting menu - the display shows step by step these messages: „Func, CYAn, MAGE, YELL, C.SPd, MACr, Stro, dimr” by which you can adjust the fixture to the required/ desired position (0-255).

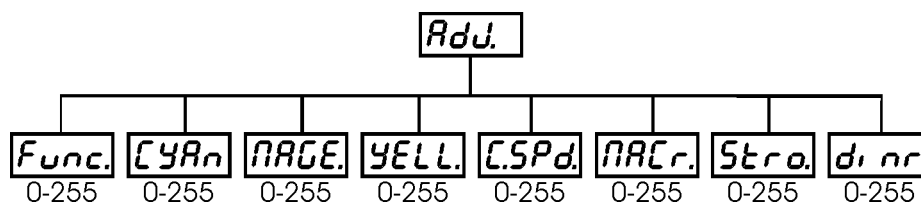

9. Error and information messages

HEAt

This message appears if you try to switch on the lamp within 5 minutes after having switched it off (the lamp is too hot). The message will appear on the display if the lamp doesn't ignite within 28 seconds. The fixture will store this information and automatically ignite the lamp when the 5 minutes period has expired.

Caution: The message is disabled if the lamp light sensor (function „En.Sn.“) is switched Off (only if the lamp was turned Off and On within 5 minutes, the message „HEAt“ will appear).

LAEr

The ignition of the lamp is seven times unsuccessful (the HEAt message appeared six times before), and the display shows „LA.Er“, meaning that the lamp could be damaged or even missed, the fixture is overheating (this can occur if the ambient temperature is 40° C or more) or there could be a failure on the ignitor or ballast.

Please place or replace the lamp, check the ambient temperature or contact your dealer if the situation was not caused by the lamp.

Caution: The message is disabled if the lamp light sensor (function „En.Sn.“) is switched Off.

FAn

The message informs you that the fixture was overheating and switched off. This message will appear on the display if the fan speed operating „LO.OF.“ was selected.

MbEr

This message informs you that the main PCB does not communicate correctly with the Control Panel.

FtEr

The message informs you that the fixture was overheating (occured if the ambient temperature is 40° C or more) and that the relay switched off the lamp. This message will appear on the display until the temperature will be on a suitable level, then the display will show the „HEAt“ message meaning the lamp is too hot.

SnEr

This message appears if the lamp lighting sensor is failed. Please, contact your dealer.

Caution: The message is disabled if the lamp light sensor (function „En.Sn.“) is switched Off.

PoEr

This message will appear if the fixture was shortly disconnect from the main.

MAEr (Master error)

The message informs you that the fixture was addressed as a master and DMX signal is connected to its input. Disconnect the DMX controller from fixture's input and address the fixture as the master again.

FrEr

It will appear if the frequency of the main is not standard 50 or 60Hz.

10. Technical specifications

Power supply:

EU-model: 208/230/240V AC, 50/60Hz ~	Fuse: T 3.15A @ 230V
US-model: 100/120/208/230/240V AC, 50/60Hz ~	Fuse: T 6.3A @120V
Power consumption: 390 VA	

Lamp

Philips MSD 250/2 GY-9.5

Colours

CMY - colours mixing system

Beam effects

Beam shaper
Frost filter

Strobe

Strobe effect with variable speed (1 - 10 flashes per second)

Dimmer

Smooth dimmer from 0 - 100 %

Motors

5 high quality stepping-motors controlled by microprocessors

Optical System

High luminous-efficiency parabolic system
All lenses are anti-reflection coated
Manually adjustable beam angle 8°-22°
150 mm fresnel lens

Fans

Two axial fans

Electronics

Built-in microphone for music trigger
Master/slave operation

3 freely programmable programs (99 steps each)

Digital serial input DMX-512

2 DMX channel-presettings (8 bit protocols):

Channel	Mode 1 (default)	Mode 2
1	Lamp On/Off, reset	Lamp On/Off, reset
2	No function	Cyan
3	Cyan	Magenta
4	Magenta	Yellow
5	Yellow	Speed of CMY
6	Speed of CMY	Colour macros
7	Colour macros	Effect-wheel
8	No function	Shutter, strobe
9	No function	Dimmer intensity
10	Shutter, strobe	
11	Dimmer intensity	

Rigging

Stands directly on the floor with removable stand
Mounts horizontally or vertically with mounting bracket
Vertical head adjusting range: 135°

Beampath

Temperatures

Maximum ambient temperature t_a : 40° C
Maximum housing temperature t_b : 75° C (steady state)

Minimum distances

Min.distance from flammable surfaces: 0,5 m
Min.distance to lighted object: 1,0 m

Weight

EU-version:13 kg **Shipping weight:** EU-version:17 kg
US-version:14,5 kg US-version:19 kg

Optional accessories

Barn-doors (black).....10i ĩ 0002
Barn-doors (grey).....10i ĩ 0004
Removable stand.....10i ĩ 0003

Dimensions (mm)

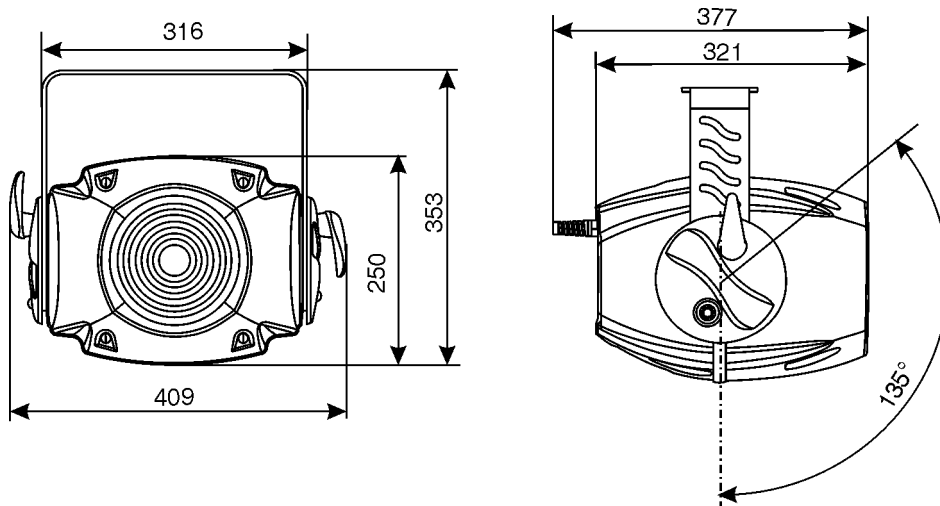

11. Maintenance and cleaning

The operator has to make sure that safety-relating and machine-technical installations are inspected by an expert after every four years in the course of an acceptance test.

The operator has to make sure that safety-relating and machine-technical installations are inspected by a skilled person once a year.

The following points have to be considered during the inspection:

- 1) All screws used for installing the devices or parts of the device have to be tightly connected and must not be corroded.
- 2) There must not be any deformations on housings, fixations and installation spots (ceiling, suspension, trussing).
- 3) Mechanically moved parts like axles, eyes and others must not show any traces of wearing (e.g. material abrading or damages) and must not rotate with unbalances.
- 4) The electric power supply cables must not show any damages, material fatigue (e.g. porous cables) or sediments. Further instructions depending on the installation spot and usage have to be adhered by a skilled installer and any safety problems have to be removed.

DANGER TO LIFE !

Disconnect from the mains before starting maintenance operation!

It is absolutely essential that the fixture is kept clean and that dust, dirt and smoke-fluid residues must not build up on or within the fixture. Otherwise, the fixture's light-output will be significantly reduced. Regular cleaning will not only ensure the maximum light-output, but will also allow the fixture to function reliably throughout its life.

Please use a moist, lint-free cloth. Never use alcohol or solvents!

The front fresnel lens will require weekly cleaning as smoke-fluid tends to building up residues, reducing the light-output very quickly. The cooling fans should be cleaned monthly.

The interior of the fixture should be cleaned at least annually using a vacuum-cleaner or an air-jet.

The dichroic colour-filters and the internal lenses should be cleaned monthly.

There are no serviceable parts inside the device except for the lamp and the fuse. Maintenance and service operations are only to be carried out by authorized dealers.

Please refer to the instructions under „Fitting/Exchanging the lamp“.

Replacing the fuse

If the lamp burns out, the fine-wire fuse of the device might fuse, too. Only replace the fuse by a fuse of same type and rating.

Before replacing the fuse, unplug mains lead.

Procedure:

Step 1: Unscrew the fuseholder on the rear panel with a fitting screwdriver from the housing (anti-clockwise).

Step 2: Remove the old fuse from the fuseholder.

Step 3: Install the new fuse in the fuseholder.

Step 4: Replace the fuseholder in the housing and fix it.

Should you need any spare parts, please use genuine parts.

If the power supply cable of this device will be damaged (cable firmly connected with the device), it has to be replaced by authorized dealers only in order to avoid hazards.

If the power supply cable of this device will be damaged (replaceable cable), it has to be replaced by a special power supply cable available at your dealer.

Should you have further questions, please contact your dealer.

Version 2. \$ (FI. €€2001)

12. Appendix 1 - Menu map

Default settings=Bold print

Menu Level 1	Menu Level 2	Menu Level 3	Menu Level 4	Menu Level 5	Menu Level 6	DESCRIPTION	
A001	dM.Ad.	A001-A502				DMX addresss	
	MA.SL.	d.Abl.				Disable master/slave	
		MASt.					Set fixture as a master
		SLA.1-SLA9				slave address	
SL.Ct.	SL.C.1-SL.C.9					Select slave for remote control	
InFo	Po.ti.	totl				Total hours of operation since fabricated	
		rSEt				Hours of operation since counter reset	
	La.ti.	totl				Total hours of lamp operation since fabricated	
		rSEt				Lamp hours since counter reset	
	LA.St.	totl				Total number of lamp strikes since fabricated	
		rSEt				Number of lamp strikes since counter reset	
	Hi.tE.	totl				Max.head temperature since fabricated [°C]	
		rSEt				Max.head temperature since counter reset °C	
	tEMP.					Current head temperature [°C]	
	dM.In.	Func.	0-255				View DMX Fans/lamp/reset value
		CYAn	0-255				View DMX cyan level value
		MAGE.	0-255				View DMX magenta level value
		YELL.	0-255				View DMX yellow level value
		C.SPd.	0-255				View DMX CMY/dimmer speed value
MACr.		0-255				View DMX macro value	
Stro.		0-255				View DMX strobe value	
dimr		0-255				View DMX dimmer position value	
VErS					Software version		
PErS	dM.Pr.	Mod.1				Set channels setting 1	
		Mod.2				Set channels setting 2	
	LA.Pr.	LA.Au.	On OFF				Lamp automatic.ON after switching fixture on No automatic lamp strikes
		d.L.OF.	On OFF				Enable lamp OFF via DMX command Disable lamp OFF via DMX command
		dM.On	On OFF				Lamp automatically ON if DMX is present Lamp will remain OFF if DMX is present
		dM.OF.	On OFF				Lamp automatically OFF if DMX is missing Lamp will remain ON if DMX is missing
		EN.Sn.	On OFF				Enable lamp light sensor Disable lamp light sensor
	diSp.	turn	<i>normal</i> <i>inverted</i>				Normal LED display LED display turned by 180°
		d.On	On OFF				Display permanent on Display turns off 2 min. after last key press
			d.Int.	20,40,60, 80, 100			
		Mi.SE.	1.. 10 ..20				Set microphone sensitivity
	FAnS	Auto					Cont. control of fans speed without DMX value
		HIGH					High(max.) speed of fans
		rEG					Continuous controlling of fans speed
LoOF						Low speed-switch off the lamp operating	
LoHI						Low speed-switch to high speed of the fans	
dF.SE.					Return all personality options to factory default.		

Menu Level 1	Menu Level 2	Menu Level 3	Menu Level 4	Menu Level 5	Menu Level 6	DESCRIPTION	
LAMP	On					Lamp power ON	
	OFF	A001-A500				Lamp power OFF	
tEst						Run demo	
St.Al.	Audi	On				Enable the sound control of the run. programs	
		OFF				Disable the sound control of the run. programs	
	Auto	OFF				No program runs after switching fixture on	
		tEst				Test program runs after switching fixture on	
		PrG.1				Program No.1 runs after switching fixture on	
		PrG.2				Program No.2 runs after switching fixture on	
	PLAy	PrG.3				Program No.3 runs after switching fixture on	
		tEst	run			Test runs in loop	
		PrG.1	run			Program No.1 runs in loop	
	Edit	PrG.1- PrG.3		MASt.- SLA.9 (only if Master is selected)	P.End	1-99	Set a total number of the program steps
					CYAn	0-255	Set DMX value for cyan
					MAGE.	0-255	Set DMX value for magenta
					YELL.	0-255	Set DMX value for yellow
					C.SPd.	0-255	Set DMX value for speed of CMY and dimmer.
					MACr.	0-255	Set DMX value for colour macros
					Stro.	0-255	Set DMX value for strobe
					dimr	0-255	Set DMX value for dimmer
S.tim					0,1-25,5	Set step time [sec.]	
COPY						Copying current prog.step to next step	
rESE						Run a reset	
SPEC		CYAn	CYA 0- CYA 5			Select presetting cyan flag position	
		MAGE.	MAG 0- MAG 5			Select presetting magenta flag position	
		YELL.	YEL 0- YEL 5			Select presetting yellow flag position	
		C.SPd	CSP 0- CSP 5			Select presetting CMY and dimmer speed	
		MACr.	OFF-MA 30			Select presetting colour macro	
		Stro.	OPEn, Str. 1-Str.9			Select presetting strobe position	
		dimr	dim.0- dimC			Select presetting dimmer position	
	LA.Ad.	dimr	0-255			Select dimmer intensity for lamp adjustment	
	Code					Fixture code	
	Adj.	Func.	0-255				Select DMX value for Func.of fans/lamp/reset
		CYAn	0-255				Select DMX value for cyan flag position
		MAGE.	0-255				Select DMX value for magenta flag position
		YELL.	0-255				Select DMX value for yellow flag position
MACr.		0-255				Select DMX value for colour macros	
Stro.		0-255				Select DMX value for strobe	
dimr	0-255				Select DMX value for dimmer position		

13. Appendix 2 - Changing the power supply settings

Both the transformer and the ballast must be connected correctly for the local AC voltage and frequency. The wrong settings can cause poor performance or damage of the moving head. The factory settings are printed next to the power switch.

If you want to change the power supply settings, follow the instructions:

1. Disconnect the fixture from AC power.
2. Remove the rear cover by loosening the 4 screws.
3. Move the wire ① on the transformer connection block to the position according to the desired voltage.
4. Move the wire ② on the ballast connection block to the position according to the desired frequency (voltage).
5. Put the cover back before applying AC power.

Examples:

EU-version

Power supply setting: 230 V / 50 Hz

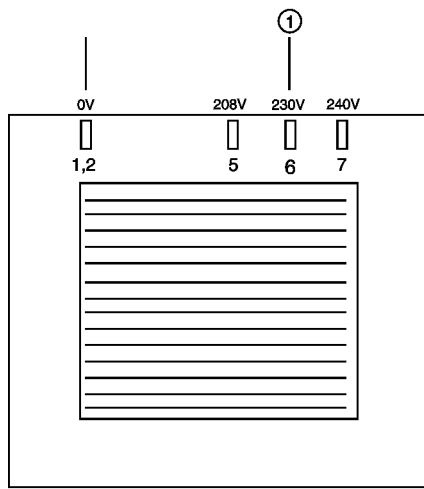

Transformer

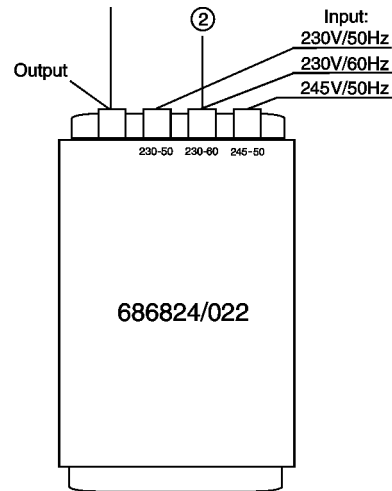

Ballast

US - version

Power supply setting: 120 V / 60 Hz

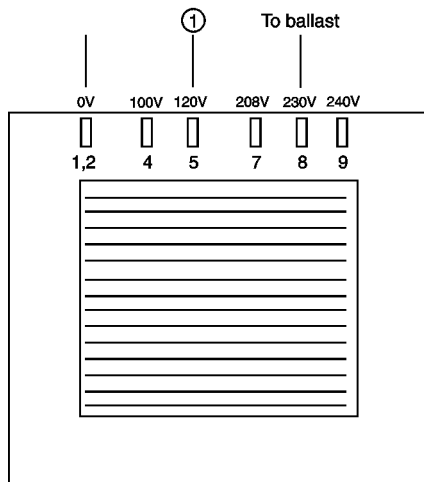

Transformer

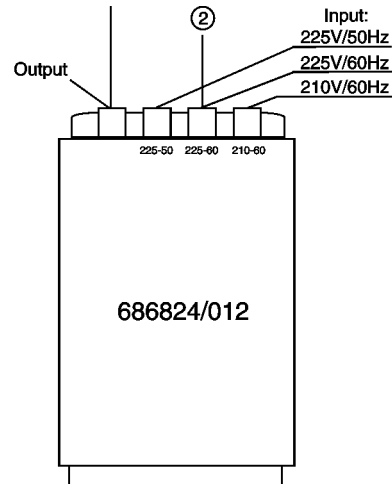

Ballast