

Jarag-5 / PAR20

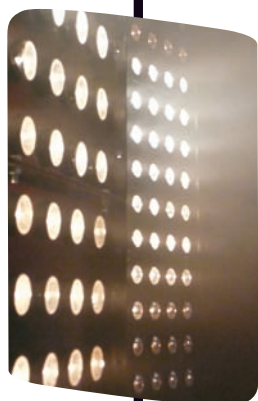

Subtle

Evolved

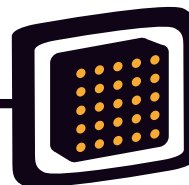

Powerful

Innovating



Overview

Enter the world of the halogen array

The JARAG combines conventional lighting systems and built-in electronics to create a new type of lighting system.

This modular, extendible system is made of units each with 25 individually controlled lamps. This fully integrated, reprogrammable multiple light source system is a simpler means of producing lighting effects. The controller is built into the unit for immediate use.

The JARAG uses standard halogen lamps to give a range of shades from amber to white with effects ranging from flash transitions to soft, slow variations.

It has never been so easy to set up lamp arrays. Combining several JARAG arrays will create walls of light displaying videos, patterns or animated text. No additional dimmers are required, just a direct supply and a DMX cable. Patterns and animations can be programmed into the system and videos can be sent from advanced DMX consoles.

The built-in sequencer can manage a whole unit using 31, 25 or only 6 channels. The JARAG is rated at more than 1800W and each of the 25 lamps is digitally controlled for lighting whose brightness and speed of transition can be set with precision and finesse.

Jarag-5 / PAR20

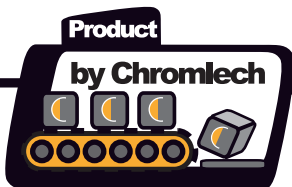
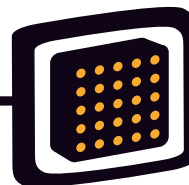

Technical drawing

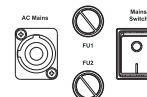
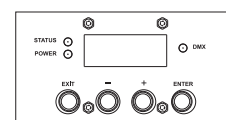
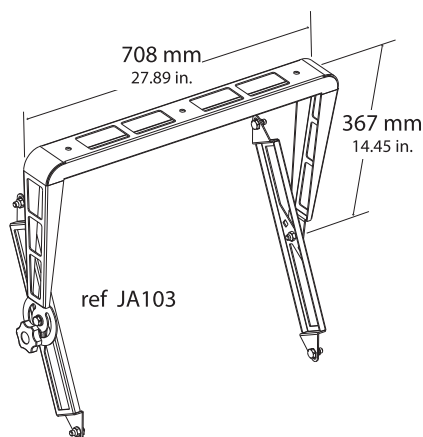
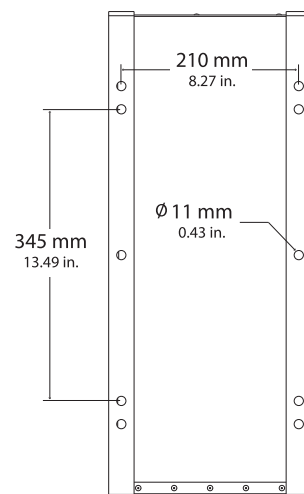
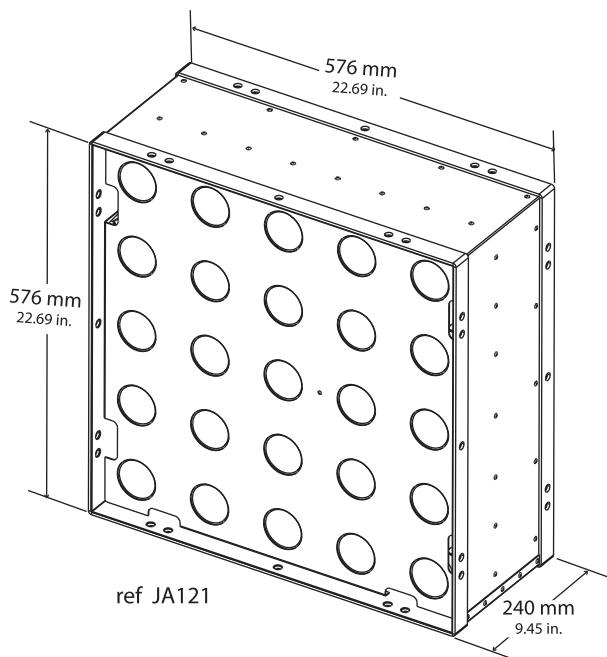

CHROMLECH
www.chromlech.com

Specifications

Power supply	Integrated dimmers, 230V / 50-60Hz / 8A / 1875 W
Lamps	25 lamps 230V, 75W, Hi-Spot ES63 type, 25°, 2800°K, 2500h, GU10, alu reflector
Frame	Aluminium frame, Black epoxy finish
Dimensions	58 x 58 x 24cm (HxWxD)
Weight	8,6 Kg (without lamps) - 10,5 Kg (with lamps) - Yoke : 4,3 Kg
Rigging	With adjustable yoke and/or frame's rigging point.
Assembly	JARAG can be juxtaposed and assembled together while preserving a constant lamp's grid spacing
Connectors	Powercon 20A, DMX in (XLR5), DMX out (XLR5), liaison RS232-C (SUBD9)
Control	DMX : 6, 25, or 6+25 channels The integrated sequencer is controled through 6 DMX channels (intensity, speed, effects/fade, rotation/symmetry, sequence selection), and manages up to 256 sequences of 32 steps. 128 sequences are factory programmed, 128 others sequences are available for user.

CHROMLECH

19, avenue Gabriel Fauré - 35235 Thorigné-Fouillard - France
Tel : +33 (0) 223 207 767 - Fax : +33 (0) 223 207 571
e-mail : contact@chromlech.com - Web : www.chromlech.com